

Synthesis of the Robust Regulators on the Basis of the Criterion of the Maximum Stability Degree

S. A. Gayvoronsky, T. A. Ezangina

Abstract—The robust control system objects with interval-undermined parameters is considered in this paper. Initial information about the system is its characteristic polynomial with interval coefficients. On the basis of coefficient estimations of quality indices and criterion of the maximum stability degree, the methods of synthesis of a robust regulator parametric is developed. The example of the robust stabilization system synthesis of the rope tension is given in this article.

Keywords—An interval polynomial, controller synthesis, analysis of quality factors, maximum degree of stability, robust degree of stability, robust oscillation, system accuracy.

I. INTRODUCTION

THE analysis of the synthesis methods of the automatic control systems (SAC) shows that it is desirable to have simple dependencies allowing moving very easily from quality indices of an SAC to the desired regulator parameters in order to choose the regulator tunings. Except a number of cases (for the low order systems) the dependencies are very difficult to obtain if the frequency or time quality factors are used. It is significantly easier to solve the problem concerning the parametric synthesis of a regulator on the basis of the root approach or by means of coefficient methods. These methods use the coefficients of a characteristic polynomial of a closed – loop SAC. A basis for this conclusion is in the following: on the one hand, the specified parameters are directly related to the physical parameters of SAC on the other hand, the arrangement of the roots of the characteristic polynomial depends on these coefficients. The arrangement of the roots of the characteristic polynomial defines such dynamic characteristics as oscillation and operation speed. This circumstance is one of the reasons that attract attention to the coefficient methods of stability and quality estimation of an SAC. These methods allow obtaining approximate, but simple ratios, binding (usually by some inequalities) the quality indices of an automatic control system and the desired regulator parameters [1]. One of the most widely used criteria of an automatic control system is the degree of system stability. It is known, that the automatic control systems synthesized by means of this criterion under other conditions being equal possess much higher operation speed, less overshoot, and higher stability factor [2]. The works [3]-[9] are devoted to the synthesis of the linear regulators ensuring

maximum stability degree in the stationary automatic control systems. Since practically all real SAC have unstable parameters that change within certain intervals the problem solution concerning the maximization of stability degree of these SAC is of great importance. It is suggested to use the coefficient method to solve this problem and develop the methodology of selection of the linear regulator parameters on the basis of this method. Oscillation limitation of the interval system by accepted value is an additional requirement by the synthesis of the automatic control system possessing the maximum stability degree.

II. THE CONDITIONS OF MAXIMIZATION OF THE INTERVAL SYSTEM STABILITY DEGREE

The characteristic polynomial of the closed SAC in the case of the interval uncertainty is of the following kind:

$$D(s, \bar{k}) = [d_n](\bar{k})s^n + [d_{n-1}](\bar{k})s^{n-1} + \dots + [d_0](\bar{k})s \quad (1)$$

where \bar{k} – is the vector of the adjustable parameters of the regulator,

$$\underline{d}_i(\bar{k}) \leq d_i(\bar{k}) \leq \overline{d}_i(\bar{k}), \quad i = \overline{0, n}.$$

It is obvious, that by the design of an automatic control system it is important not only to obtain a stable system but also ensure some certain performance quality. Let us formulate the sufficient stability conditions of the interval system on the basis of the coefficients of the characteristic polynomial.

Statement 1. In order the roots of the interval polynomial to be more left-handed from the vertical line that passes through the point $(-\eta, j0)$, $0 \leq \eta < \infty$ it is enough to determine the controller settings, where the following conditions are satisfied:

$$\begin{cases} \lambda_i \leq 0.465, \quad i = \overline{1, n-2}; \\ \underline{d}_m(\bar{k}) - \overline{d}_{m+1}(\bar{k})(n-i-1)\eta \geq 0, \quad m = \overline{1, n-1} \geq 0, \quad m = \overline{0, n-1}; \\ \underline{d}_0(\bar{k}) - \overline{d}_1(\bar{k})\eta + 2\overline{d}_2(\bar{k})\frac{\eta^2}{3} \geq 0. \end{cases} \quad (2)$$

*The reported study was partially supported by RFBR, research project No 13-01-98009.

S. A. Gayvoronsky and T.A. Ezangina are with the National Research Tomsk Polytechnic University, Russia (e-mail: eza-tanya@yandex.ru).

$$\lambda_i(\bar{k}, \eta) = \frac{\overline{d}_{i-1}(\bar{k}) \overline{d}_{i+2}(\bar{k})}{\left(\underline{d}_i(\bar{k}) - \overline{d}_{i+1}(\bar{k})(n-i-1)\eta\right) \left(\overline{d}_{i+1}(\bar{k}) - \overline{d}_{i+2}(\bar{k})(n-i-2)\eta\right)} \leq 0.465$$

– stability coefficients, The notion $\overline{d_{i+1}}$ means that coefficient d_{i+1} should be taken either as the maximum and minimum.

Proof. To evaluate the stability of the interval systems of an automatic control it is desirable to define its worst qualities, namely the maximum value of its stability coefficients $\lambda_i(\bar{k}, \eta)$

$$\lambda_i(\bar{k}, \eta) \rightarrow \max \quad (3)$$

Let us introduce the symbols: $d_{i-1}(\bar{k})d_{i+2}(\bar{k}) = r$,
 $(d_i(\bar{k}) - d_{i+1}(\bar{k})(n-i-1)\eta)(d_{i+1}(\bar{k}) - d_{i+2}(\bar{k})(n-i-2)\eta) = l$.
 It is obvious, that the problem situation (3) is fulfilled, if

$$r \rightarrow \max, l \rightarrow \min \quad (4)$$

On the basis of the interval analysis it is possible to make a conclusion, that the problem situation (4) is fulfilled, if

$$r = \overline{d_{i-1}(\bar{k})} \overline{d_{i+2}(\bar{k})}$$

and

$$l = (\overline{d_i(\bar{k})} - \overline{d_{i+1}(\bar{k})}(n-i-1)\eta)(\overline{d_{i+1}(\bar{k})} - \overline{d_{i+2}(\bar{k})}(n-i-2)\eta)$$

It is obvious, if the problem situations (3) are fulfilled for the given limits of the interval coefficients, they are also fulfilled for the other values from the specified intervals.

To determine the maximum robust degree of stability on basis of the statement 6 the following statement is formulated.

Statement 2. To determine the maximum robust degree of stability of the interval automatic control system it is necessary for all combinations of interval coefficients to provide the maximum value in the (n-2) systems by the selection of controller parameters:

$$\begin{cases} \lambda_i(\bar{k}, \eta) = 0,465, i = \overline{1, n-2}; \\ \lambda_j(\bar{k}, \eta) \leq 0,465, j = \overline{1, n-2}, j \neq i; \\ \overline{d_m(\bar{k})} - \overline{d_{m+1}(\bar{k})}(n-i-1)\eta \geq 0, m = \overline{1, n-1}, m = \overline{0, n-1}; \\ \overline{d_0(\bar{k})} - \overline{d_1(\bar{k})}\eta + 2\overline{d_2(\bar{k})}\frac{\eta^2}{3} \geq 0. \end{cases} \quad (5)$$

Proof. It is obvious, if the increase the value of η in the system (5) changing the parameters of the controller can be as long as $\lambda_i(\bar{k}, \eta) < 0,465, \forall i = \overline{1, n-2}$. At $\lambda_i(\bar{k}, \eta) = 0,465$ we obtain the maximum value of the index of stability corresponding to the maximum degree of stability of the system. At the intervals coefficients of the polynomial are chosen under statement 1.

III. THE CONDITIONS OF THE INTERVAL SYSTEM OSCILLATION LIMIT

Let us formulate the sufficient condition for the given robust oscillation of the interval system.

Statement 3. The roots of the interval characteristic polynomial to be in the specified angular domain there is necessary to apply such controller settings, where the next conditions are satisfied:

$$\delta_i(\bar{k}) = \overline{d_i^2(\bar{k})} / \overline{d_{i-1}(\bar{k})} \overline{d_{i+1}(\bar{k})} > \delta_d, i = \overline{1, n-1}, \quad (6)$$

where δ_i - is the oscillation indices, δ_d - is the acceptable oscillation indices. Connection δ_d and sectors of roots location are determined on basis of Fig. 1.

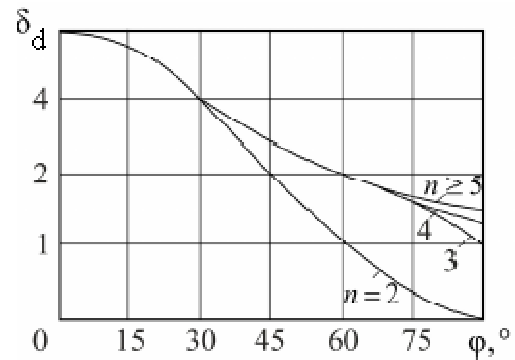

Fig. 1 Dependence of the sector of roots location on the value δ_d

Proof. To evaluate the stability of the interval systems of an automatic control it is desirable to define its worst qualities, namely the minimum value of its oscillation coefficients $\delta_i(\bar{k})$

$$\delta_i(\bar{k}, \eta) \rightarrow \min \quad (7)$$

Let us introduce the symbols: $d_i(\bar{k})^2 = r, d_{i+1}d_{i-1}(\bar{k}) = l$. It is obvious, that the problem situation (7) is fulfilled, if

$$r \rightarrow \min, l \rightarrow \max \quad (8)$$

On the basis of the interval analysis it is possible to make a conclusion, that the problem situation (8) is fulfilled, if $r = \overline{d_i(\bar{k})^2}$ and $l = \overline{d_{i+1}(\bar{k})} \overline{d_{i-1}(\bar{k})}$. It is obvious, if the problem situations (7) are fulfilled for the given limits of the interval coefficients, they are also fulfilled for the other values from the specified intervals.

IV. ALGORITHM OF A ROBUST CONTROLLER SYNTHESIS

For parametric synthesis of linear controllers of an interval automatic control system the algorithm is developed. It consists of the following stages:

- 1) The acquisition of the initial conditions: the limits of the interval coefficients of a transfer function of a control object, the permissible value of oscillation coefficients.
- 2) The definition of intervals of characteristic polynomial coefficients of a closed loop interval automatic control system.
- 3) The definition of expression for one parameter on the basis of the sufficient condition of the specified robust oscillation (6).
- 4) The acquisition of sufficient conditions of maximum robust degree of stability (5) and the expression of the second parameter of a controller through the degree of stability.
- 5) The generation of an inequality system to find maximum robust degree of stability.
- 6) The solution of an inequality system and the definition of the maximum degree of stability.
- 7) The repetition of P. 4, 5 for other and other limits relations of the interval coefficients.
- 8) The choice of and the definition of the desired maximum robust degree of stability and robust controller settings.

Block diagram of this algorithm is presented in Fig. 2.

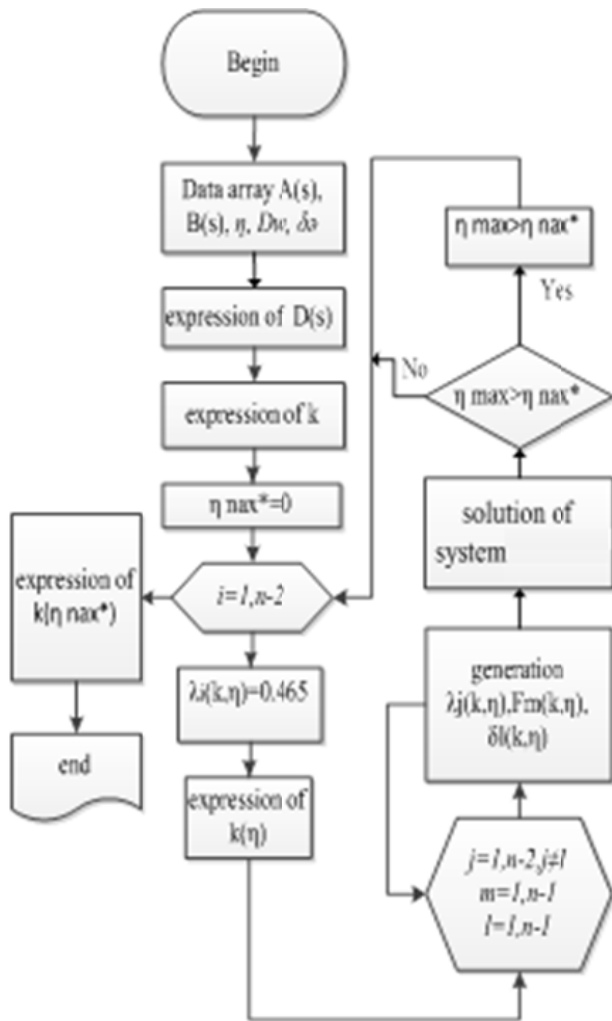

Fig. 2 Algorithm of a robust controller synthesis

V. THE SYNTHESIS OF THE ROBUST PI-REGULATORS OF THE STABILIZATION SYSTEM OF THE ROPE TENSION

The stabilization system of the rope tension (SSRT) [10] for the bench of zero-gravity imitation is chosen as an example of the synthesis. The robust regulator should stabilize the tension in the rope where the section of the dry spacecraft under the conditions of parameter instability is hung out.

The functional diagram of SSRT consisting of a mechanical system (MS), a tension sensor (TS), a thyristor converter (TC), a motor (M), a drive unit (DU) and a regulator (R) is shown in Fig. 3.

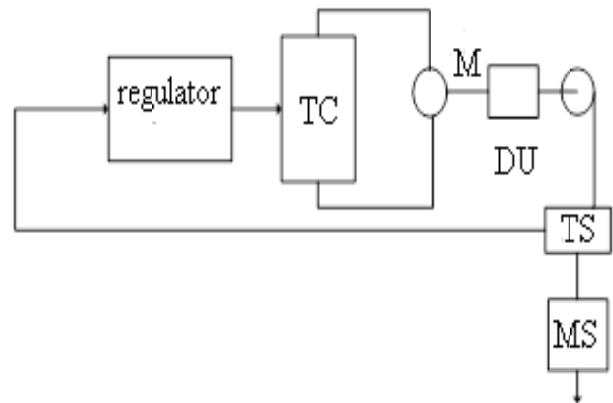

Fig. 3 Functional diagram of SSRT

The mathematical model of the system in the form of the block diagram is made up on the basis of the differential equations of certain elements of SSRT. This block diagram is illustrated in Fig. 4.

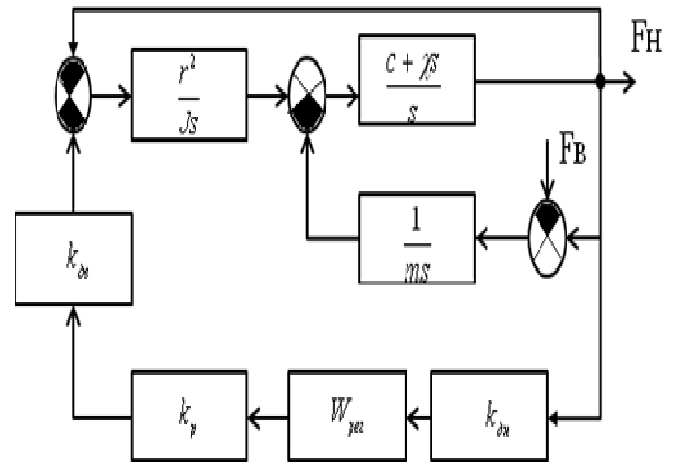

Fig. 4 Block diagram of SSRT

The following symbols are used in Fig. 4.: $J = 0.5$ kg - moment of inertia of an electric drive stabilization system of rope tension (SSRT); $C = C_{y0} / l$ N/m - rope rigidity; $\chi = \chi_{y0} / l$ (Ns)/m - is the damping coefficient of oscillations in the rope; $C_{y0} = 2000$ N - is the specific stiffness of the

rope; $\chi_{yo} = 1000$ (Ns) – is the specific damping coefficient; $r = 0.05$ m – is the radius of the drive pulley of an electric drive.

The parameters l – the rope length and m – the mass of the spacecraft section are considered as the interval parameters of SSRT. The input signal of the SSRT is external influence force (F_n), leading member of the spacecraft to move in zero – gravity. The output of the SSRT is the rope tension force F_n .

PI-regulator is chose as a regulator and its transfer function is of the following form: $W_p(s) = \frac{k_1 + k_2 s}{s}$. The given regulator has two generic parameters: k_1, k_2 , that define the quality of the transient processes in SSRT.

As a result of the block diagram conversion, represented in Fig. 4 the characteristic polynomial of the system is obtained:

$$D(s) = [d_3]s^3 + [d_2]s^2 + [d_1]s^1 + [d_0],$$

where

$$\begin{aligned} d_3 &= [0.5; 2.5], \\ d_2 &= [12.5; 15] + 2.50k_2, \\ d_1 &= [25; 30] + 5k_2 + 2.5k_1, \\ d_0 &= 5k_1. \end{aligned}$$

Let us work out the system of conditional maximum stability degree by the oscillation limits for the SSRT under consideration on the basis of the formulas (5), (6).

$$\begin{cases} \frac{12.5k_1}{((25 + 5k_2 + 2.5k_1) - (15 + 2.5k_2)\eta)(15 + 2.5k_2)} = 0,465; \\ (25 + 5k_2 + 2.5k_1) - (15 + 2.5k_2)\eta \geq 0; \\ 5k_1 - (30 + 5k_2 + 2.5k_1)\eta + (12.5 + 2.5k_2)\frac{\eta^2}{3} \geq 0; \\ \frac{(25 + 5k_2 + 2.5k_1)^2}{5k_1(15 + 2.5k_2)} \geq \delta_d; \\ \frac{(12.5 + 2.5k_2)^2}{2.5(30 + 5k_2 + 2.5k_1)} = \delta_d. \end{cases} \quad (9)$$

δ_d is equal to 1,7 ($\delta_d = 1,7$) in the last expression in the system (9). This corresponds to the sector of polynomial roots location $\varphi = \pm 70^\circ$. Let us express the regulator k_1 parameter through

$$k_2 : k_1(k_2) = \frac{(28,75 + 41,25k_2 + 6,25)}{10,6}.$$

Then, the equation

$$\overline{d_0}(k_1(k_2)) \overline{d_3} - 0.465(\overline{d_1}(k_1(k_2), k_2) - \eta \overline{d_2}(k_1(k_2), k_2))(\overline{d_2}(k_1(k_2), k_2))) = 0,$$

is obtained from the first equation of the system (9). Let us express the second regulator parameter through the stability degree η . Carrying out the mentioned above mathematical manipulation the inequality system (10) is obtained.

$$\begin{cases} (25 + 5k_2(\eta) + 2.5k_1(k_2(\eta))) - (15 + 2.5k_2(\eta))\eta \geq 0; \\ 5k_1(k_2(\eta)) - (30 + 5k_2(\eta) + 2.5k_1(k_2(\eta)))\eta + (12.5 + 2.5k_2(k_1(\eta)))\frac{\eta^2}{3} \geq 0; \\ \frac{(25 + 5k_2(\eta) + 2.5k_1(k_2(\eta)))^2}{5k_1(k_2(\eta))(15 + 2.5k_2(\eta))} \geq 1.7. \end{cases} \quad (10)$$

System solving (5) is convenient to obtain using the graphical method (Fig. 5).

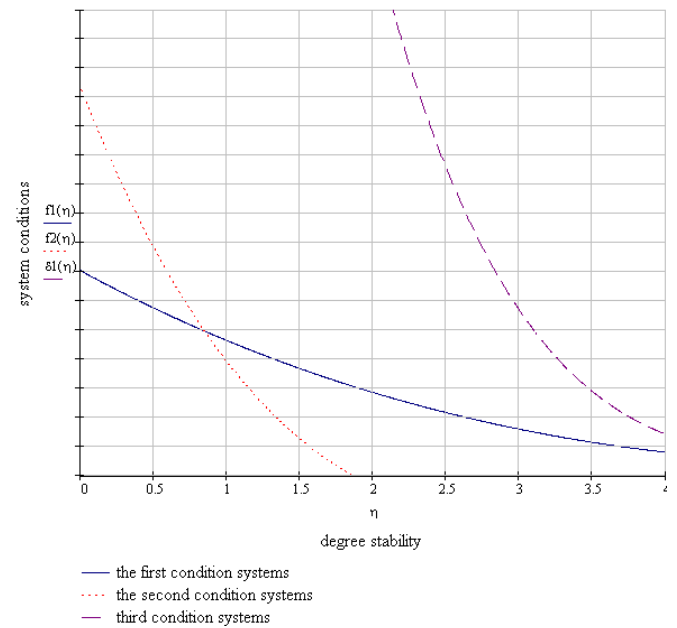

Fig. 5 Graphical system solving (10)

Let us define the worst possible stability degree $\eta_{max} = 1.987$ for the SSRT from the figure. The worst possible stability degree is provided by PI-regulator. Putting the computed value η_{max} in the equation for the regulator parameters $k_1 = 5,71; k_2 = 0,37$ are found.

To estimate the robust quality of SSRT by means of the root method the localization areas of the roots of the interval characteristic polynomial are built (Fig. 6).

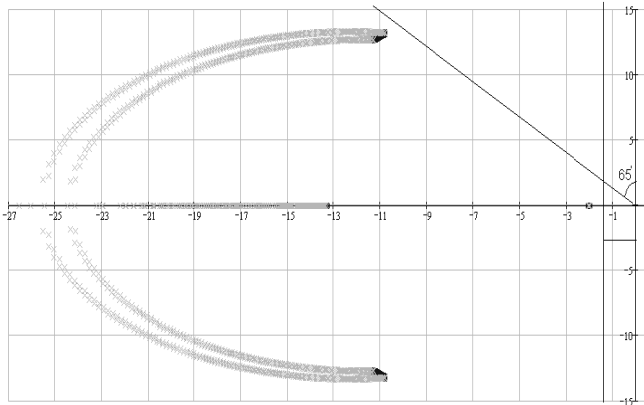
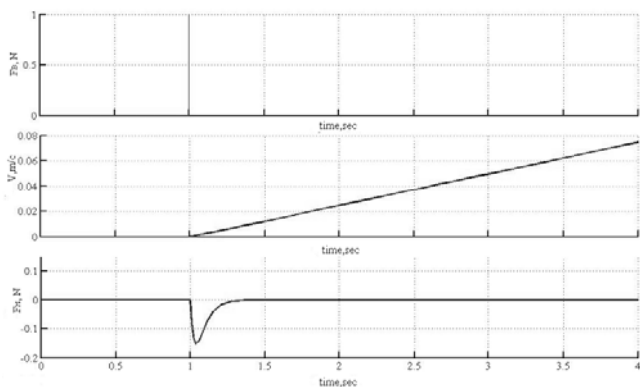

Fig. 6 The areas of roots localization

As it is seen from Fig. 6 SSRT has maximum robust stability degree $\eta_{\max} = 2,0$ and robust oscillation $\varphi = \pm 65^\circ$. The difference of the real estimations of the robust quality from the calculated one can be explained by the sufficiency of conditions used by regulator synthesis.

VI. SIMULATION OF CONTROL PROCESSES

To check and test the functionality of the robust SSRT with a synthesized regulator its simulation is carried out in software Matlab with the application of Simulink. The system simulation is done in the vertex V of polyhedron of its interval parameters that correspond to maximum robust stability degree. By building of the areas of the roots localization of the interval characteristic polynomial (see Fig. 6) it was determined that the given vertex has the coordinates V(40;1), where the first coordinate corresponds to section mass, and the second one to the rope length. The simulation in the vertex V is done for two typical modes of operation of SSRT corresponding to outside step and impulse excitation F_B (Fig. 7)



(a)

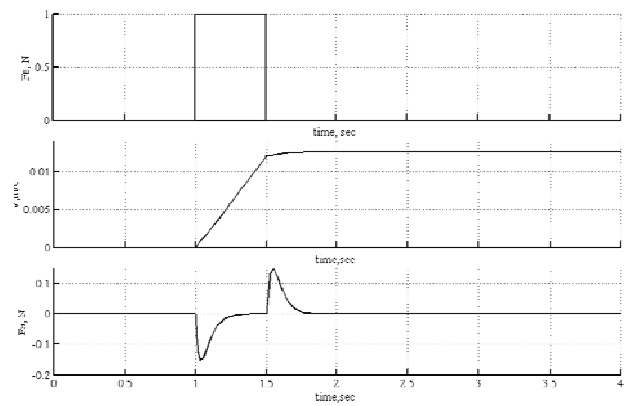

(b)

Fig. 7 Transient processes in SSRT by (a) step F_B , (b) impulse F_B

Upon the analysis of Fig. 7 the following conclusion can be made. When the section of the spacecraft is under the step excitation the section of this spacecraft has a uniformly accelerated motion. Due to astaticism in SSRT the steady-state value is equal to zero. Under influence of impulse action, the section of the spacecraft moves with constant linear speed. The steady-state value is also equal to zero. The mentioned motion manner of the spacecraft in both modes of operation corresponds to the zero-gravity conditions.

VII. CONCLUSION

The algorithm of the synthesis of the robust regulators developed by the authors is presented in the given paper. The coefficient method and the criterion of the maximum operation speed are applied to calculate the parameters of the used in the system PI-regulator. Besides, the numerical example of the synthesis of the robust stabilization system of the rope tension is given, that allows to create zero-gravity conditions by the testing of a spaceship on a special laboratory bench. The efficiency of the system operation is verified by the diagrams of the transient processes under different operation conditions.

The carried out research revealed a number of new problems, which solution allows improving the operation quality of the robust stabilization system of the rope tension used for the laboratory bench which imitates zero gravity. It is reasonable to take into account different concomitant characters (dry friction in the rope- building block system, backlash of the electric drive) of non-linearity by the system design and simulation.

REFERENCES

- [1] B. N Petrov, N. I Sokolov, A.V Lipatov and other objects. Automatic control systems with variable parameters: Engineering methods of analysis and synthesis. M.: Mechanical Engineering, 1986, p. 256.
- [2] S.A. Gayvoronskiy, T.A Ezangina. Software for the synthesis of linear regulators systems with interval parameters. Nevs TPU, ser. Control, Computing and Informatics, 2012, Vol.321, № 5, pp.29-34.
- [3] L.H. Keel. *Robust stability and performance with fixed-order controllers*. Automatica, 1999, №. 35, pp. 1717-1724.

- [4] L. Wang. *Robust strong stabilizability of interval plants: it suffices to check two t vertices*. System and control letters, 1995, №. 26. pp. 133-136.
- [5] A.N. Volkov, Y. V. Zagashvili. *The method of synthesis of automatic control systems with maximum stability under constraints*. Izvestiya RAS. Ser. Computer and Systems, 1997, №. 3, pp. 12-19.
- [6] D.P. Kim *Synthesis regulator maximum degree of stability*. Drive Technology, 2003, №. 4, pp.52-57.
- [7] A.V Tatarinov, A.M Tsirlin. *Mathematical programming problems containing complex variables, and the maximum degree of stability of linear dynamical systems*. Bulletin RAS. Ser. Computer and Systems, 1995, №. 1, pp. 28-33.
- [8] Rimsky, G.V. Root locus methods for robust control systems quality and stability investigations / Rimsky G.V., Nesenчук A.A. // Proceedings IFAC 13th Triennial World Congress. – San Francisco, USA, 1996. – P. 469-474.
- [9] Rao, P. Robust tuning of power system stabilizers using QFT / Rao P., Sen I. // IEEE transactions on control systems technology, 1999, Vol. 7, N. 4. – P. 478- 486.
- [10] Vadutov OS, Melnikov YS, Gayvoronskiy SA, Novokshonov S. *Synthesis of dynamic controls the interval of automatic systems stand simulate weightlessness* // Information Systems and Technology. Report of the International Conference Novosibirsk, 2000.-p.371-377