

# Design and Analysis of Two-Phase Boost DC-DC Converter

Taufik Taufik, Tadeus Gunawan, Dale Dolan and Makbul Anwari

**Abstract**—Multiphasing of dc-dc converters has been known to give technical and economical benefits to low voltage high power buck regulator modules. A major advantage of multiphasing dc-dc converters is the improvement of input and output performances in the buck converter. From this aspect, a potential use would be in renewable energy where power quality plays an important factor. This paper presents the design of a 2-phase 200W boost converter for battery charging application. Analysis of results from hardware measurement of the boost converter demonstrates the benefits of using multiphase. Results from the hardware prototype of the 2-phase boost converter further show the potential extension of multiphase beyond its commonly used low voltage high current domains.

**Keywords**—Multiphase, boost converter, power electronics.

## I. INTRODUCTION

THE prediction that Gordon L. Moore made in a 1965 paper, or known today as Moore's Law, that the number of transistor on a chip will double every 18 months is one that has continued to agree with the historical data [1]. Since it is not a physical law, it does not have to continue on this trend forever. One possible deviation from the historical trend of the number of transistor per-chip is the ever so difficult task of powering these microprocessors [1]. For example, the average power per transistor for a Pentium chip today is approximately  $1.3\mu\text{W}$ . This small amount of power becomes a relatively large problem because the number of transistor on a chip has already surpassed 1 billion. The current power requirements are around 200 watts for a single microprocessor for past and future power requirements of microprocessors [2]. The increasing power requirements, however, do not tell the whole story. In order to understand the real challenge we have to look at the current and voltage requirements as well. In order to reduce power consumption of transistors, a lower voltage is needed. The voltage is currently on the order of 1V. Taking into account the increasing power requirements for future microprocessors with the reduction in voltage ( $V_{cc}$ ), the

current must therefore increase. For high performance CPUs, currents are presently upwards of 230A increasing into the range of 270A in 2010 [2].

The solution to this problem is solved by a creative use of buck converters that are placed in parallel with their control signals offset by a phase angle, or commonly known today as a multiphase Voltage Regulator Module (VRM). A voltage regulator module (VRM) is a dc-dc converter that provides the necessary power into a microprocessor. Design specifications of VRMs are typically determined by microprocessor's manufacturers. For example, Intel has established design guidelines for VRM called Intel VRM11.0 [3]. Today's VRMs are based on a topology called the multiphase synchronous buck converter as shown in Figure 1 [4,5,6,7,8].

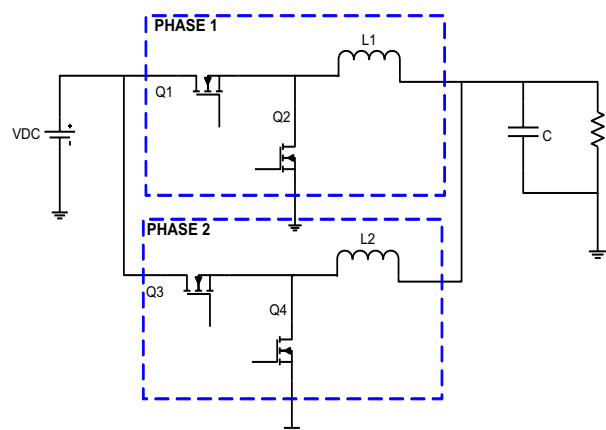

Fig. 1 Multiphase synchronous buck topology.

Despite the extensive use of multiphase in buck topology, the advantages that multiphase have to offer have been investigated to include other topologies such as reported in [9,10]. One major benefit of multiphase is the improvement of input and output characteristics due to frequency multiplication produced by the multiphasing of input and output current. This in turn produces smaller input and output filtering requirements as well as faster transient performance compared to the non-multiphase counterpart per given output power. One application that would greatly benefit from these benefits is dc-dc converters used in renewable energy. In particular, those converters used to charge batteries from a dc source. In some cases, the converter is required to step up the voltage from the source to the battery voltage; hence the need to use a Boost converter. In this paper, the design of a 2-phase 200W boost converter will be presented to exhibit the benefits

Taufik is with the Electrical Engineering Department, California Polytechnic State University, San Luis Obispo, CA 93407, USA (Phone: 805-756-2318; fax: 805-756-2318; e-mail: taufik@calpoly.edu).

Tadeus Gunawan is with the Electrical Engineering Department, California Polytechnic State University, San Luis Obispo, CA 93407, USA (e-mail: rprasety@calpoly.edu)

Dale Dolan is with the Electrical Engineering Department, California Polytechnic State University, San Luis Obispo, CA 93407, USA (e-mail: dsdolan@calpoly.edu)

Makbul Anwari is with the Department of Electrical Engineering, Makkah, Saudi Arabia (e-mail: makbul@ieec.org).

and hence the potential use of multiphase scheme beyond the buck topology.

## II. TWO-PHASE BOOST CONVERTER

Figure 2 shows the basic 2-phase boost converter. One advantage that is evident from the figure is that the multiphase configuration allows the combination of output capacitor from each individual boost into just a single capacitor  $C_o$ . Due to the frequency multiplication property of the multiphase, the output voltage will actually have ripple component twice the operating switching frequency of each individual boost converter. This may further reduce the output filtering requirement. The frequency multiplication effect also occurs at the input side of the boost and hence reducing the input filtering requirement as well as improving the quality of the input current. In turns, both input and output sides of the multiphase boost will emit less  $dv/dt$  and  $di/dt$  noises back to the system connected to them.

Figure 3 illustrates the timing signals for the two phases (switches Q1 and Q2). The frequency multiplication effect is clearly shown on the combined  $I_{in}$  waveform as having its period half that of individual inductor current. One advantage that is not apparent from the Figure is the amount of peak to peak ripple on the input current which should be half that of each individual inductor current. This is called the ripple cancellation effect in multiphase scheme.

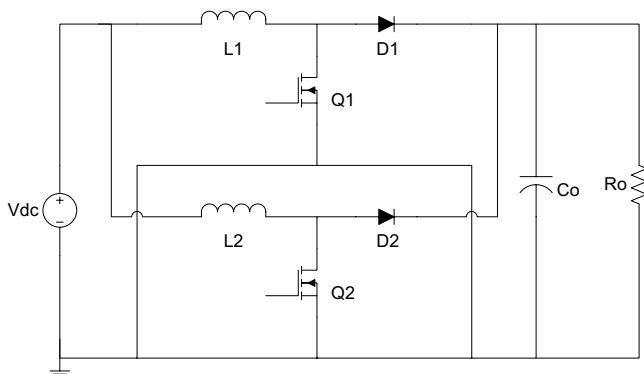

Fig. 2 Multiphase boost topology

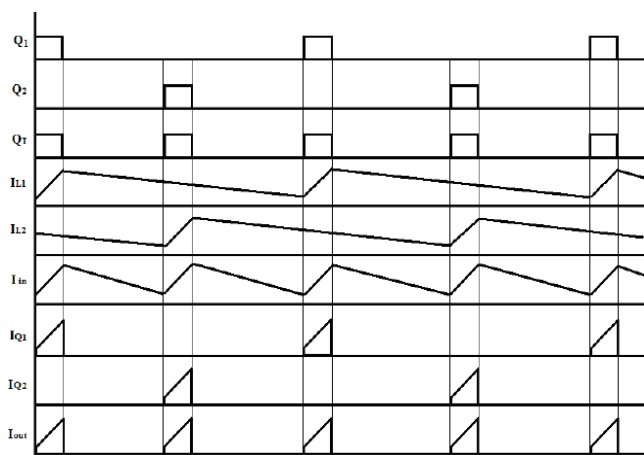

Fig. 3 Timing signals for switches Q1 and Q2, the resulting inductor current and input current, and switch currents

## III. SIMULATION RESULTS

The Two-Phase Boost Converter was designed to meet certain design parameters as listed in Table I. Since many boost converters are being used in renewable energy applications to step up battery output voltage, the converter will be designed to have input and output voltages at the level that would be achievable or usable by battery. The 200W output power was chosen to match with available power rating of PV panels. To ensure reliable and good quality output, the proposed two-phase converter should have output voltage peak-to-peak ripple and load regulation of less than 1%. In addition, to account for variation at the input voltage, the proposed converter should be able to maintain line regulation within 1%. Table I summarizes the design requirements for the 2-phase boost converter.

TABLE I. DESIGN REQUIREMENTS FOR THE CONVERTER

Parameters	Requirements
Rated Power	200 Watts
Input Voltage	36 V <sub>DC</sub>
Output Voltage	48 V <sub>DC</sub>
Input Current Max	5.56 Amps
Output Current Max	4.167 Amps
Operating Frequency	500 KHz
Line Regulation	< 1%
Load Regulation	< 1%
Output Voltage Ripple	< 1% V <sub>P-P</sub>
Efficiency	> 90%

Based on these design requirements, each component in the proposed was selected. A multiphase controller LT3782 from Linear Technology was chosen to provide the control signals for the two main switches in the 2-phase boost converter. Before a hardware prototype was built, the 2-phase boost was first simulated to ensure its operation. The software used for the simulation is Linear's LTSpice. The schematic of the 2-phase boost is depicted in Figure 4 showing all the selected components.

Table II summarizes the results from the computer simulation. As shown the efficiency at full load is slightly above 97%. From the table the line and load regulations are calculated to be 0.0167% and 0.044% respectively. The peak to peak inductor current ripple each was measured to be 0.85A. This relatively small ripple will be advantageous mainly in suppressing rms loss at main components such as the inductors themselves and the switches (MOSFETs). Figure 5 illustrates the final circuit board of the 2-phase boost converter showing the top layer and bottom layer.

TABLE II. SIMULATION RESULTS

Load [%]	R <sub>Load</sub> [Ω]	V <sub>out</sub> [V]	i <sub>out</sub> [A]	V <sub>in</sub> [V]	i <sub>in</sub> [A]	P <sub>out</sub> [W]	P <sub>in</sub> [W]	Efficiency [%]
10%	120	47.985	0.399	36	0.5563	19.188	21.836	95.81
20%	60	47.98	0.7997	36	1.1546	38.369	41.564	92.31
30%	40	47.98	1.1995	36	1.6908	57.551	60.87	94.55
40%	30	47.985	1.5995	36	2.2589	76.752	81.319	94.38
50%	24	47.974	1.9989	36	2.7876	95.896	100.35	95.56
60%	20	47.976	2.3988	36	3.3185	115.09	119.47	96.33
70%	17.14	47.974	2.799	36	3.8704	134.28	139.33	96.38
80%	15	47.971	3.1981	36	4.417	153.41	158.93	96.53
90%	13.3	47.975	3.599	36	4.9597	172.66	178.55	96.70
100%	12	47.964	3.997	36	5.4894	191.71	197.62	97.01

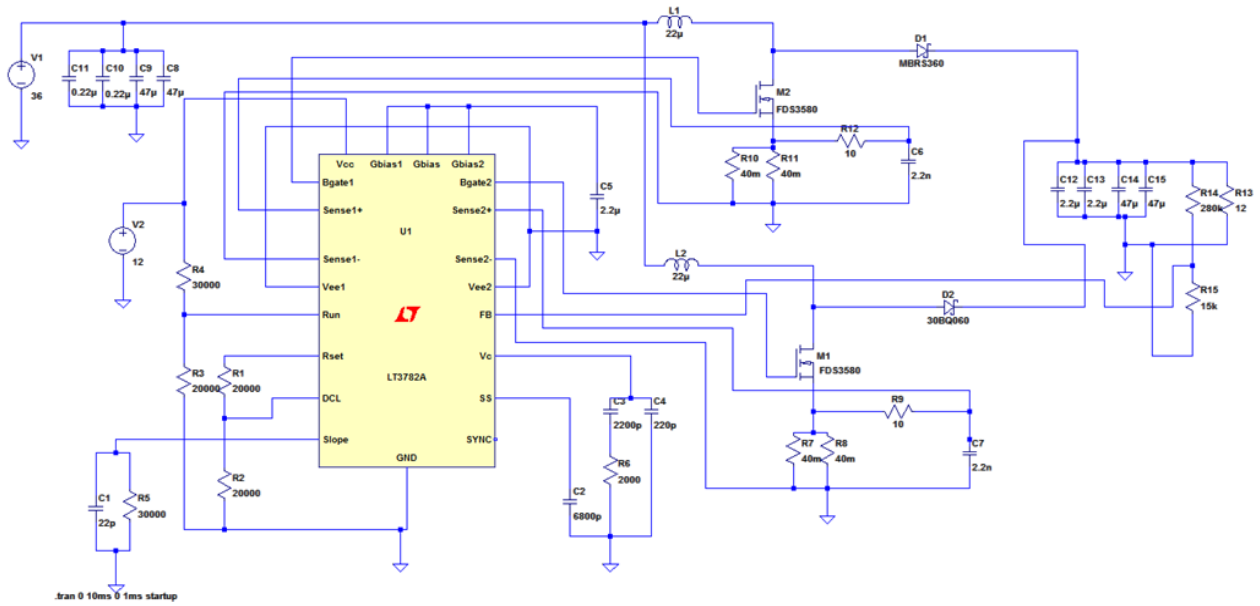

Fig. 4 LTSpiceIV schematic of the 2-phase boost converter

Figure 5 is a snapshot of the output voltage ripple during steady state. It ripples between 48.001Volts and 47.994V with an average value of 47.964V, approximately 99.9% of the required value of 48V. Using the same values, the output voltage ripple is calculated to be 0.007VP-P or 0.015% which is well below the required 1% ripple. Secondly it is important to check the output voltage frequency. The required operating frequency of each phase is 500 kHz, thus creating an expected output frequency of 1MHz due to frequency multiplication effect of the Two-Phase topology. Looking at Figure 5, a full period happens approximately between 19.242075ms and 19.241075ms.

$$Freq_{Output} = \frac{1}{19.242075ms - 19.241075ms} = 1MHz$$

This is the expected 1MHz output frequency.

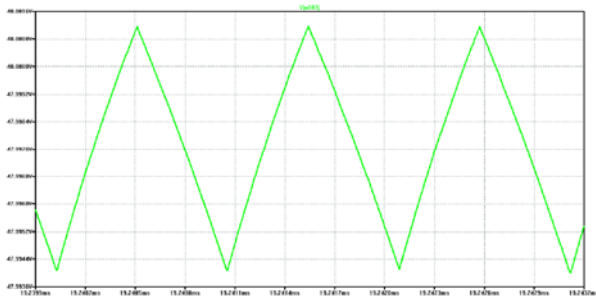

Fig. 5 Output Voltage Ripple

The unfiltered output currents are recorded by measuring the current through the schottky diodes individually. The resulting plots have distinct characteristics, they are discontinuous and trapezoid shaped as expected, see Figure 6. Notice that the currents are phase shifted by 180°. This is

because the multiphasing forces the main MOSFETs to switch alternately and evenly between the two phases, creating the phase shift. The same effect also occurs for the input current to each of the phases. This is represented by each individual inductor current at the input stage of each phase. The overlay waveforms of these inductor currents demonstrating the multiphase shifting is shown in Figure 7.

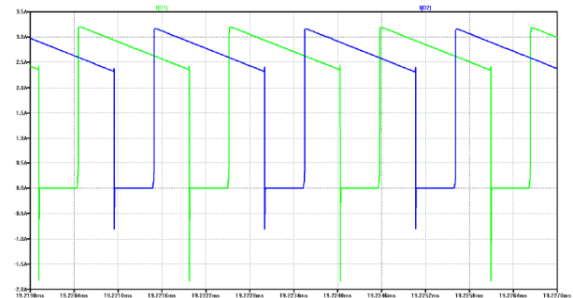

Fig. 6 Output currents

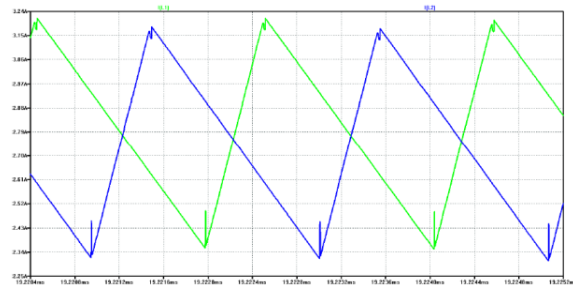

Fig. 7 Overlay inductor currents

One of the main focuses in power electronics is efficiency. Board layout, temperature and component tolerances all affect

the efficiency of a DC – DC converter. In the simulation those losses cannot be simulated. So it is apparent that the efficiency calculations done based on the simulation result will not be accurate, yet it gives a broad sense of the efficiency of the design. Efficiency plot from the simulation results is given in Figure 8 which shows efficiency above 90% above the 20% load.

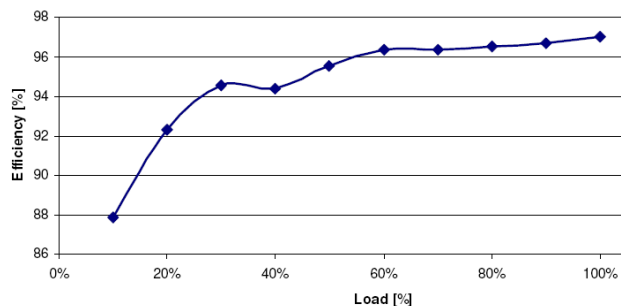

Fig. 8 Efficiency from simulation

#### IV. HARDWARE RESULTS

The hardware prototype was built on a pcb for reliability using both the top and bottom layers, see Figure 9. The large metal plate in the top layer is the ground trace for the converter. It is made specifically so that the ground traces only exist on the top of the board and close to the controller to provide good grounding and thermal conductivity. On the bottom layer there is only a few inches of ground trace to connect the remaining parts that does not fit on the top layer. The main focus of the PCB design is to separate the control nodes and switching nodes as far away as possible to reduce noise and ripple. On the top layer is where the pulse width modulator can be found. All of the control nodes are also found to the left and on the top layer of the board. To place the switching nodes as far away as possible it is designed so they are found to the right and on the bottom layer of the board. The use of top and bottom layers also has the purpose of getting better thermal flow and heat dissipation. As shown in Figure 9, most components are surface mounts except for the MOSFETs, inductors, and input capacitor.

Figure 10 shows the total input current and one of the inductor currents, and as expected the input current has half the peak to peak ripple as that of the individual inductor current. The peak to peak output voltage ripple was observed to be approximately 15mVpp which is significantly less than the required 1%, see Figure 11. The small output voltage ripple demonstrates one advantage of using multiphase since it not only shows a better quality dc output but also the reduced output filtering requirement. Load transient tests were also performed to see how fast the proposed converter recovers upon a step change in the load. Figure 12 shows both step up and step down responses of the converter on its output voltage. For the step down, the load was abruptly changed from 100% to 10% load. The duration of the output voltage transient was measured to be 150ms. The positive overshoot of 6V was also observed at the step change. As for the step up test, the load was changed from 10% load to full load. At the step change the output voltage exhibits about 7V negative overshoot which corresponds to the large current being drawn suddenly by the

load. The transient time lasts for 125ms before settling into a steady state. Also based on the hardware measurements, both line and load regulations were measured at 2.11% and 8.67%. These values exceed the targets of less than 1% for both line and load regulations as listed in Table I.

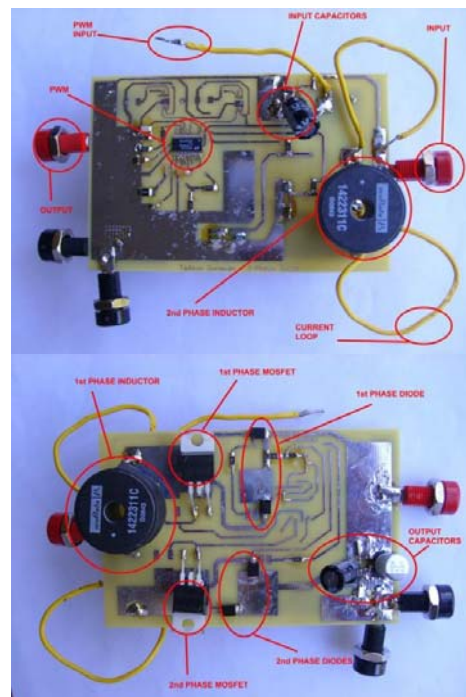

Fig. 9 2-Phase Boost Converter circuit board showing its components (a) top layer (b) bottom layer

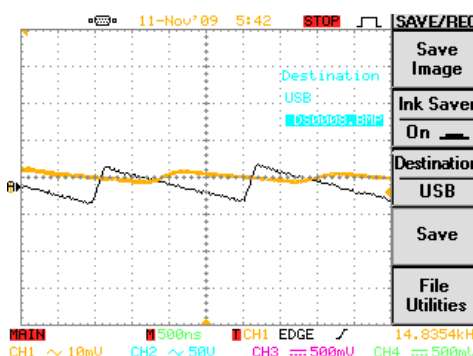

Fig. 10 Inductor current and input current waveforms

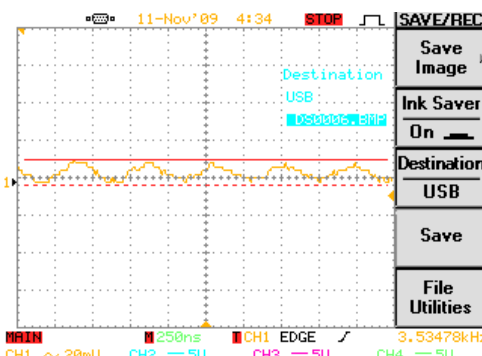

Fig. 11 Output voltage peak to peak ripple

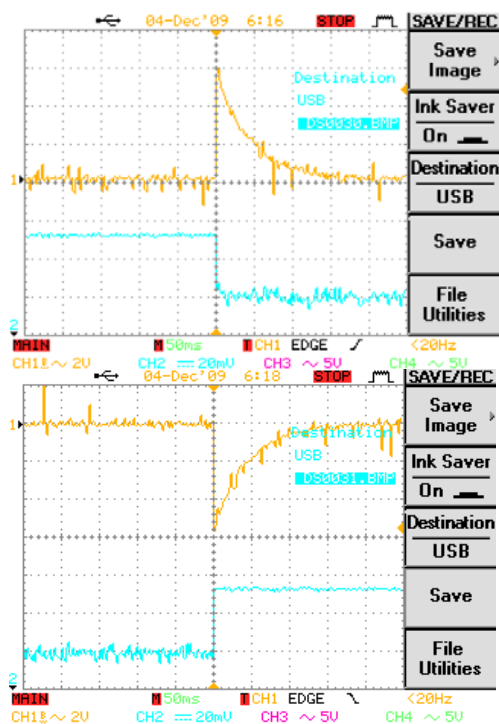

Fig. 12 Load transients: step down (top) and step up (bottom)

Lastly, the efficiency from the hardware measurements is plotted as shown in Figure 13. The actual 2-phase boost converter was found to be able to maintain its efficiency consistently around 97% above 30% load as depicted in Figure 9. This is actually better than the expected values found from the simulation and as listed in Table II where the 97% was only achieved at 100% load. This proves yet a major advantage of multiphasing specifically in reducing the conduction losses due to reduced rms currents in each phase compared to that if only one boost is used.

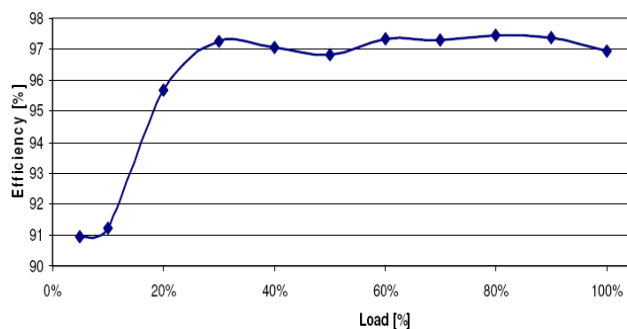

Fig. 13 Converter's overall efficiency

## V. CONCLUSION

In this paper, the benefits of using multiphase scheme for boost converter have been demonstrated. When simulated, the 2-phase boost converter was able to achieve all desired goals. Data obtained from hardware measurements indicated that the converter met all of the goals except for the line and load regulations. The line regulation may be improved by changing the current sense resistor to make the converter more sensitive to any change in the voltage. The load regulation on the other

hand may be improved by using higher quality output capacitors to be able to hold the voltage better and cleaner board layout to avoid crisscrossing of high frequency signals on the circuit board. Nevertheless, results from hardware measurements show the great potential of using multiphase for boost converter especially to achieve excellent overall converter's efficiency, peak to peak output ripple, and load transient response. It is also expected that the benefits may pay off more for much higher output power levels such as those used in renewable energy applications.

## REFERENCES

- [1]. Dodi Garinto. "New Converter Architectures with Multi-interleaving Technique for Future Microprocessors." IEEE INTELEC 2006: 28th Annual International Telecommunications Energy Conference, 2006.
- [2]. Tim Hegarty. "Benefits of Multiphasing Buck Converters - Part 2." Power Management Design Line, 23 Nov. 2007.
- [3]. Intel Corporation, Intel Technology Symposium, September 2001, Seattle, WA.
- [4]. X. Zhou, P. Xu, and F.C. Lee, "A High Power Density, High Frequency and Fast Transient Voltage Regulator Module with a Novel Current Sharing and Current Sharing Technique", Proceedings of IEEE APEC, 1999.
- [5]. X. Zhou, X. Zhang, J. Liu, P. Wong, J. Chen, H. Wu, L. Amoroso, F. C. Lee, and D. Chen, "Investigation of Candidate VRM Topologies for Future Microprocessors", IEEE Transactions on Power Electronics, Volume 15, Issue 6, Nov 2000 pp. 1172 - 1182.
- [6]. P. Xu, X. Zhou, P. Wong, K. Yao, and F.C. Lee, "Design and Performance Evaluation of Multi-Channel Interleaving Quasi-Square-Wave Buck Y. Panov, M. Jovanovic, "Design Considerations for 12-V/1.5-V, 50-A Voltage Regulator Modules". IEEE Transaction on Power Electronics, Volume 16, Issue 6, Nov. 2001, pp. 776 - 783.
- [7]. R. Miftakhutdinov, "Optimal Design of Interleaved Synchronous Buck Converter at High Slew-Rate Load Current Transients", Proceedings of Power Electronics Specialists Conference, 2001, Volume 3, June 2001, pp.1714 - 1718.
- [8]. Voltage regulator Module", Proceedings of HFPC, 2000, pp. 82-88.
- [9]. K. Agbossou, R. Simard, S. Kelouwani, A. Anouar, T. Bose, "Multiphase control of a boost converter for a renewable energy system", Proceedings of Canadian Conference on Electrical Engineering, May 2001, pp. 1029 - 1034.
- [10]. J. Lee, J. Kim; C. Won; S. Jang; Y. Jung "Soft Switching Multi-phase Boost Converter for Photovoltaic System", Proceedings of Power Electronics and Motion Control Conference, September 2008, pp. 1924 - 1928.