

# Determination of Q & R Matrices for Optimal Pitch Aircraft Control

N. Popovich, P. Yan

**Abstract**—In this paper, the process of obtaining Q and R matrices for optimal pitch aircraft control system has been described. Since the innovation of optimal control method, the determination of Q and R matrices for such system has not been fully specified. The value of Q and R for optimal pitch aircraft control application, have been simulated and calculated. The suitable results for Q and R have been observed through the performance index (PI). If the PI is small “enough”, we would say the Q & R values are suitable for that certain type of optimal control system. Moreover, for the same value of PI, we could have different Q and R sets. Due to the rule-free determination of Q and R matrices, a specific method is brought to find out the rough value of Q and R referring to rather small value of PI.

**Keywords**—Aircraft, control, digital, optimal, Q and R matrices

## I. INTRODUCTION

Q and R matrices are two weighting factors which influence the performance index (PI) in optimal control. In order to minimise the PI, Q and R should be adjust to some values. That means: there are no certain values of Q and R for minimised PI. A tuning method for getting a relatively small value of PI is applied in this paper. In order to do so, we should have a basic understanding of the system we are dealing with. When we are constructing a State-Space model for a system, we know that the element of state vector is related to the element of weighting vector. Furthermore, this requires in-depth understanding of the system rather than experimental examination of each element on Q and R matrices.

## II. PLANE MODEL OF THE PITCH MOTION

### A. Model

A simplified model of the pitch airplane control is given in Fig. 1.

If the elevator deflection angle has a small change over a short period, the input can be considered as a step input.

N. Popovich, M.Sc. (Eng) is a Senior Lecturer at AUT (Auckland University of Technology, Auckland, New Zealand (e-mail: nenad.popovich@aut.ac.nz).

Y. Peng, graduated at AUT, Auckland, New Zealand, with B.E (Honors), (e-mail: poning007@hotmail.com)

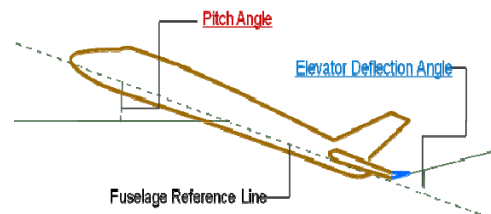

Fig. 1 Model of the pitching plane

### B. Assumptions

The State-Space model is based on the following assumptions.

To begin with, the atmosphere condition is symmetric and the propulsive forces  $T$  are constant. Also, there is not suddenly strong wind effecting. Secondly, the plane is pitching at a constant velocity initially. Finally, the airplane is in steady flight condition with extremely small deviations. Therefore, all the changes in moments, inertia, velocity, angular velocity, elevator deflection angle, pitching angle, and rolling angle are assumed to be very small, so that there is not going to have huge influence in the overall motion.

### C. Mathematical Description

The simulation of such a controller is based on a State-Space model. In order to obtain this model, we have to analyse the mechanical factors of motions of an airplane with the assumptions. Logically, the pitching motion consists of a horizontal motion along the x-axis, a vertical motion along the z-axis, and a rotational motion around y-axis. The resultant force is usually made up by aerodynamic force  $X$ ,  $Z$ , propulsive force  $T$ , and gravitational force  $G$ .

Fig. 2 shows the horizontal motion along x-axis with forces components.

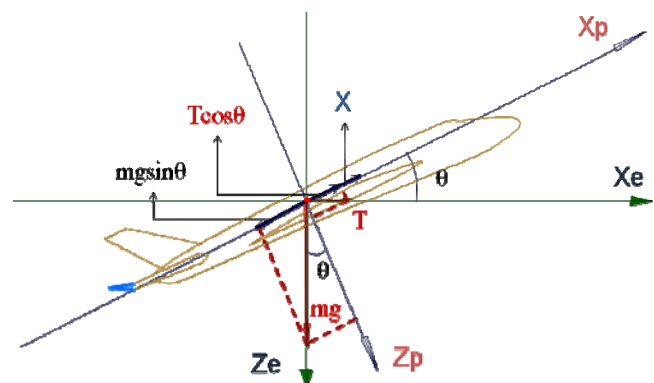

Fig. 2 Horizontal motion along x-axis

We rearrange a set of partial differential equations, as (1) shows, which are developed from the basic principles in [2].

$$X + T \cos \theta - mg \sin \theta = m(\dot{u} + qw - rv) \quad (1)$$

These equations include the aerodynamic forces in x-direction, as shown in Fig. 2. The final vision of expression for the resultant force along the x-axis is (2).

$$\Delta \dot{u} = \frac{\partial X_T}{\partial u} \Delta u + \frac{\partial X_T}{\partial w} \Delta w + (g \cos \theta_0) \Delta \theta + \frac{\partial X_T}{\partial \delta_e} \Delta \delta_e \quad (2)$$

Fig. 3 shows the vertical motion along z-axis with forces components.

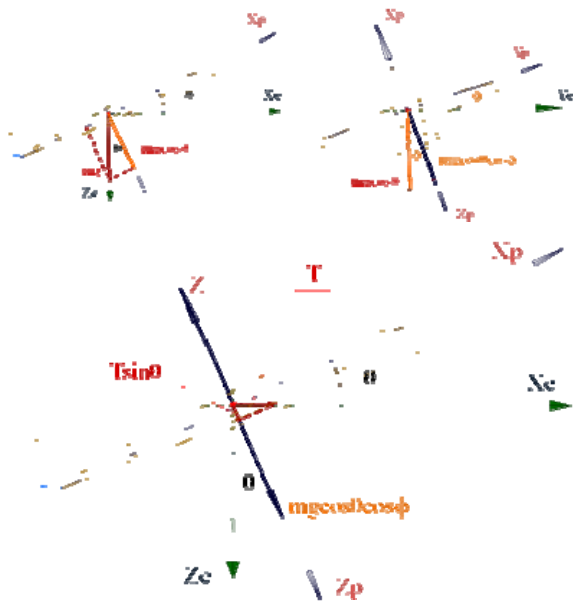

Fig. 3 Vertical motion along z-axis

Through the analysis of force acting on z-axis, we get equation (3).

$$Z - T \sin \theta - mg \cos \theta \cos \phi = m(\dot{w} + pv - qu) \quad (3)$$

The final version of expression for the resultant force along the z-axis is represented as (4).

$$\Delta \dot{w} = \frac{\partial Z_T}{\partial u} \Delta u + \frac{\partial Z_T}{\partial w} \Delta w + \frac{\partial Z_T}{\partial q} \Delta q + (g \sin \theta_0) \Delta \theta + \frac{\partial Z_T}{\partial \delta_e} \Delta \delta_e \quad (4)$$

Taking angular velocities, the moment of inertia along x, y and z-axis, and the product of inertia into account, we produce the equation regarding to moment about y-axis as (5).

$$M = I_y \dot{q} - I_{xz} \dot{r} + rp(I_x - I_z) - I_{xz}(p^2 - r^2) \quad (5)$$

Equation (6) is the final expression for the resultant moment about y-axis.

$$\Delta \dot{q} = \frac{\partial M}{\partial I_y} \Delta u + \frac{\partial M}{\partial w} \Delta w + \frac{\partial M}{\partial q} \Delta q + \frac{\partial M}{\partial \delta_e} \Delta \delta_e \quad (6)$$

Finally, the relationship of the pitch angle and pitch rate is defined with a simple differential equation, which is (7).

$$\Delta \dot{\theta} = \Delta q \quad (7)$$

As in [4], if all (2), (4), (6), and (7) are combined together in the compact form of matrix expression we can obtain the State-Space model of the plane, (8).

$$\begin{bmatrix} \Delta \dot{u} \\ \Delta \dot{w} \\ \Delta \dot{q} \\ \Delta \dot{\theta} \end{bmatrix} = \begin{bmatrix} \frac{\partial X_T}{\partial u} & \frac{\partial X_T}{\partial w} & 0 & g \cos \theta_0 \\ \frac{\partial Z_T}{\partial u} & \frac{\partial Z_T}{\partial w} & \frac{\partial Z_T}{\partial q} & g \sin \theta_0 \\ \frac{\partial M}{\partial u} & \frac{\partial M}{\partial w} & \frac{\partial M}{\partial q} & 0 \\ 0 & 0 & 1 & 0 \end{bmatrix} \begin{bmatrix} \Delta u \\ \Delta w \\ \Delta q \\ \Delta \theta \end{bmatrix} + \begin{bmatrix} \frac{\partial X_T}{\partial \delta_e} \\ \frac{\partial Z_T}{\partial \delta_e} \\ \frac{\partial M}{\partial \delta_e} \\ 0 \end{bmatrix} \Delta \delta_e \quad (8)$$

In [1] and [6], State-Space model of pitching motion, under certain prototype of Boeing 747 with 637000lb in weight at nominal speed  $U_0=830\text{ft/sec}$  and 20000ft in height, gives us (9).

$$\begin{bmatrix} \dot{u} \\ \dot{w} \\ \dot{q} \\ \dot{\theta} \end{bmatrix} = \begin{bmatrix} -0.00643 & 0.0263 & 0 & -322 \\ -0.0941 & -0.624 & 820 & 0 \\ -0.000222 & -0.00153 & -0.668 & 0 \\ 0 & 0 & 1 & 0 \end{bmatrix} \begin{bmatrix} u \\ w \\ q \\ \theta \end{bmatrix} + \begin{bmatrix} 0 \\ -327 \\ -2.08 \\ 0 \end{bmatrix} \Delta \delta_e \quad (9)$$

In order to obtain the pitch angle as the output y, we have (10).

$$y = \begin{bmatrix} 0 & 0 & 0 & 1 \end{bmatrix} \begin{bmatrix} u \\ w \\ q \\ \theta \end{bmatrix} \quad (10)$$

### III. DISCRETE TIME PITCH CONTROL MODEL

#### A. Discrete time State-Space model

We have obtained the continuous time State-Space model as (9) and (10). Since the controller is based on a discrete time model, we have to convert it to the form in (11), where  $x(k)$  represents the state variables:  $u(k)$ ,  $w(k)$ ,  $q(k)$ , and  $\theta(k)$ .

$$\begin{cases} x(k+1) = Gx(k) + H\delta_e(k) \\ y(k) = Cx(k) \end{cases} \quad (11)$$

We did the conversion by using Matlab with a sampling time of 0.1 sec. The results are:

$$G = \begin{bmatrix} 0.8705 & -0.1574 & -9.4e-4 & -1.64e-5 \\ 0.09352 & 0.992 & -4.8e-5 & -8.38e-7 \\ 4.78e-3 & 0.0997 & 1 & -2.83e-8 \\ 1.61e-4 & 4.993e-3 & 0.1 & 1 \end{bmatrix}$$

$$H = \begin{bmatrix} 0.09352 \\ 4.784e-3 \\ 1.613e-4 \\ 4.059e-6 \end{bmatrix}$$

$$C = [0 \quad 2.08 \quad 1.261 \quad 0.01298]$$

### B. Input-Elevator Deflection Angle

If the movement of elevator deflection angle is too big and fast, it could cause damage on the mechanical gears. Thus, the elevator deflection angle is assumed to be changed at rather small steps. The more realistic input will be sum of a ramp and step functions. We can activate either input by using a single switch in Simulink, as illustrated in Fig. 4.

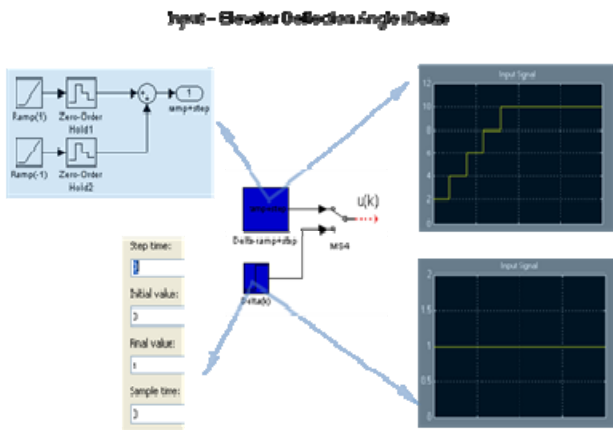

Fig. 4 Simulated input model in Simulink

### C. Performance Index (PI) and Optimal Pitch Controller

PI can be generally understood as the difference between actual system performance and desired system performance, which can be represented by the expression (12).

$$\Delta J = J - \hat{J} \quad (12)$$

If we define V as the function of system performance during one time interval k, combining (12), we get the derivative of PI shown in (13).

$$\partial J = \sum_{k=k_0}^{N-1} \left[ \frac{\partial V(\hat{x}(k), \hat{x}(k+1), k)}{\partial \hat{x}(k)} \partial x(k) + \frac{\partial V(\hat{x}(k), \hat{x}(k+1), k)}{\partial \hat{x}(k+1)} \partial x(k+1) \right] \quad (13)$$

' $\hat{\cdot}$ ' indicates the desired value.

After we expand (13) and rearrange it, we obtain (14).

$$\partial J = \sum_{k=k_0}^{N-1} \left[ \frac{\partial V(\hat{x}(k), \hat{x}(k+1), k)}{\partial \hat{x}(k)} + \frac{\partial V(\hat{x}(k-1), \hat{x}(k), k-1)}{\partial \hat{x}(k)} \right] \partial x(k) + \left[ \frac{\partial V(\hat{x}(k-1), \hat{x}(k), k-1)}{\partial \hat{x}(k)} \partial x(k) \right]_{k=k_0}^{k=N} \quad (14)$$

A minimum point or a maximum point exists where the derivative of that point equals to zero. It is considered there is no maximum point in performance index. When the derivative of PI equals zero, the first and second parts of (14) have to satisfy the condition as shown in (15) and (16).

$$\frac{\partial V(\hat{x}(k), \hat{x}(k+1), k)}{\partial \hat{x}(k)} + \frac{\partial V(\hat{x}(k-1), \hat{x}(k), k-1)}{\partial \hat{x}(k)} = 0 \quad (15)$$

$$\left[ \frac{\partial V(\hat{x}(k-1), \hat{x}(k), k-1)}{\partial \hat{x}(k)} \partial x(k) \right]_{k=k_0}^{k=N} = 0 \quad (16)$$

As an outcome, the above expressions are the basic conditions for existence of a minimum performance index.

In order to find the optimal pitch controller parameters, we define a performance index (PI), in the form from [5].

$$J = \frac{1}{2} x'(N) P x(N) + \frac{1}{2} \sum_{k=0}^{N-1} [x'(k) Q x(k) + u'(k) R u(k)] \quad (17)$$

To minimize this performance index (17), we apply the Euler-Lagrange equation (15).

Now, let us consider L (a step before the final step) with Lagrange multiplier which is used for simplification. We are able to acquire (18)

$$L(x(k), u(k), \lambda(k+1)) = \frac{1}{2} x'(k) Q x(k) + \frac{1}{2} u'(k) R u(k) + \lambda'(k+1) [Gx(k) + Hu(k) - x(k+1)] \quad (18)$$

By combining the Hamiltonian Equation, which is defined as (19), with derivative of (18), the conditions for the minimum are developed and expressed with the following set of equations:

$$H(x(k), u(k), \lambda(k+1)) = \frac{1}{2} x'(k) Q x(k) + \frac{1}{2} u'(k) R u(k) + \lambda'(k+1) [Gx(k) + Hu(k)] \quad (19)$$

After performing substitution and differentiation, and let  $\hat{\lambda}(k) = P(k)x(k)$ , Riccati matrix P is solved.

$$P(k) = G'P(k+1)[I + HR^{-1}H'P(k+1)]^{-1}G + Q \quad (20)$$

Equation (20) involves two matrix inversions. Technically, this is likely to slow down a system. Thus, we try to rearrange it to the form shown as (21), which only contains one matrix inversion.

$$P(k) = G^T \{ P(k+1) - P(k+1)H[H^T P(k+1)H + R]^{-1} H^T P(k+1) \} G + Q \quad (21)$$

A state feedback controller is simulated as in Fig. 5. The ending point  $N$  will be set to 20 sec during the observation.

$$u(k) = -Kx(k) \quad (22)$$

where in (22),  $K$  is a state feedback matrix.

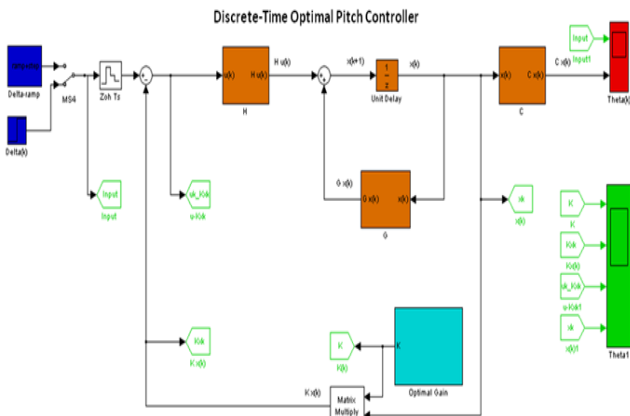

Fig. 5 Simulated model in Simulink

Through the mathematical manipulation of (17), (21), and (22), we can obtain (23), which is known in [3] and [7] as a Kalman gain.

$$K = [H(k-1)'P(k)H(k-1) + R(k-1)]^{-1} H(k-1)'P(k)G(k-1) \quad (23)$$

Note that state feedback gain applying in this discrete time optimal pitch controller, in (22) is actually one step after the Kalman gain. However, it does not have negative impact on this system because the terms making up this gain do not contain time varying terms. As we can see, matrices  $H$ ,  $R$ , and  $G$  are all constant matrices. No matter what step we take, these matrices will not change in respect to time. As a result, the Kalman gain is able to be applied on this pitch controller, although it is one step forward to the original one.

When (23) is applied as a state feedback, the gains are not constant at the beginning. They are shown as a dynamic feedback gain in Fig. 6.

After a short period, the gains converge to constant. This is known as steady state feedback gain.

If these gains in steady state are directly connected to the feedback, the response of theta is shown in Fig. 6.

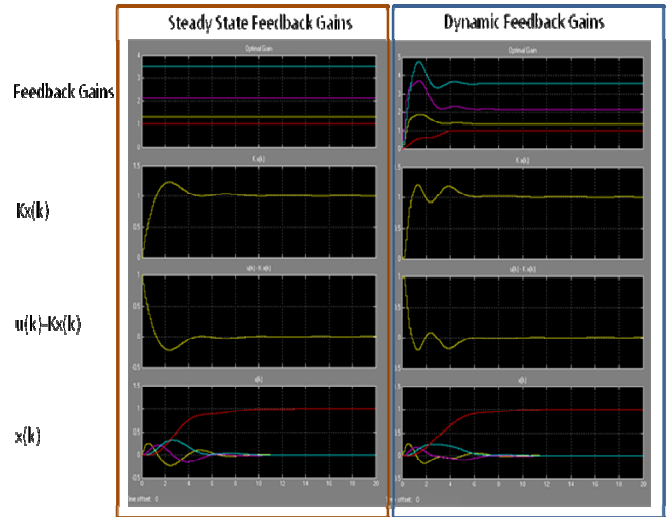

Fig. 6 Response of steady state feedback gain dynamic feedback gains

In [8], by comparing it to the response of theta with dynamic feedback gains, we can see that both response patterns of theta are very similar. Without much effect on output theta, steady state feedback gains also provide less oscillation.

There is usually an advantage for a system to have less oscillation. In realistic, if the state feedback gain for a system is pre calculated, the overall system may response faster with assigning the steady state gain to it directly.

#### IV. DETERMINATION OF $Q$ AND $R$ MATRIX

##### A. Minimized value of PI

To begin with, we should keep the properties of  $Q$  and  $R$  matrices in mind.  $Q$  should strictly obey to the rule. It is that  $Q$  matrix has to be  $n \times n$  symmetric, positive definite or positive semi-definite.  $R$  should be positive definite due to that it weights the input.

Simulation is done by using Simulink. The observation period is set to be 20 sec during the simulation. Thus, there is a final Riccati value for  $P$  at time  $N$ . Taking Riccati matrix  $P$  into account, a simulation block which returns dynamic gain  $K$  and Riccati Matrix  $P$  is designed as Fig. 7.

Simulation to calculate the value of PI is done, using a block diagram shown in Fig. 8.

**State Feedback**

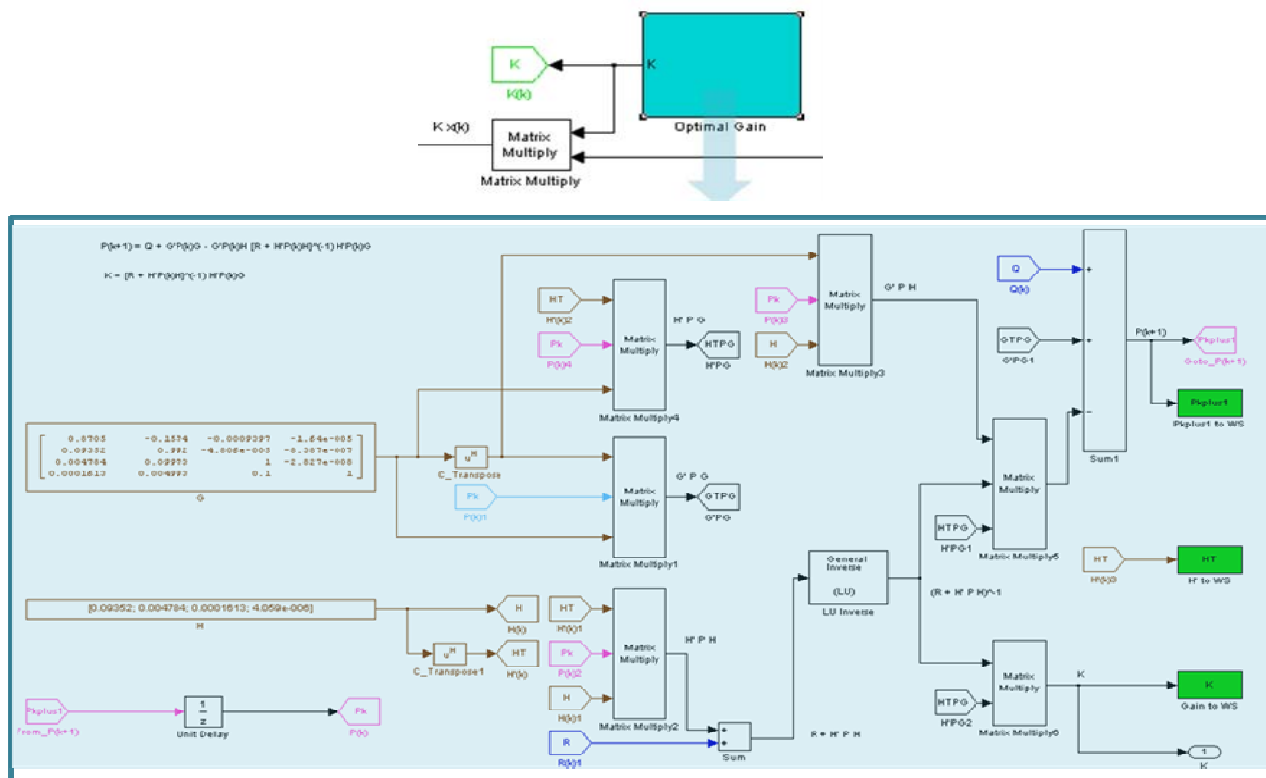

Fig. 7 Simulation of state feedback

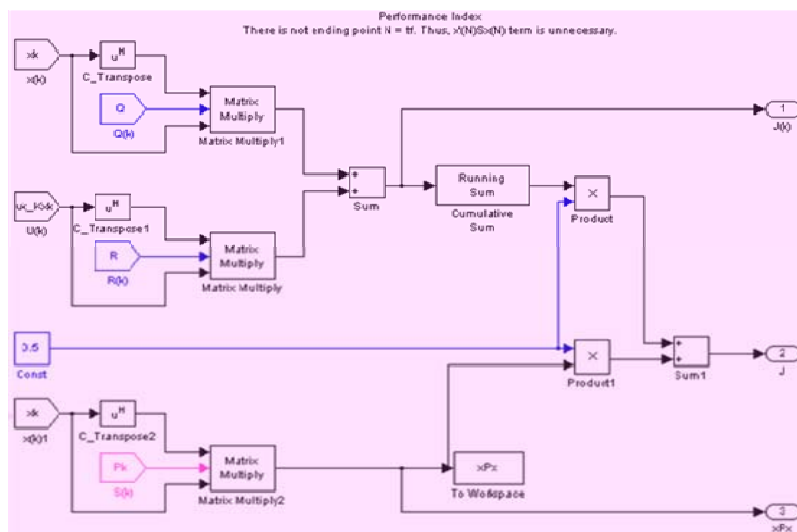
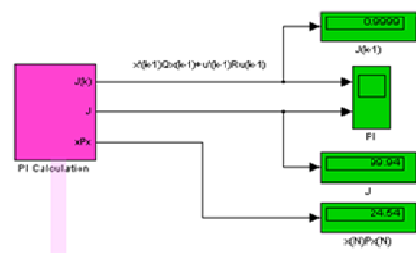

Fig. 8 PI calculation

**B. Determination of Q**

Firstly, we tune the main diagonal of this matrix. After setting it to be an 'eye' matrix, we run the simulation and see the response of the output. Due to the reason that the velocity components along x and z axis have less effect on the pitching motion, the pitch rate and the pitch angle become the major concern. Increase in the weighting factor of pitch angle, sitting on the 4<sup>th</sup> row and 4<sup>th</sup> column of  $Q$  matrix, raises the

difference between desired pitch angle and simulated pitch angle at the final time. Thus, it should be only adjusted at the range of 0.5 to 2. Furthermore, pitch rate is the dominant factor that eliminates the overshoot of pitch angle. If we increase the weighting factor for pitch rate, the overshoot of pitch is reduced significantly.

It comes to the next step after we tune the weighting factor  $Q$  on its main diagonal. Mathematically, there is a solid relationship between the pitch angle and pitch rate. The output

curve will be smooth if the pitch rate and the pitch angle are stressed among the state variables of velocity components along x and z axis. As an outcome, increase in the weight factor related to the velocity component along z axis makes contribution to the achievement of better output. Nevertheless, the output theta will start fluctuating, if the velocity component on x axis and pitch rate is over-stressed.

Overall, the weighting factors are dependent on the importance of that corresponding state variable. Beside the main diagonal of matrix  $Q$ , zero elements indicate there is little influence on pitch angle. The more important the state variable, the greater the value of weighting factor is.

$$\begin{pmatrix} 1 & \times & \times & \rightarrow \{0 \text{ to } 3\} \\ & 1 & \times & \times \rightarrow \{0 \text{ to } 3\} \\ & & \times & \times \\ & & & 1 \end{pmatrix} \quad (24)$$

Associated with the techniques above, we can experimental test each vital element in (24) with symbol "cross", to observe the change in value of PI. Full data is shown in Appendix A.

The summary of change in PI referring to such properties, such as overshoot, is presented in TABLE I.

TABLE I  
 SUMMARY OF CHANGES CAUSED BY INCREASE IN VALUES OF ELEMENTS IN  $Q$  MATRIX

Element Position	Output - Theta	Settling Time $T_s$	Overshoot	PI
4, 4	↓	↓	↓	↑
3, 3	~	↑	↓	↓
2, 2	~	~	✓	↑
1, 1	~	~	↑	↑
3, 4	~	~	~	✓
2, 4 ∈ (0, 3)	✓	↑	↑	✓
1, 4	~	~	↑	↑
2, 3	~	↑	↓	↓
1, 3 ∈ (0, 3)	~	↑	↓	↓
1, 2	~	~	↓	↓

- ~ - Almost no difference
- ↑ - Increase
- ↓ - Decrease
- ✓ - Slightly Increase
- ✗ - Slightly Decrease

### C. Determination of $R$

There is only one dimension for  $R$  matrix. As we decrease the value of  $R$ , the final value of output is decreased significantly. TABLE II shows the trend of performance index, theta, overshoot and settling time once  $R$  increases. The results of obtaining such data are presented in Appendix B.

TABLE II

SUMMARY OF CHANGES CAUSED BY INCREASE IN VALUE OF  $R$

Weighting Factor	Output - Theta	Settling Time $T_s$	Overshoot	PI
$R$	↓	↑	↑	↑

When  $R$  is set to be zero, the value of performance index becomes zero. It is reasonable because the reference input is ignored by the system. Although it satisfies our criterion for optimal pitch controller, we will not adopt this value due to the reason that reference input is necessary and it generally has a value of 1.

### D. Results

These are the optimal values of  $Q$  and  $R$  matrices, with a PI value of 99.65.

$$Q = \begin{bmatrix} 1 & 10 & 3 & 0 \\ 10 & 1 & 20 & 2.5 \\ 3 & 20 & 10 & 1.1 \\ 0 & 2.5 & 1.1 & 1 \end{bmatrix}$$

$$R = 0.87$$

The output Theta of controller respecting step input signal Delta is presented in Fig. 9.

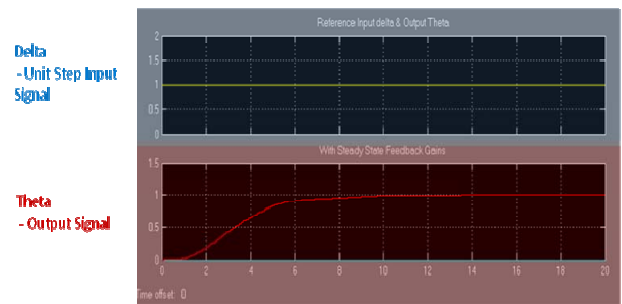

Fig. 9 Response to a unit step input

Fig. 10 shows us the response corresponding to a realistic elevator deflection angle.

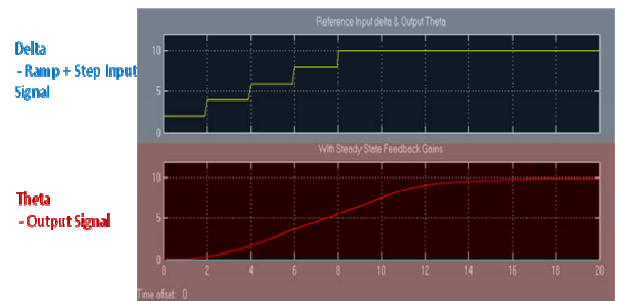

Fig. 10 Response to a ramp plus step input

In conclusion of the results:

The output (Theta) is non-oscillatory, so there is no overshoot. From Fig. 9, the rising time and setting time is about 3.5 sec and 7 sec, respectively.



In terms of Fig. 10, the more realistic input has a response with settling time at 14 sec. There is a delay about 8 sec before Theta reaches the exact value of set point of Delta.

#### V. APPLYING 'dlqr' COMMAND IN MATLAB

This experiment is conducted to see if the simulation of optimal pitch control has the same results as 'dlqr' command does. If the results are very similar, the structure of simulation can be proved to be successfully constructed.

The full name of a built in Matlab command 'dlqr' is: Discrete Linear Quadratic Regulator. The default performance index (PI) for this command is expressed in (25), which involves cross term matrix M. As the original PI we defined in (17), M has to be set to zero when we conduct the 'dlqr' command.

$$J = \frac{1}{2} x'(N) P x(N) + \frac{1}{2} \sum_{k=0}^{N-1} [x'(k) Q x(k) + u'(k) R u(k) + 2x'(k) M u(k)] \quad (25)$$

TABLE III indicates two pairs of values of K and P matrices. As a result, the great similarity appears between 'dlqr' command and simulation using Simulink.

TABLE III  
 COMPARISON BETWEEN SIMULATION AND 'DLQR' COMMAND

Matrix Q, R		$Q = \begin{bmatrix} 1 & 10 & 3 & 0 \\ 10 & 1 & 20 & 2.5 \\ 3 & 20 & 10 & 1.1 \\ 0 & 2.5 & 1.1 & 1 \end{bmatrix}$ $R = 0.37$														
Simulation from Simulink	K	[1.325	2.13	3.542	0.9995]											
	P	[12.481	24.363	34.001	9.321	24.363	-59.79	58.725	26.432	34.001	58.725	-92.97	11.903	9.3213	26.432	11.903
'dlqr' Command	K	[1.3253	2.1302	3.542	0.9995]											
	P	[12.481	24.363	34.001	9.321	24.363	-59.79	58.725	26.432	34.001	58.725	-92.97	11.903	9.3213	26.432	11.903

#### VI. CONCLUSION

This paper has demonstrated the optimal control method for the digital pitch aircraft controller. The method used to determine Q and R matrices is considered to be the core of this paper. Weighting factors Q and R in optimal control system can be determined by fully understanding the target model. By tuning the relative elements in those matrices, we are able to obtain the one of the best values of Q and R matrices, which corresponds to a minimised PI value. Design of such pitch controller is one of the examples where this approach can be applied. A procedure for this method is suggested. A simulation of the optimal digital control for the aircraft has been performed.

#### APPENDIXES

##### Appendix A. Experimental results for elements of Q matrix

Element Position	Value	Theta	Ts	OS (%)	PI
4, 4	5	0.5	9	28	233.6
	10	0.35	8	/	241.8
3, 3	5	1.1	15	70	200.2
	10	1.1	17	45	197
2, 2	5	1.1	12	125	221.8
	10	1.1	13	110	227
	15	1.1	14	105	231.8
1, 1	5	1.1	13	150	262.8
	10	1.2	13	170	306.2
	15	1.25	15	180	340.8
3, 4	5	1.08	13	20	129.6
	10	1.08	12	20	123.6
	15	1.08	12	20	121.6
2, 4	5			Instable	
	2	1.02	20	90	139.4
	3			Instable	
1, 4	1.5	1.09	>20	83	149.1
	5	1.08	18	220	1.42E6
	10	1.08	15	160	1.81E8
2, 3	1.5	1.08	13	90	167.9
	5	1.1	9	67	149.2
	10	1.1	10	48	137.4
1, 3	5			Instable	
	2	1.1	>15	93	157.3
	3			Strong Oscillation	
	0	1.1	<15	110	195.3
1, 2	1	1.1	11	123	209.8
	5	1.1	11	109	192.6
	10	1.1	11	90	182.1

'4, 4' means the position at 4<sup>th</sup> row and 4<sup>th</sup> column of Q matrix. N=20 sec.

##### Appendix B. Experimental results for element of R matrix

Element Position	Value	Theta	Ts	OS (%)	PI
1, 1	0.5	0.76	12	100	114.5
	1.0	1.1	14	125	217.1
	2.0	1.5	16	175	417.3

'1, 1' means the position at 1<sup>st</sup> row and 1<sup>st</sup> column of R matrix. N=20 sec

#### REFERENCES

- [1] G. F. Franklin, D. J. Powell, and A. E. Naeini, Feedback Control of Dynamic Systems. New Jersey, The United States of America: Pearson Prentice Hall, Pearson Education, Inc, 2006.
- [2] J. L. Meriam, and L. G. Kraige, Engineering Mechanics Dynamics. The United States of America: John Wiley & Sons, Inc, 2003.
- [3] D. S. Naidu, Optimal Control Systems. The United States of America: CRC Press LLC, 2003.
- [4] R. C. Nelson, Flight Stability and Automatic Control. The McGraw-Hill Companies, Inc, 1998.
- [5] K. Ogata, Discrete Time Control Systems. New Jersey, The United States of America: Prentice-Hall, 1995.
- [6] K. Ogata, Modern Control Engineering. New Jersey: Prentice-Hall, Inc, 2002.
- [7] S. M. Shinnars, Advanced Modern Control System Theory and Design. John Wiley & Sons, Inc, 1998.
- [8] N. Popovich, P. Yan, Optimal Digital Pitch Aircraft Control, International Conference, ICCESSE 2010, Singapore, December 18-20, 2010.