

Using Hybrid System of Ground Heat Exchanger and Evaporative Cooler in Arid Weather Condition

Vahid Khalajzadeh¹, Ghassem Heidarinejad²

Abstract—In this paper, the feasibility study of using a hybrid system of ground heat exchangers (GHE) and direct evaporative cooling system in arid weather condition has been performed. The model is applied for Yazd and Kerman, two cities with arid weather condition in Iran. The system composed of three sections: Ground-Coupled-Circuit (GCC), Direct Evaporative Cooler (DEC) and Cooling Coil Unit (CCU). The GCC provides the necessary pre-cooling for DEC. The GCC includes four vertical GHE which are designed in series configuration. Simulation results show that hybridization of GCC and DEC could provide comfort condition whereas DEC alone did not. Based on the results the cooling effectiveness of a hybrid system is more than unity. Thus, this novel hybrid system could decrease the air temperature below the ambient wet-bulb temperature. This environmentally clean and energy efficient system can be considered as an alternative to the mechanical vapor compression systems.

Keywords—Computational Fluid Dynamics (CFD), Cooling Coil Unit (CCU), Direct Evaporative Cooling (DEC), Ground Coupled Circuit (GCC)

I. INTRODUCTION

CLIMATIC changes due to global warming, the depletion of fossil fuel resources and demands for reducing pollution are the motivations for replacing conventional energy resources with natural resources. Methods of passive cooling such as ground cooling can be economical alternatives, which are used as a pre-cooler in conventional systems. The Ground Heat Exchangers (GHEs) are among the fastest growing applications of the renewable energy in the world. The GHEs are the relatively constant temperature geothermal sinks for heating or cooling purposes. It is important to mention that, the GHEs faced restrictions when the consumers reject more heat than they extract over the annual cycle. Therefore, it causes an increase in the size of the ground loop heat exchanger. To decrease the total size of the ground loop and increase the efficiency of GHEs, a hybrid ground coupled cooling system is used.

Proper modeling of a GHE is a vital part of a researcher's mission. Several analytical and numerical methods have been widely applied in such a field due to the considerable advantage of solving complex heat-transfer problems. At

present, there are a several models for the modeling of the GHE. For example in order to predict the thermal behavior of the GHEs and surrounding soil formations, various studies have been reported by Mei and Emerson [1], Muraya et al. [2], Rottmayer et al. [3], Cui et al. [4], Lee and Lam [5] and Li and Zheng [6]. Also, several researches have focused on using a hybrid ground coupled HVAC air conditioners. For example, based on the short time-step model for the GHEs, Yavuzturk [7] studied the performance of a hybrid geothermal heat pump systems coupled with a cooling tower. He showed that his system could provide better cooling water than the stand-alone system. Gasparella et al. [8] reported the operation of a combined liquid desiccant and geothermal heat pump system in Italy, with different operational modes in various seasons and different weather conditions. Ozgener and Hepbasli [9] discussed the cost of a solar-assisted geothermal heat pump system. They show that by using a hybrid system the cost of energy consumption is decreased significantly. Chiasson and Yavuzturk [10] analyzed the performance of a geothermal heat pump systems coupled with a solar thermal collectors and commented that in order the hybrid systems to become economically viable, the drilling costs for the boreholes should exceed 32.81 \$/m. Lee and Lam [11] developed a computer model for a novel ground-coupled liquid desiccant air conditioner. They found that by using a hybrid system, the total length of the ground circuit was decreased significantly. As far as it is known, the DEC air conditioners are the oldest and the most widespread cooling systems. Nevertheless, the DEC systems have some usage limitations especially in a humid weather condition. In order to use a DEC systems in a more severe climate conditions, they were mostly coupled with the other cooling air conditioning systems. For example, Heidarinejad et al. [12] designed a hybrid system of a DEC and an indirect evaporative cooling (IEC) system. Based on their experimental result, the proposed hybrid system is more efficient than DEC, at the different weather conditions. In the other study, Heidarinejad et al. [13] proposed a novel hybrid system, which was composed of a Ground coupled heat exchangers and DEC system. Their system was environmentally clean and efficient. They also showed that their hybrid system could fulfill comfort condition whereas direct evaporative alone was not able to provide summer comfort condition. In addition, Heidarinejad et al [14] suggested a cooling systems macrozonation for a multi-climate country. The investigated systems in this paper cover almost all zones in such a multi-climate country. This research in addition to the other studies [12, 13] can provide a

1- MAPNA Group-Monenco Iran Consulting Engineers Co, No. 231, Mirdamad Blvd., TEHRAN - IRAN (Tel: +98 21 8198 1001-2, fax: +98 21 2290 8597-8, P O. Box 19395/6448, E-mail address: vahid2003kh@yahoo.com).

2- Department of Mechanical Engineering, Tarbiat Modares University, Tehran, Iran (Tel: +(9821) 82883361, fax: +(9821) 88005040, P.O. Box 14115-143, E-mail address: gheidar@modares.ac.ir)

ground research on feasibility usage of the different cooling systems in different climates. In order to extend the DEC systems applicability and reduce the necessary size of the ground loop heat exchanger, in this study a novel hybrid system of the DEC system and GHEs are proposed. The proposed system composed of three main parts: the Ground-Coupled-Circuit (GCC), the Cooling-Coil-Unit (CCU) and the DEC system. Due to have an accurate prediction of the complex heat-transfer process in the ground region, a three-dimensional computational model with a very fine grid and a very short time-interval was carried out. At first, each part of the proposed hybrid system was simulated and validated separately; then all parts were put together and the hybrid system simulated integrally.

II. SYSTEM DESCRIPTION

As seen in Fig. 1-(a), a hybrid cooling system consists of the GCC, which is coupled with the aid of a CCU to a DEC system. The fluid goes through the GCC and rejects its heat to the surrounding ground formation. When the circulating fluid leaves the GCC it becomes colder and afterward enters to the CCU. At the other side, the ambient air enters to the CCU (point 1), and transfers its heat to the circulating cold water. Then enters to the DEC system (point 2), and finally, after evaporation process, colder air exits from the DEC system (point 3). In the proposed hybrid system, a DEC system includes a porous pad which is wetted by dripping water (see Fig. 1-(b)). It is worth mentioning that width and height of the pad are equal to dimensions of the cooling coil. In other words, it is assumed that air passes through the same channel. Fig. 1-(c) presents the schematic of the mentioned processes on a psychrometric chart.

III. MODELING OF THE GCC

A. Undisturbed Ground Temperature Profile

Ground temperature is affected mainly by variations in air temperature and solar radiation. Under influence of these effects, the undisturbed ground temperature fluctuates daily and annually. The annual variation of the surface ground temperature could be estimated using a sinusoidal function [15].

$$T(Z, \tau) = \bar{T}_G + A_{GS} \cos\left(\frac{2\pi}{365}(\tau - \tau_0)\right) \quad (1)$$

The Kusuda formula [15] which is based on the solution of one-dimensional transient heat conduction in semi-infinite solid with sinusoidal surface temperature is presented as follow:

$$T(Z, \tau) = \bar{T}_G + A_{GS} \exp\left(-Z \sqrt{\frac{\pi}{365 \alpha_s}}\right) \times \cos\left(\frac{2\pi}{365}\left(\tau - \tau_0 - \frac{Z}{2} \sqrt{\frac{365}{\pi \alpha_s}}\right)\right) \quad (2)$$

Where, $T(Z, \tau)$ is the undisturbed ground temperature at time τ and depth (Z), \bar{T}_G is the mean ground temperature,

A_{GS} is the annual amplitude of the ground surface temperature, τ_0 is a time lag (days) from an arbitrary starting date, and $\bar{\alpha}_s$ is the average thermal conductivity of the soil. As seen in Fig. 2 the undisturbed ground temperature is changing down to 10m in depth after which the ground temperature becomes constant. Unlike most previous researches, which had been assuming a constant undisturbed ground temperature for their purposes, in this study, the undisturbed ground temperature is assumed to be variable with depth.

(a)

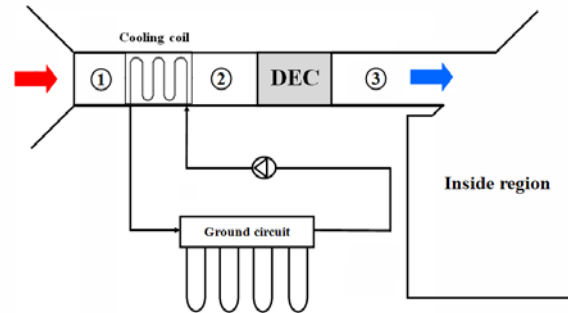

(b)



(c)

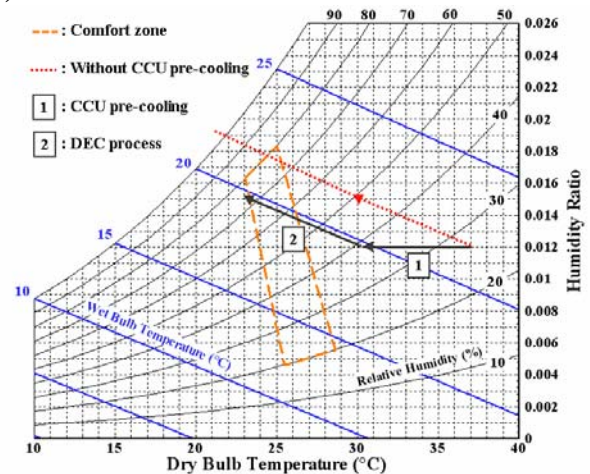

Fig. 1 Hybrid GCHE and DEC cooling system, (a) Schematic diagram of hybrid system (b) Schematic of DEC pad (c) Adiabatic process on a psychrometric chart

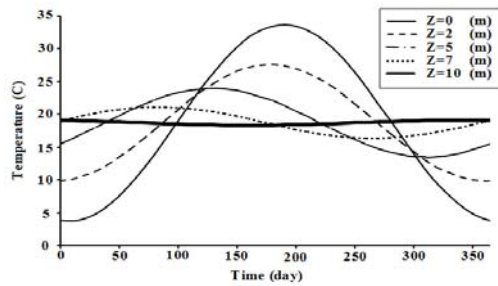

Fig. 2 Ground temperature profile at different depth

B. CFD Simulation of the GHE

A GHE interacts thermally not only with the grouts in the borehole but also with the surrounding ground formation. For convenience of modeling, the volume of ground that is affected by the vertical ground heat exchangers -the ground storage volume- considered as a three dimensional rectangular cylinder with a height greater than the depth of the boreholes to ensure that the soil at the bottom boundary is not affected by the GHE during the time of simulation. Schematic computational geometry is presented in Fig. 3.

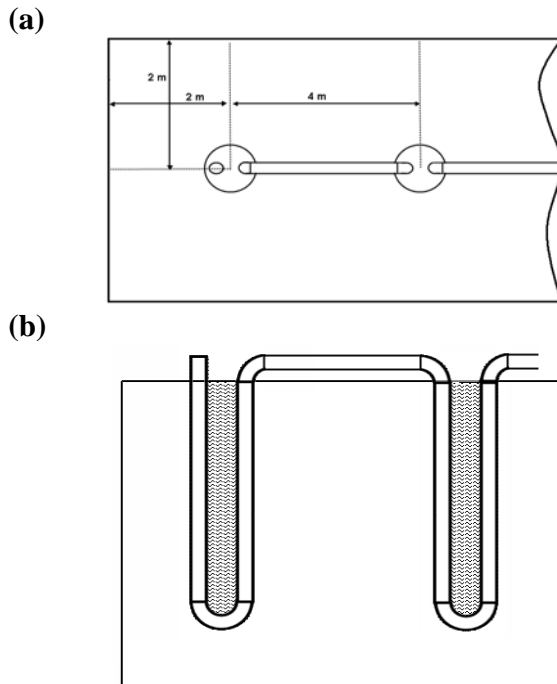

Fig. 3 Schematic of computational domain (a) top view (b) section in the symmetry plane

A number of assumptions are made to develop the model and brief discussions of these assumptions have been mentioned as follow:

- The grout and the ground formation are assumed homogeneous, respectively.
- There is no thermal contact resistance at any interface.
- The heat transfer mechanism in the grout and the ground formation is limited to conduction only and the presence of underground water flow is not considered.

By the foregoing assumptions, a full three-dimensional modeling was performed with the aid of commercial computational fluid dynamics software package, FLUENT. By taking the advantage of the symmetry of the geometry and heat transfer process, only half of the ground storage volume and its associated tubes, fluid, and grout are modeled (shown in Fig. 4). More detail about modeling can be found in [13].

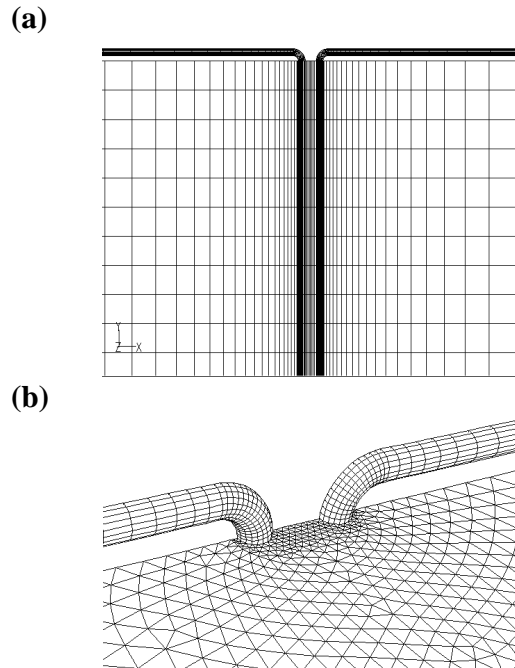

Fig.4 (a) Schematic of the computational grid in the symmetry plane of one borehole (b) Magnification of mesh neighboring to one borehole

IV. MODELING OF THE CCU

In this study, the famous $\epsilon - NTU$ method is used to model the CCU performance. A sensible cooling process, only exists when the outer surface temperature of the coil is equal to or higher than the dew point of the entering air. In the sensible cooling process, the humidity ratio is always constant. So, on a psychrometric chart it could be indicated by a horizontal line toward the saturation curve. Schematic diagram of the CCU is presented in Fig. 5.

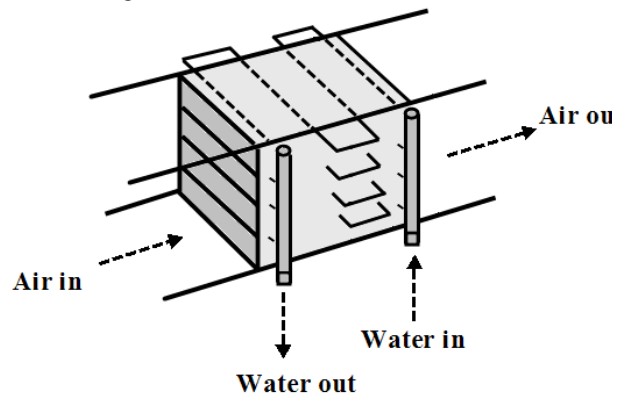

Fig. 5 Schematic of cooling coil unit

The overall heat transfer coefficient can be related to the inner and outer heat transfer coefficient by the following equation [16]:

$$\frac{1}{U} = R_f \frac{1}{h_a} + \frac{A_{out}}{A_{in}} \frac{d_{out}}{2K_p} \ln\left(\frac{d_{out}}{d_{in}}\right) + \frac{1}{h_w} \frac{A_{out}}{A_{in}} \quad (3)$$

where, A_{out} , A_{in} are the total outside and inside heat transfer area respectively, d_{out} and d_{in} are outer and inner tube diameter respectively, K_p is the pipe thermal conductivity, h_a is the air side heat transfer coefficient, and h_w is the water side heat transfer coefficient. The value of the heat transfer coefficients (h_w) for the waterside is calculated from Dittus-Boelter equation [17] and the value of heat transfer coefficients for the airside (h_a) is calculated from Zukauskas correlation [18].

Also R_f is the resistance of the fins at the airside, which is calculated from [16]:

$$R_f = \frac{A_{out} - (\eta A_{Fin} + A_p)}{A_{out}} \quad (4)$$

Where, η is the efficiency of the finned area, A_{Fin} is the total finned area, and A_p is the external area of tubes.

Also, the effectiveness of a CCU can be determined using the approach by Bejan [19] as:

$$\varepsilon_{CCU} = \frac{1 - \exp(-NTU(1-C))}{1 - C \exp(-NTU(1-C))} \quad (5)$$

Where, $NTU = \frac{UA}{C_{min}}$, $C = \frac{(\dot{m}C_p)_{min}}{(\dot{m}C_p)_{Max}}$ and \dot{m} is mass flow rate.

V. MODELING OF DEC

The direct evaporative cooling process works essentially based on the gradient exist in the humidity ratio which causes the evaporation of water. When water evaporates, it cools the surrounding air, therefore the necessary sensible heat is provided. For the mixture of air and water vapor, the heat transfer can be assumed adiabatic; a process along a constant wet bulb temperature on a psychrometric chart.

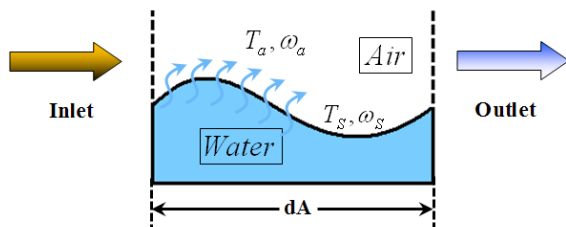

Fig. 6 Schematic of direct evaporation process

As shown in Fig. 6, based on the differences between surface temperature (T_s) and ambient air temperature (T_a) the convection heat transfer occurs. Also, from the humidity content gradient between surface (ω_s) and ambient air (ω_a) the mass transfer occurs. So the energy balance could be written as [20]:

$$\delta Q = \dot{m}_a di_a = [h_c(T_s - T_a) + K_D i_{vs}(\omega_{sw} - \omega_a)] dA \quad (6)$$

where, T_a is the ambient air temperature, ω_a the absolute humidity of air, ω_{sw} is the absolute humidity of wet surface, h_c is convective heat transfer coefficient, and K_D is the mass transfer coefficient. Using the specific enthalpy of the mixture and some mathematical procedures the output temperature of DEC can be calculated by:

$$\frac{(T_a)_{out} - T_s}{(T_a)_{in} - T_s} = \exp\left(-\frac{h_c A}{\dot{m}_s C_{pm}}\right) \quad (7)$$

It is assumed that the makeup water entering the sump to replace the evaporated water is at the same adiabatic saturation temperature of the incoming air. Dowdy and Karabash [20] introduced a correlation to establish the convective heat transfer coefficient in a rigid cellulose paper evaporative media:

$$Nu = 0.1 \left(\frac{l}{l_e}\right) Re_a^{0.8} Pr^{1/3} \quad (8)$$

Where, $l_e = V/A$ is the characteristic length in which V is the volume of evaporative pad, A is the total wetted surface area (area of the heat transfer surface), and l is the pad thickness. Reynolds and the Nusselt numbers are calculated using the characteristic length.

VI. EFFECTIVENESS

By fore going assumptions, the cooling effectiveness of a hybrid CCU and DEC system can be defined as:

$$\theta = \frac{(T_a)_{in} - (T_a)_{out}}{(T_a)_{in} - (T_{wb})_{in}} \quad (9)$$

Where, θ is the cooling effectiveness of the unit, $(T_a)_{in}$ and $(T_a)_{out}$ are the inlet and outlet dry bulb temperature of ambient air, respectively and $(T_{wb})_{in}$ is the inlet air wet-bulb temperature. It is important to bear in mind that the cooling effectiveness for a DEC system alone is lower than unity, but when the other supplementary systems are added to it, it may become greater than unity. It should be mentioned that, the cooling effectiveness is based on the temperature differences; and energy consumption of fluids transportation and other parameters are not considered in this definition.

VII. RESULTS AND DISCUSSION

In this study, Yazd and Kerman, two cities with arid weather condition in Iran, are chosen as a geographical location for examination of the thermal performance of the proposed hybrid system. It was noticed in these cities that, in some hot days during the summer, the DEC air conditioners could not bring comfort condition alone. Therefore, the system simulation has been performed at August 6th, at the middle of 2010 summer. Design parameters for these cities are shown in table I.

TABLE I
METEOROLOGICAL SPECIFICATIONS

PARAMETER/CITY	YAZD	KERMAN
Wet-bulb Temp (C)	21.3	20.5
Relative humidity (%)	14	13
Average Deep Ground Temperature	19.5	18.6

As can be seen in table I these two cities have arid weather condition and most of the time the DEC coolers in these cities face with lots of problems.

The cooling coil unit has aluminum fins with the staggered copper tubes. The water and air mass flow rate were chosen in the ways that were suitable for a small dwelling air conditioning. Also, other CCU specifications are presented in table 2. The theoretical modeling of the CCU has been verified in [13].

TABLE II
COOLING COIL UNIT SPECIFICATIONS

PARAMETER	VALUE
Height × Width (mm ²)	46×46
Number of rows of tubes	6
Number of tubes per row	12
Fin pitch (per meter)	394
Fin efficiency	0.935
Fin thickness (mm)	0.254
Vertical tube spacing (mm)	38.1
Horizontal tube spacing (mm)	30.5
Tube outside diameter (mm)	15.875
Tube wall thickness(mm)	0.508
Water flow rate (kg/s)	0.2
Air flow rate (m ³ /s)	0.472

After pre-cooling process, the cold ambient air enters to DEC pad with the same velocity. An evaporative pad with dimensions of $0.46 \times 0.46 \times 0.2m^3$ is considered. Note that the width and height of the pad are equal to the dimensions of the cooling coil. In other words, it is assumed that air passes through the same channel.

The GCC includes four vertical GHEs with the depth of 45 meters, which were arrayed in a series configuration. In order to achieve a maximum heat transfer coefficient inside the pipe, the mass flow rate was controlled and kept within the turbulent region. The contour of temperature around each borehole is shown in Fig. 7. It is seen that the warm water goes through the first borehole, rejects its heat to the ground and becomes colder and then goes to the next borehole. Eventually, the cold water exits from the last borehole and goes to the CCU. It is worthy to mention that foregoing method was applied to model the proposed GCC. Other specifications of the GCC are presented at Table 3.

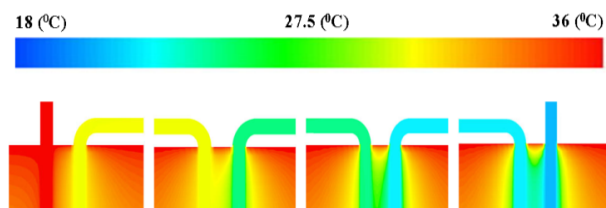

Fig. 7 Contour of temperature around each borehole

TABLE II
GROUND COUPLED CIRCUIT SPECIFICATIONS

PROPERTY	VALUE
Number of boreholes	4
Borehole depth (m)	45
Borehole diameter (cm)	22
Pipe diameter (mm)	32
Mean ground temperature (°C)	19
Center to center distance of boreholes (m)	4
Soil thermal conductivity (W/m K)	1.83
Soil density (kg m ⁻³)	2000
Soil specific heat capacity (J kg ⁻¹ K ⁻¹)	1400
Soil thermal diffusivity (m ² hr ⁻¹)	0.0035
Grout thermal conductivity (W/m K)	1.95
Grout density (kg m ⁻³)	2500
Grout specific heat capacity (J kg ⁻¹ K ⁻¹)	850
HDPE thermal conductivity (W/m K)	0.42
HDPE density (kg m ⁻³)	1100
HDPE specific heat capacity (J kg ⁻¹ K ⁻¹)	1465

As mentioned earlier, the hot water enters to the GCC and becomes cold. Then, the cold water enters to the CCU and interacts thermally with the ambient air stream: the ambient air is pre-cooled in the CCU. After this process, the pre-cooled air enters to the DEC. Simulation is performed for the most sever duration of a daytime - 9:00 AM to 17:00 PM - during which the cooling demand is the highest. The ambient air temperature at the exit of each section is presented in Fig. 8.

(a)

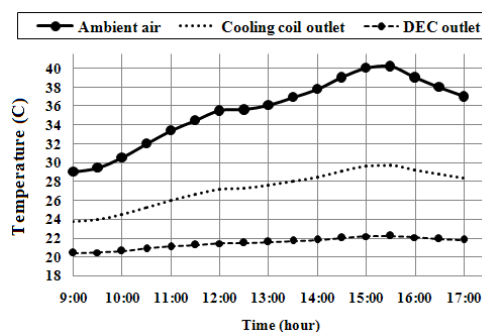

(b)

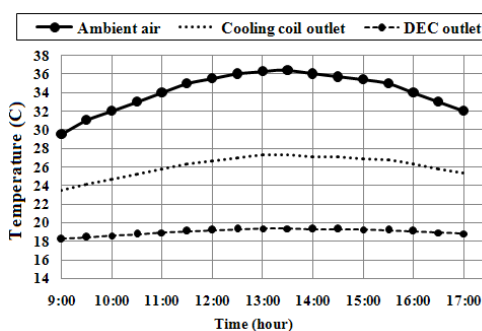

Fig. 8 Air temperatures at exit of each section (a) Yazd (b) Kerman

As seen in Fig. 8, the difference of the ambient air temperature between CCU inlet and outlet is about 7-8°C. Thus, the ambient air was entered to the DEC with a lower wet bulb temperature. This, pre-cooling process helped the DEC system to have a better performance in the regions that DEC alone may not work properly.

The effectiveness of the proposed system is greater than unity. For Yazd it is 1.05 and for Kerman it is 1.15. This means that the hybrid system could decrease air temperature below ambient wet-bulb temperature.

VIII.CONCLUSION

The behavior of a hybrid system of the ground heat exchangers, the cooling coil unit, and the direct evaporative cooling in Yazd and Kerman, two cities with arid weather condition in Iran, has been investigated. The cold water for the CCU is provided by the four vertical GHEs. Results show that in the regions where the direct evaporative coolers lonely cannot provide comfort conditions, the hybrid system has high potential to do that with a higher effectiveness. Taking advantage of ground as a renewable source of the passive cooling, the hybrid cooling system can be considered as an environmentally clean and energy efficient system. Thus, this system can be used as a replacement for mechanical vapor compression systems, leading to a decrease in the electrical energy consumption.

REFERENCES

- [1] V.C Mei, C.J Emerson, New approach for analysis of ground-coil design for applied heat pump system, ASHRAE Transaction 1985; 91: 1216–24.
- [2] N.K Muraya, D.L O’Neal, W.M Heffington Thermal interference of adjacent legs in vertical U-tube heat exchanger for a ground-coupled heat pump. ASHRAE Transaction 1996; 102: 12–21.
- [3] S.P Rottmayer, W.A Beckman, J.W Mitchell. Simulation of a single vertical U-tube ground heat exchanger in an infinite medium. ASHRAE Transaction 1997; 103: 651–59.
- [4] P. Cui, H. Yang, Z. Fang, Numerical analysis and experimental validation of heat transfer in ground heat exchangers in alternative operation modes. Energy and Buildings 2008; 40: 1060–66.
- [5] C.K Lee, H.N Lam, Computer simulation of borehole ground heat exchangers for geothermal heat pump systems. Renewable Energy 2008; 33: 1286–96.
- [6] Z. Li, M. Zheng, Development of a numerical model for the simulation of vertical U-tube ground heat exchangers. Applied Thermal Engineering 2009; 29: 920–24.
- [7] C. Yavuzturk, Modeling of Vertical Ground Loop Heat Exchangers for Ground Source Heat Pump Systems. Doctoral thesis, Oklahoma State University; 1999.
- [8] A. Gasparella, G.A Longo, R. Marra, Combination of ground source heat pumps with chemical dehumidification of air. Applied Thermal Engineering 2005; 25 (2–3): 295–308.
- [9] O. Ozgener, A. Hepbasli, An economical analysis on a solar greenhouse integrated solar assisted geothermal heat pump system. Journal of Energy Resources Technology 2006; 128(1): 28–34.
- [10] A.D Chiasson, C. Yavuzturk, Assessment of the viability of hybrid geothermal heat pump systems with solar thermal collectors. ASHRAE Transactions 2003; 109 (2): 487–500.
- [11] C.K Lee, H.N Lam, Computer simulation of ground-coupled liquid desiccant air conditioner for sub-tropical regions, International Journal of Thermal Sciences 2009; 48: 2365–74.
- [12] G. Heidarinejad, M. Bozorgmehr, S. Delfani, J. Esmacelian, Experimental investigation of two-stage indirect/direct evaporative cooling system in various climatic conditions. Building and Environment 2009; 44: 2073–79.
- [13] G. Heidarinejad, V. Khalajzadeh, S. Delfani, Performance analysis of a ground assisted direct evaporative cooling air conditioner, Building and Environment 45 (10) (2010) 2327–2335..
- [14] G Heidarinejad, M Heidarinejad, S. Delfani, J. Esmacelian, Feasibility of using various kinds of cooling systems in a multi-climates country. Energy and Buildings 2008; 40: 1946-53

- [15] T. Kusuda, P.R Archenbach, Earth temperature and thermal diffusivity at selected stations in the United States, ASHRAE Transaction 1965; 71(1):61-74.
- [16] S.K Wang, Handbook of air conditioning and refrigeration, Second edition, McGraw-Hill; 2001
- [17] P.W Dittus, L.M.K Boelter, Heat transfer in automobile radiators of the tubular type. Heat Mass Transfer 1985; 12: 3-22.
- [18] A.A Zukauskas, Heat transfer from tubes in cross Flow. Adv. Heat Transfer; 1972; 8: 93-160.
- [19] A. Bejan, Heat Transfer, Wiley; 1993.
- [20] J.A Dowdy, N.S Karabash, Experimental determination of heat and mass transfer coefficients in rigid impregnated cellulose evaporative media. ASHRAE Transaction 1987; 93 (Part 2): 382–395.