

Advanced ILQ Control for Buck-Converter via Two-Degrees of Freedom Servo-System

Sidshchadha Aumted, Shuhei Shiina, and Hiroshi Takami

Abstract—In this paper, we propose an advanced ILQ control for the buck-converter via two-degrees of freedom servo-system. Our presented strategy is based on Inverse Linear Quadratic (ILQ) servo-system controller without solving Riccati's equation directly. The optimal controller of the current and voltage control system is designed. The stability and robust control are analyzed. A conscious and persistent effort has been made to improve ILQ control via two-degrees of freedom guarantees the optimal gains on the basis of polynomial pole assignment, which our results of the proposed strategy shows that the advanced ILQ control can be controlled independently the step response and the disturbance response by appending a feed-forward compensator.

Keywords—Optimal voltage control, inverse LQ design method, second order polynomial, two-degrees of freedom.

I. INTRODUCTION

DUE to the buck DC-DC converter is used widely such as DC regulated power supply, photovoltaic system and DC motor regulated speed [1]. The sliding mode (SM) control technique is a possible option to control a DC-DC converters that must cope with their intrinsic nonlinearity, load variations, ensuring stability in any operating condition while providing fast transient response, and in addition to the traditional sliding mode control has the drawback of chattering phenomenon owing to its discrete control law [2], [3]. The optional of a practical servo-system on the basis of the optimal control theory is the inverse linear quadratic (ILQ) method, which finds the optimal gains to be based on the polynomial pole assignment without solving Riccati's equation [4]. With this method, it has the advantages of the transfer functions between inputs and outputs can be asymptotically designated for the desired specification, the optimal solutions are analytically obtained and guaranteed, and the optimal gains can be easily adjusted to obtain the desired responses at the point of use [5]-[7]. The optimal voltage control by 2nd-order polynomial is achieved through the suppression of resonant output voltage by improving ILQ method [8].

Therefore, this paper proposes the improved ILQ control via two-degrees of freedom which enables to controlled the independently step response and the disturbance response by

S. Aumted is with the Faculty of Engineering, Thai-Nichi Institute of Technology 1771/1 Pattanakarn Rd., Suanluang, Bangkok 10250, Thailand (phone: +662-763-2600 Ext. 2936; fax: +662-763-2600 Ext. 2900; e-mail: sidshchadhaa@tni.ac.th).

S. Shiina is with the Department of Electrical, Electronic and Information Systems Engineering, Shibaura Institute of Technology 3-7-5 Toyosu, Koto-ku, Tokyo 135-8548, Japan (e-mail: ma12048@shibaura-it.ac.jp).

H. Takami is with the Department of Electrical Engineering, Faculty of Engineering, Shibaura Institute of Technology 3-7-5 Toyosu, Koto-ku, Tokyo 135-8548, Japan (e-mail: takami@sic.shibaura-it.ac.jp).

appending a feed-forward compensator. This section describes the advantages of our designed method and provides a summary of some of our current simulation results for using the optimal controller of the current and voltage control system. Section II of this paper, we describe the design of our modeling and propose the designed control strategy. The ILQ control via two-degrees of freedom using in this paper is defined as 2D-ILQ. The proposed control system consists of modeling for the buck-converter circuit, solving the 2D-ILQ servo-system, and finding the basic gains, the optimal conditions and the solutions of the feed-forward compensator [4]-[7]. In particular, we demonstrate how to get the basic equations from our modeling for the buck-converter circuit, to solve the 2D-ILQ servo-system, to find the basic gains, the optimal condition in the 2D-ILQ servo-system and the solution of the feed-forward compensator. Section III, we present the numerical simulations and describe the resulting important properties of this design. And finally, we discuss related work and present the conclusion.

II. MODEL AND PROPOSED CONTROL STRATEGY

A. Modeling for the Buck-Converter Circuit

In this step, we have designed the buck-converter circuit with a resonant LC low-pass-filter for the voltage control, and derived its system equations.

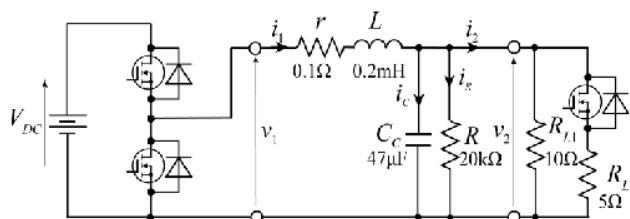

Fig. 1 The buck-converter circuit

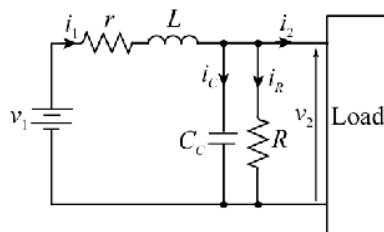

Fig. 2 Equivalent circuit of the buck-converter circuit

Fig. 1 represents the proposed buck-converter circuit, and Fig. 2 is a corresponding equivalent circuit which leads to two basis voltage equations and a basis equation of current. In this

circuit, the load composes of two resistors with switch, which gives the step-functional load test for the buck-converter circuit.

Thus, the basis equations are as follows:

$$v_1 = ri_1 + L \frac{d}{dt} i_1 + v_2, \quad v_2 = \frac{1}{C_C} \int i_C dt = Ri_R, \quad i_1 = i_C + i_R + i_2 \quad (1)$$

where L , C_C and R are inductance, capacitance and damping resistance of the passive low-pass filter, v_1 is a buck-converter output voltage, v_2 is a load voltage, i_1 is a buck-converter output current, i_2 is a load current, i_C is a current of capacitor C_C and i_R is a damping resistance current, respectively.

Considering the time-invariant system, a state equation can be obtained from (1) as follows:

$$\dot{x} = Ax + Bu + Dd, \quad y = Cx \quad (2)$$

where $\dot{x} = dx/dt$, $x = \begin{bmatrix} i_1 \\ v_2 \end{bmatrix}$, $u = v_1$, $d = i_2$

$$A = \begin{bmatrix} -\frac{r}{L} & -\frac{1}{L} \\ \frac{1}{C_C} & -\frac{1}{RC_C} \end{bmatrix}, \quad B = \begin{bmatrix} \frac{1}{L} \\ 0 \end{bmatrix}, \quad C = [0 \quad 1] \text{ and } D = \begin{bmatrix} 0 \\ -\frac{1}{C_C} \end{bmatrix}.$$

Henceforth, the plant must satisfy the conditions of the controllable and observable system, the minimal-phase system, and the no zeros at the origin, which already has all of conditions. Damping resistance R is usually large, so that we can neglect it and then we can verify and proof the system via the robust control theory approach [4], [5], [9].

B. How to Solve the 2D-ILQ Servo-System

In order to design the 2D-ILQ optimal servo-system, it needs to use four following principles [4], [7], [10], [11] as follows:

- 1) Our proposed strategy extended the state feedback system.
- 2) We can find the analytical optimal solution based on the ILQ design method.
- 3) We can get the asymptotic feature of the ILQ optimal servo-system.
- 4) We can follow the procedure for the optimal solutions of the 2D-ILQ servo-system.

In this moment, we first derive the basic construction for the 2D-ILQ servo-system, and then we explain about a procedure for getting the optimal solutions of the 2D-ILQ servo system.

C. Basic Construction of the 2D-ILQ Servo-System

Concerning the basic construction of the proposed 2D-ILQ servo-system, two additional feed-forward compensators $G_F(s)$ and $G_R(s)$ are improved the response of the reference input independently to the response of the disturbance, which are appended as shown in Fig.3, where y^* is a reference input, K_F is a state feedback gain, and K_I is an integral gain of the servo-controller.

Superposing the conventional ILQ servo-system of the

feed-forward compensators $G_F(s)$ and $G_R(s)$ are an effective procedure for finding out an optimal relation and then we have achieved the optimal solutions of the 2D-ILQ servo-system.

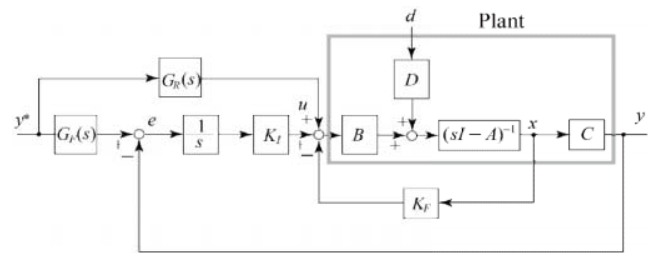

Fig. 3 Block diagram of the 2D-ILQ servo-system

In other words, the first we apply the ILQ solution procedures for conventional ILQ servo-system with the condition of $G_F(s)=1$ and $G_R(s)=0$ in Fig. 3, and the second we determine the $G_F(s)$ and $G_R(s)$ to the optimal gains 2D-ILQ servo-system by the response of y^* to y .

Considering the conventional ILQ servo-system with the gains K_F^0 and K_I^0 , the features of the responses are given by assigned poles, and the transfer functions become independent as $\Sigma \rightarrow \infty$ [4], [7] in Fig. 4.

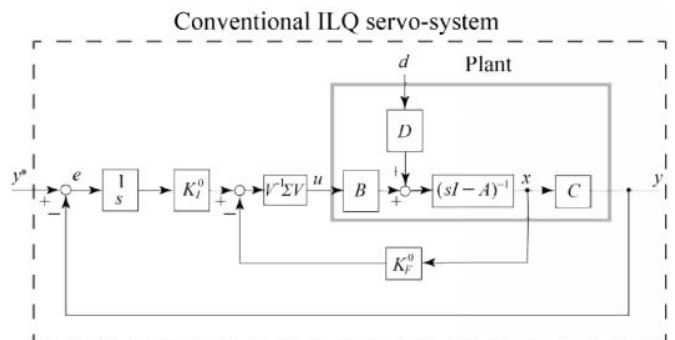

Fig. 4 Block diagram of the 2D-ILQ servo-system with $G_F(s)=1$ and $G_R(s)=0$

The basic gains are represented as

$$[K_F \quad K_I] = V^{-1} \Sigma V [K_F^0 \quad K_I^0] \quad (3)$$

where K_F^0 , K_I^0 are the basic optimal gains, $\Sigma > 0$ is a diagonal gain matrix as an adjusting parameter, and V is a suitable nonsingular matrix [6], [12], [13].

D. Finding the Optimal Gains and Conditions

The ILQ servo-system has the special features in which the closed-loop transfer functions converge to the objective decoupled-transfer functions. They lead to easy to adjust the gains and to control the servo-system.

The basic optimal gains K_F^0 and K_I^0 can be derived from the following procedures. The decoupling matrix is given as

$$D_c := c_1 A^{d_1-1} B \quad (4)$$

where D_c , which must be nonsingular, i.e. necessary-and-sufficient condition, enables to decouple the system, c_1 is the 1st row-vector of matrix C , and $d_1 = \min\{k|c_1 A^{k-1} B \neq 0, k=1,2,\dots\}$ is the order difference between the denominator and the numerator of the plant.

The order difference, $d_1 = 2$ in the system was given by (2). Hence, the stable polynomial for $\phi_1(s)$ determines the response of the servo-system in the condition $\Sigma \rightarrow \infty$, can be defined as

$$\phi_1(s) := \alpha_1 + \alpha_2 s + s^2 \quad (5)$$

where α_1 and α_2 are the coefficients of the polynomial, thus the objective transfer function is given by

$$G_1^\infty(s) = \frac{\phi_1(0)}{\phi_1(s)} = \frac{\alpha_1}{\alpha_1 + \alpha_2 s + s^2}. \quad (6)$$

A polynomial matrix can be defined as

$$N_\phi(A) := c_1 \phi_1(A) = c_1 (\alpha_1 + \alpha_2 A + A^2) = \begin{bmatrix} \alpha_2 - \omega_r^2 r & \alpha_1 - \omega_r^2 \end{bmatrix} \quad (7)$$

where $\omega_r = 1/\sqrt{LC_C}$ represents the resonant angular velocity of the passive second-order low-pass filter that composed of L and C_C .

We derive the decoupling gain as follows:

$$K = D_c^{-1} N_\phi(A) = \begin{bmatrix} \frac{1}{C_C} \frac{\alpha_2}{\omega_r^2} - r & \frac{\alpha_1}{\omega_r^2} - 1 \end{bmatrix} \quad (8)$$

Henceforth, we can obtain the optimal basic gains as follows:

$$\begin{bmatrix} K_F^0 & K_I^0 \end{bmatrix} = \begin{bmatrix} K & I \end{bmatrix} \begin{bmatrix} A & B \\ C & 0 \end{bmatrix}^{-1} = \begin{bmatrix} L & \frac{\alpha_2}{\omega_r^2} & \frac{\alpha_1}{\omega_r^2} \end{bmatrix}. \quad (9)$$

In order to achieve a simple design of the responses, we give the objective transfer function of (6) as

$$\alpha_1 := \omega_0^2, \quad \alpha_2 := 2\zeta_0 \omega_0 \quad (10)$$

where ω_0 is a natural angular velocity, and ζ_0 is a damping factor in its conventional ILQ servo-system.

According to reference [4], the optimal condition can be obtained as

$$\Sigma > 4\zeta \omega_n - 2/\tau \quad (11)$$

where $\tau = L/r$ is the time constant of the inductor.

Consequently, the transfer function from the reference y^* to

the output y is given by

$$G_1(s) = \frac{\Sigma \alpha_1}{s^3 + \Sigma s^2 + (\omega_r^2 + \Sigma \alpha_2) s + \Sigma \alpha_1}. \quad (12)$$

E. Finding the Solution of Feed-Forward Compensators

The 2D-ILQ servo-system can control independently the step response and the disturbance response by an additional feed-forward compensators that is concerned with the reference y^* in Fig. 5, representing the block diagram that appended the feed-forward compensators, which we can get the nonsingular basic gain of (9).

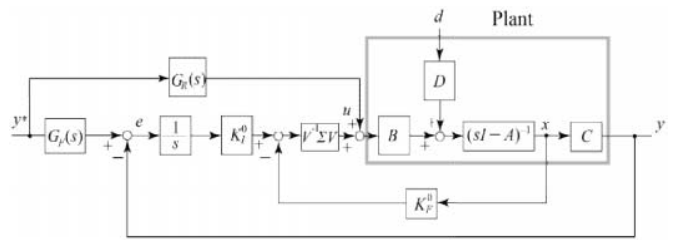

Fig. 5 Block diagram of the construction of the proposed 2D-ILQ servo-system

Equation (9) is concerned an equivalent block diagram with additional pre-filter as shown in Fig. 6, and its definition of (13) as follows:

$$G_C(s) = G_F(s) + s K_I^{0-1} V^{-1} \Sigma^{-1} V G_R(s). \quad (13)$$

We can redraw a simple block diagram of Fig. 6 from (12) and (13) as shown in Fig. 7. Thus, the total transfer function from y^* to y is derived from (12) and (13) as follows:

$$G_o^*(s) = \frac{\Sigma \alpha_1 \{G_F(s) + s K_I^{0-1} V^{-1} \Sigma^{-1} V G_R(s)\}}{s^3 + \Sigma s^2 + (\omega_r^2 + \Sigma \alpha_2) s + \Sigma \alpha_1}. \quad (14)$$

The order difference between the numerator and the denominator is second. Therefore, the objective transfer function is given by

$$G_o^*(s) = \frac{\omega_n^2}{s^2 + 2\zeta \omega_n s + \omega_n^2} \quad (15)$$

where ω_n and ζ are the target natural angular velocity and the damping factor of the 2D-ILQ servo-system, respectively.

From (14) and (15), the feed-forward transfer function is determined as

$$G_R(s) = \frac{\omega_n^2 s^2 + \Sigma (\omega_n^2 - \alpha_1) s + \omega_n (\omega_n \omega_r^2 + \omega_n \Sigma \alpha_2 - 2\zeta \Sigma \alpha_1)}{\omega_r^2 (s^2 + 2\zeta \omega_n s + \omega_n^2)}. \quad (16)$$

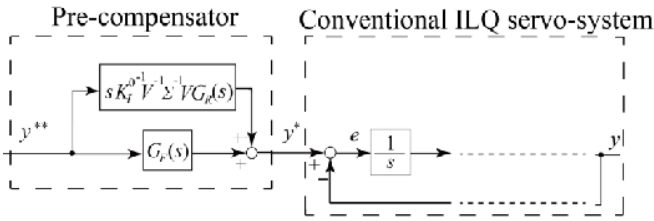

Fig. 6 Block diagram was placed the feed-forward compensator as the pre-compensator

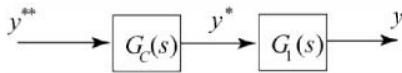

Fig. 7 Simple block diagram of Fig. 6

III. NUMERICAL SIMULATIONS AND RESULTS

All simulations, which were carried out at the condition of the DC input-voltage of 24V and the carrier frequency of 20kHz. The amplitudes of the reference voltage were varied from 9V to 12V at 10ms, and the step-functional load of 5Ω is connected to the output terminals at 15ms. The red line represents the reference voltage v_2^* and the actual voltage v_2 is represented by the blue line.

For the evaluating response by the reference input, we define a “rising time”, which is an interval from 10% to 90% of the output voltage. Moreover for the evaluating response by the disturbance of system, we define a “recovery time”, which is an interval from the impact of its disturbance to the recovering level of 90%.

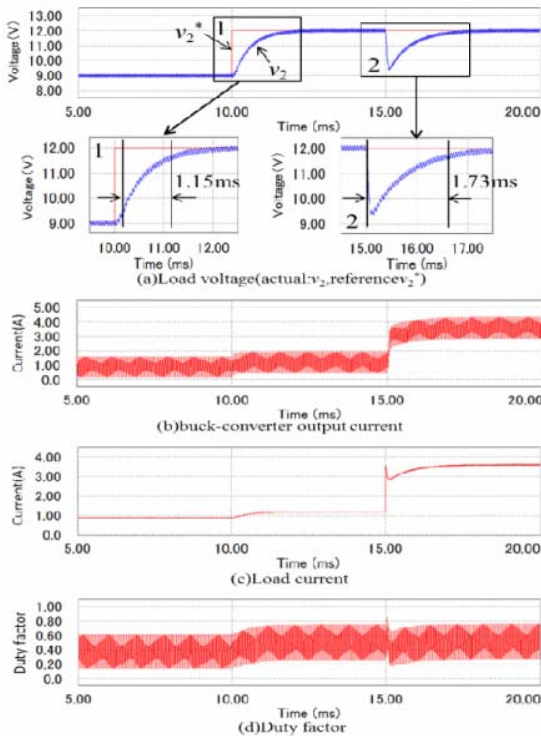

Fig. 8 Conventional ILQ control by 2nd-order polynomial $\alpha_1=5000^2, \alpha_2=2*1*5000, \sigma=40000, G_f(s)=1$ and $G_R(s)=0$

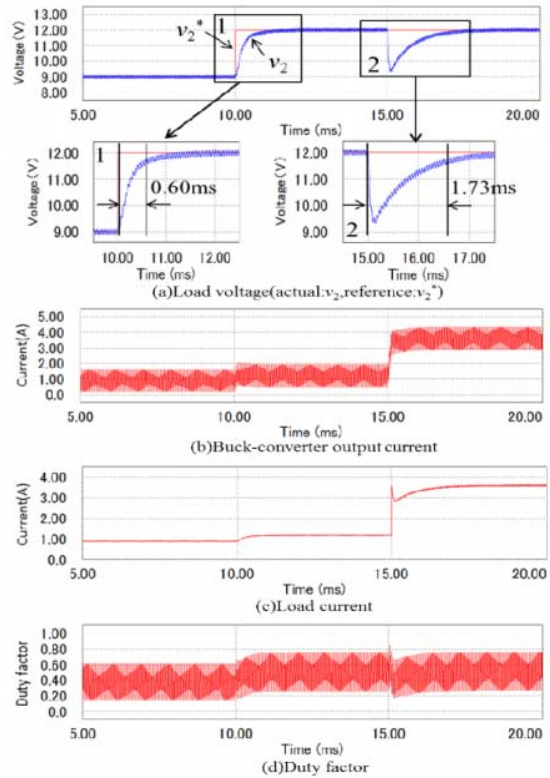

Fig. 10 Proposed 2D-ILQ control by 2nd-order polynomial $\alpha_1=5000^2, \alpha_2=2*1*5000, \sigma=40000,$

$$G_f(s)=1 \text{ and } G_R(s)=\frac{5.62s^2 + 1.25 \times 10^5 s + 1.35 \times 10^9}{1.06 \times 10^5 s^2 + 1.59 \times 10^5 s + 5.96 \times 10^8}$$

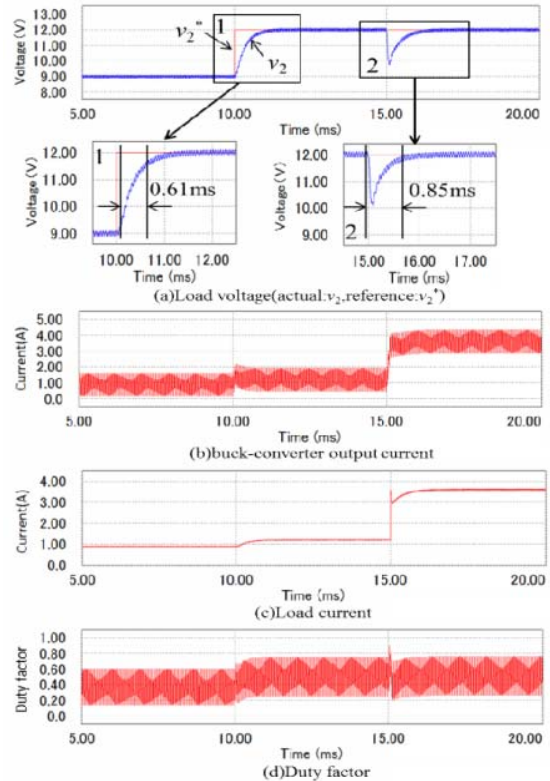

Fig. 9 Conventional ILQ control by 2nd-order polynomial $\alpha_1=7500^2, \alpha_2=2*1*7500, \sigma=40000, G_f(s)=1$ and $G_R(s)=0$

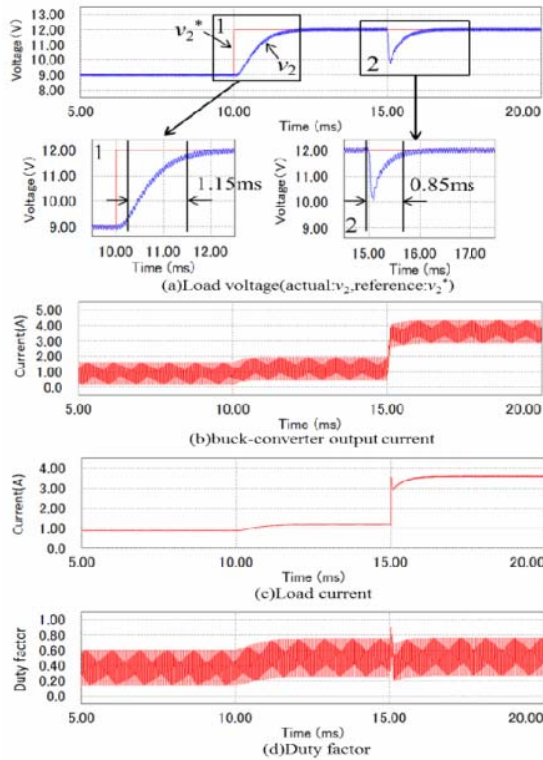

Fig. 11 Proposed 2D-ILQ control by 2nd-order polynomial
 $\alpha_1=7500^2, \alpha_2=2*1*7500, \sigma=40000,$
 $G_F(s) = \frac{2500}{s+2500}$ and $G_R(s)=0$

Fig. 8 and Fig. 9 show the waveforms of the conventional ILQ control when we changed the values of the factors α_1 and α_2 due to (10) with the 2nd-order polynomial while the waveforms of the proposed 2D-ILQ control are shown as in Fig. 10 and Fig. 11. The rising times and the recovery times of all are summarized in Table I.

As the simulation result in Fig. 10, the rising time of the proposed 2D-ILQ control is 0.60ms that is faster than the rising time of the conventional ILQ control is 1.15ms as shown in Fig. 8 while the recovery times of all are corresponded to 1.73ms. This case shows that the rising time is able to adjust via $G_R(s)$ for changing the speed response, whereas the recovery time is unaffected by $G_R(s)$.

Likewise, the rising time is 1.15ms as shown in Fig. 11, is slower than the rising time as shown in Fig. 9 is 0.61ms while the recovery times of all are corresponded to 0.85ms. This case shows that the rising time is also able to adjust via $G_F(s)$ for changing the speed response, whereas the recovery time is also unaffected by $G_F(s)$.

Consequently, the additional feed-forward compensators $G_F(s)$ and $G_R(s)$ are improved the response of the reference input independently to the response of the disturbance, which are appended as shown in Fig. 3 and concerned with (13) and (16).

Considering the simulation result in Fig. 10, the recovery time of the proposed 2D-ILQ control is 1.73ms that is longer than the recovery time of the conventional ILQ control is 0.85ms as shown in Fig. 9 while the rising times of all are

corresponded to 0.6ms.

Likewise, the recovery time is 0.85ms as shown in Fig. 11, is shorter than the recovery time as shown in Fig. 8 is 1.73ms while the rising times of all are corresponded to 1.15ms.

This case shows that the recovery times is able to adjust via ω_h for changing the speed response, whereas the rising time is unaffected by ω_h under the condition of $G_F(s)$ and $G_R(s)$ are not equal to zero.

TABLE I
 RISING TIME AND DECLINE OF DISTURBANCE IN EACH CONTROL STRATEGY

	Conditions	Rising Time	Recovery Time
Fig. 8 (a)	Conventional ILQ control by 2 nd -order polynomial $\omega_0=5000, \sigma=40000$ $G_F(s)=1, G_R(s)=0$	1.15ms	1.73ms
Fig. 9 (a)	Conventional ILQ control by 2 nd -order polynomial $\omega_0=7500, \sigma=40000$ $G_F(s)=1, G_R(s)=0$	0.61ms	0.85ms
Fig. 10 (a)	Proposed 2D-ILQ control by 2 nd -order polynomial $\omega_0=5000, \omega_h=7500, \sigma=40000,$ $G_F(s)=1,$ $G_R(s) = \frac{5.62s^2 + 1.25 \times 10^5 s + 1.35 \times 10^9}{1.06 \times 10^8 s^2 + 1.59 \times 10^5 s + 5.96 \times 10^8}$	0.60ms	1.73ms
Fig. 11 (a)	Proposed 2D-ILQ control by 2 nd -order polynomial $\omega_0=7500, \sigma=40000,$ $G_F(s) = \frac{2500}{s+2500}, G_R(s)=0$	1.15ms	0.85ms

σ =gain adjusting parameter

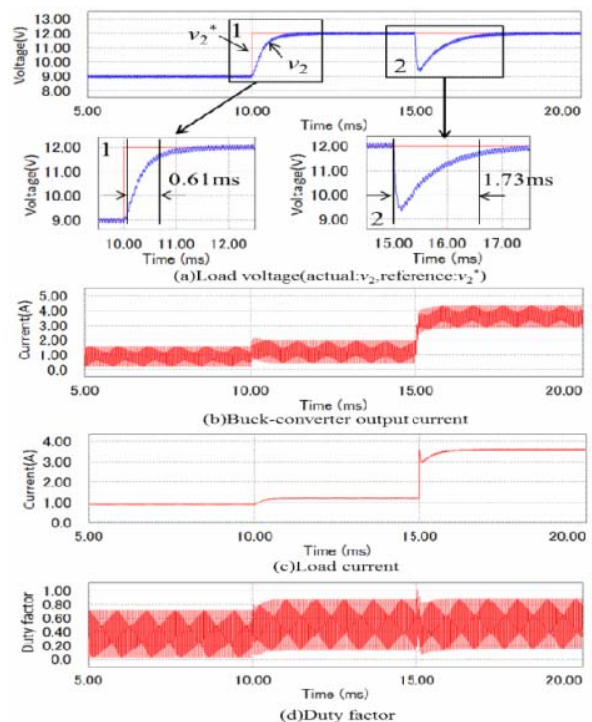

Fig. 12 Responses to 100% error of L in Fig. 10

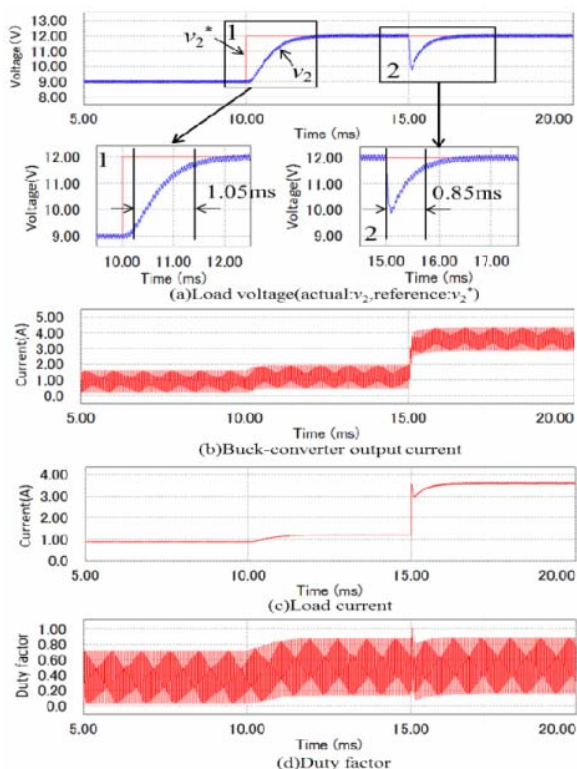

Fig. 13 Responses to 100% error of L in Fig. 11

The results in Fig. 12 and Fig. 13 show the results of simulations, which were carried out at the condition with parameter errors in Fig. 10 and Fig. 11, respectively. The inductance, which is one of the key parameters and determines the performance of the buck-converter circuit, is changed at values two times as its nominal value. Compared Fig. 10 (a) with Fig. 12 (a), and then Fig. 11 (a) with Fig. 13 (a), we found that the rising times and the recovery times are almost the same as each other, so that we can verify that proposed control strategy makes the robust buck converter although the converter parameters are varied.

From Fig. 8 (b), Fig. 9 (b), Fig. 10 (b), Fig. 11 (b), Fig. 12 (b) and Fig. 13 (b), the buck converter output current in all systems can be controlled by the ILQ control method, and used to the current feedback part for our strategy. In the proposed 2D-ILQ control of Fig. 10 (c), Fig. 11 (c), Fig. 12 (c) and Fig. 13 (c), and the conventional ILQ control of Fig. 8 (c) and Fig. 9 (c), after the step-functional load of 5Ω is connected to the output terminals at 15ms, the peak value of the output current load is affected to correlate with the output voltage in the region 2 of each figure. That has the least significance for controlling overall system because the voltage converges to the reference voltage at a short amount of time. At last in Fig. 8 (d), Fig. 9 (d), Fig. 10 (d), Fig. 11 (d), Fig. 12 (d) and Fig. 13 (d), the duty factor of all cases fall in the region of $(0,1)$ are under control.

IV. CONCLUSION

In this paper, we have proposed an advanced ILQ control (2D-ILQ control) for the buck-converter via two-degrees of freedom servo-system based on the conventional

ILQservo-system. The 2D-ILQ control can be controlled independently the step response and the disturbance response by appending a feed-forward compensators. However, the disturbance response must be suppressed in the practical servo-system.

REFERENCES

- [1] F. Hsieh, N. Yen, and Y. Juang, "Optimal controller of a buck DC-DC converter using the uncertain load as stochastic noise," *IEEE Transactions on Circuits and Systems II: Express Brief*, vol. 5, pp. 77- 81, Feb. 2005.
- [2] M. Bensaada, A. Stambouli, M. Bekhti, S. Krachai, L. Boukhris, A. Bellar, M. Mebrek, and B. Nasri, "Sliding mode controller for buck DC-DC Converter. Systems, Signals and Devices (SSD)," in *Proc.9th International Multi-Conference, Chemnitz*, 2012, pp. 1-6.
- [3] H. Yigeng, M. Ruiqing, X. En, and A. Miraoui, "A robust second order sliding mode controller for Buck converter," *International Conference Electrical Machines and Systems (ICEMS)*, Incheon, 2010, pp. 159-161.
- [4] T. Fujii, "A New Approach to the LQ Design from the Viewpoint of the Inverse Regulator Problem," *IEEE Trans. Automatic Control*, vol. AC-32, no. 11, pp. 995-1004, Nov 1987.
- [5] T. Fujii, Y. Nishimura, S. Shimomura, and S.Kawarabayashi, "A Practical Approach to LQ Design and Its Application to Engine Control," in *Proc. IFAC'87*, Munich, 1987, pp. 253-258.
- [6] H. Kimura, T. Fujii, and T. Mori, *Robust Control*. Tokyo: Corona Publishing Co., Ltd, 1994, pp. 109-156.
- [7] H. Takami, "Robust Current Control for Permanent Magnet Synchronous Motors by the Inverse LQ Method -An Evaluation of Control Performance Using Servo-Locks at Low Speed-," *Journal of power Electronics*, vol. 4, no.4, pp. 228-236, Oct. 2004.
- [8] S. Aumted, S. Kanda, H. Takami, and S. Tatsuno, "Optimal Voltage Control for Single-Phase Inverter with Resonant LC Filter by Type-2 ILQ Servo-Control by 2nd-Order Polynomial," in *Applied Mechanics and Materials Journal:Trans Tech Publications*, Switzerland, 2013, vol. 622-623, pp. 1514-1518 [ICMCE 2012 Conf. Shanghai, Aug. 2012].
- [9] T. Fujii, S. Kunimatsu, and O. Kaneko, "Synthesis of ILQ Control System for Disturbance Attenuation," in *Proc. SICE Annual Conference*, Japan, 2008, pp. 1300-1303.
- [10] T. Fujii, and T. Shimomura, "Generalization of ILQ Method for the Design of Optimal Servo Systems," *Trans. of the Institute of Systems, Control and Information Eng.* vol. 1, no. 6, pp.194-203, 1988.
- [11] T. Shimomura, T. Fujii, and N. suda, "Generalization of the ILQ Regulator Design Method," in *Proc. American Control Conference*, Seattle, 1995, pp. 1967-1968.
- [12] T. Fujii, "Design of Tracking Systems with LQ Optimality and Quadratic Stability," in *Proc. IFAC World Congress, IFAC'93*, Sydney, 1993, pp. 435-442.
- [13] H. Takami, "Design of an optimal servo-controller for current control in a permanent magnet synchronous motor," in *Proc. IEE -Control Theory and Applications*, vol. 149, no. 6, pp. 564-572, Nov. 2002.

Sidshchadhaa Aumted was born in Phayao, Thailand, on April 6, 1979. She received the B.Eng. degree in Electrical Engineering from Rajamangala Institute of Technology, Pathum Thani, Thailand and The M.S. degree in Computer Science from Kasetsart University, Bangkok Thailand, in 2001 and 2007, respectively.

From 2007 to 2009, she was a lecturer at Kasetsart University Si Racha Campus with the Department of Computer Science, Faculty of Resource and Environment, Chonburi Thailand. Since 2010, she has been associated with the Faculty of Engineering (Computer Engineering), Thai-Nichi Institute of Technology, Bangkok Thailand, where she has been a lecturer. From December 2011 to June 2012, she was a visiting scholar at Shibaura Institute of Technology, Tokyo Japan, and did research on the optimal voltage control for single-phase inverter with resonant LC filter via type-2 ILQ servo-control by 2nd-order polynomial for six months. She has been active in the fields of wireless communication, embedded system and power electronics. Her present research is concerned with ILQ optimal control system.

Ms. Aumted was a member of Electrical Engineering/Electronics, Computer, Telecommunications and Information Technology Association of Thailand (ECTI Thailand).

Shuhei Shiina was born in Yamagata, Japan, on June 29, 1989. He received the B.E. degree in Mechanical engineering from the Tokyo Denki University, Saitama Japan in 2012.

Since 2012, he has been with the Department of Electrical, Electronic and Information Systems Engineering, Shibaura Institute of Technology. His present research is concerned with ILQ control for buck converter.

Hiroshi Takami was born in Oita, Japan, on September 21, 1960. He received the B.E. degree in Electrical Engineering from the Kyushu Institute of Technology in 1983 and the M.E. degree in Electrical Engineering from Kyushu University in 1985. He also received the Dr. Eng. degree in Electrical Engineering from Kyushu University in 1992.

From 1985 to 1993, he was with the Department of Electrical Engineering, Yamaguchi University, where he was an Assistant. Then he was a Research Associate with the Department of Electrical Engineering, Kyushu University from 1993 to 2005. Since 2005, he was Associate Professor with the Department of Electrical Engineering, Faculty of Engineering, Shibaura Institute of Technology, Tokyo Japan until he has been a Professor in 2008. He is engaged in the development of the optimal control for power electric systems and motors, renewal energy generation system and smart community project.

Prof. Dr. Takami is a member of the Institute of Electrical Engineers of Japan, the Society of Instrument and Control Engineers of Japan and the Institute of Electrical and Electronic Engineers of USA (IEEE USA).