

Meandered Microstrip Open Circuited Stub with Bandstop Characteristic

Goh Chin Hock, Chandan Kumar Chakrabarty, Mohammad Hadi Badjian, and Sanjay Devkumar

Abstract—This paper presents a microstrip meandered open circuited stub with bandstop characteristic. The proposed structure is designed on a high frequency laminate with dielectric constant of 4.0 and board thickness of 0.508 millimeters. The scattering parameters and electromagnetic field distributions at various frequencies are investigated by modeling the structure with three dimensional electromagnetic simulation tool. In order to describe the resonant and bandstop characteristic of the meandered open circuited stub, a Smith chart as well as electric field at various frequencies and phases is illustrated accordingly. The structure can be an alternative method in suppressing the harmonic response of a bandpass filter.

Keywords—Bandstop, Equivalent Lumped Element Model, Electromagnetic Model, Meandered Open Circuited Stub

I. INTRODUCTION

MODERN wireless communication system has evolved rapidly and gives rise to the dramatic demand for lower cost products and higher communication capacity. However, the electromagnetic spectrum is limited and has to be shared. Consequently, microstrip filter play an essential role in supporting the technology growth. In general, microstrip can be used to design a low cost microwave filter as the development processes and materials are relatively economical. With the enhancement in filter technology, various structures have been developed in order to enhance the frequency response. Stepped impedance [1], interdigital [2] and spiral [3] structure have already shown the capability in improving spurious response of a resonator. Equivalent circuit models for such structures are commonly used in order to describe and analyze their electrical behavior. The adopted structure has greatly enhanced the effective capacitance and inductance for the response enhancement. On top of that, advanced computer simulation tools have emerged during the recent years in order to solve problems of unprecedented electromagnetic (EM) field complexities. As an essential component of engineering and scientific research, three dimensional EM simulators are commonly used for accurate evaluation of single and multilayer microwave filters.

Goh Chin Hock, Chandan Kumar Chakrabarty, Sanjay Devkumar and Mohammad Hadi Badjian are with the Department of Electronics and Communication, College of Engineering, Universiti Tenaga Nasional, Selangor, Malaysia (Office: 603-8921-2020 ext:3288 and 2340 ; fax:603-89212116; email: chinhock@uniten.edu.my, chandan@uniten.edu.my, sanjay@uniten.edu.my, mhadi@uniten.edu.my).

In this paper, a meandered microstrip open circuited stub with bandstop characteristic is presented. As a defected structure which realized by etching a gap on a microstrip line, spurline [5-8] could increase fabrication constraints and for this reason production repeatability is difficult to be maintained. Hence, the proposed structure can be used as alternative method to suppress the second harmonics of a bandpass filter. The presented structure has the advantages of simplicity in cascading and fabrication. Furthermore, the structure needs no additional fabrication processes and circuit elements such as capacitor, inductor and via hole. Hence, low fabrication cost of a microstrip resonator can be retained as reported spurline and spiral resonator. The meandered open circuited stub is investigated with three dimensional EM simulators. A basic equivalent circuit model and Smith chart is used in order to describe the resonant and bandstop characteristic of the structure.

II. CHARACTERISTIC AND MODELING OF MEANDERED STUB

The physical layout of a proposed meandered open circuited stub with bandstop characteristic is illustrated in Fig. 1. The basic dimension of the proposed structure is represented by three important primary parameters. They are gap S , width W , and length L . In general, the gap of a transmission line exhibits capacitive effect [9] while the width can be used to provide inductive effect [10]. As electric fields exist across the gap of a transmission line, capacitive reactance of the line is increasing with respect to dimension of the gap. This capacitive reactance can be represented as a lumped capacitor C_g , located at the plane A-A' as presented in Fig. 1. In designing the proposed meandered open circuited stub, microstrip technology is implemented. The representative views of the two dimensional electric field distributions at frequency 5 GHz and phase of zero degree are given in Fig. 2. In order to visualize the electric field distributions on some cross section, the cut-plane that aligns with axis X is adjusted accordingly. It is clear from Fig. 2 that microstrip is inhomogeneous as the fields in the microstrip extend within two media, dielectric below and air above. Due to this nature, the microstrip [11] does not support a pure transverse electromagnetic wave, making the structure dispersive. Fig. 2(a) shows the electric coupling exits between the straight microstrip line and open end of the proposed stub. Hence, the graphical representation of the electric field confirms the hypothesis about the equivalent lumped element of the gap.

A meandered open circuited stub is design on a high frequency laminate with dielectric constant of 4.0 and board thickness of 0.508 millimeters. A three dimensional electromagnetic simulation tool is used in order to analysis and model the proposed meandered open circuited stub. The EM behavior of the structure is obtained by simulating the structure in the frequency range of 1 GHz to 15 GHz. As shown in Fig. 3(a), the proposed meandered open circuited stub with the physical length L , of 9.5 millimeters is resonates at the frequency of 7.06 GHz. From the simulation results, S_{21} and S_{11} with the magnitude of -51.95 dB and -0.01826 dB are achieved respectively. Fig. 3(b) shows the scattering parameter phase in degrees of the proposed structure. From the simulation results, S_{21} and S_{11} with the phase of 5.894° and 167.3° are obtained respectively.

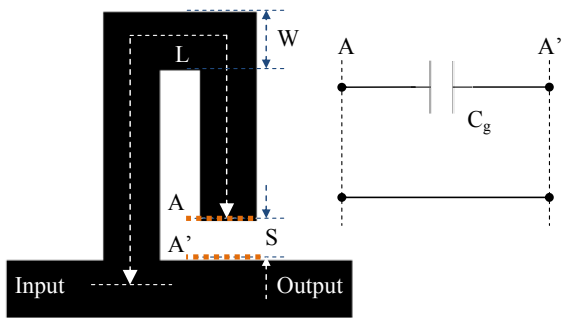
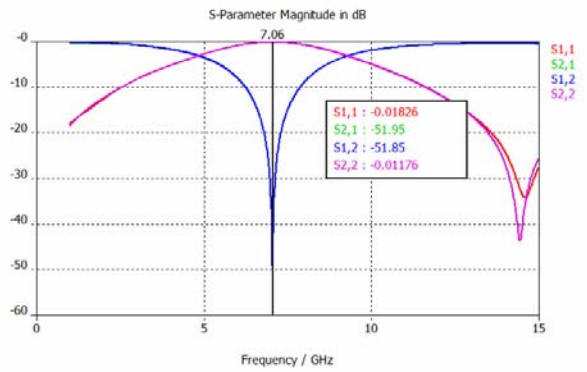
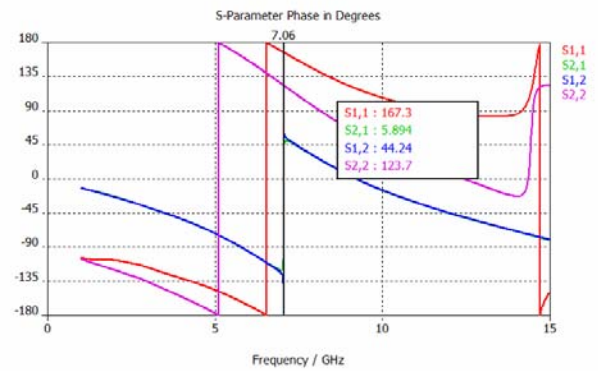

Fig. 1 Physical Layout of the Proposed Meandered Shunt Open Circuited Stub and Equivalent Circuit Model of the Gap



(a)



(b)

Fig. 3 Scattering Parameter Simulation Results of the Proposed Meandered Open Circuited Stub with Physical Length L , of 9 Millimeters (a) Magnitude (b) Phase

In addition to operating frequency of 7.06 GHz, simulation results at 2.06 GHz and 9.06 GHz are investigated also. As shown in the Fig. 3(a), S_{21} with the magnitude of -0.2615 dB and -3.63 dB is achieved respectively for the frequencies under study. Fig. 4, 5 and 6 illustrates the magnetic field of the bandstop resonator at phase of 210° . It is clear from Fig. 4 and Fig. 5 that the structure is resonate at 7.06 GHz while have relative low return loss at 2.06 GHz.

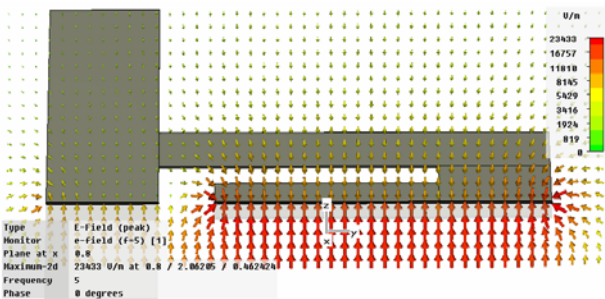

(a)

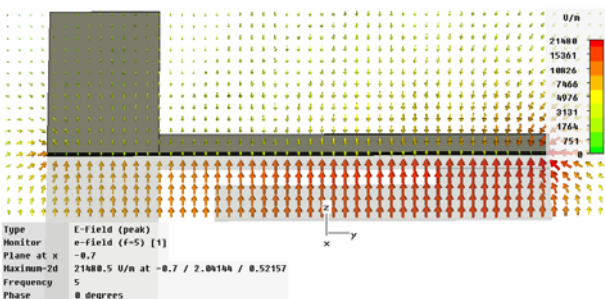

(b)

Fig. 2 Representative View of the Two Dimensional Electrical Field Distributions at Frequency of 5 GHz and Phase of 0 Degree (a) Electric Field at $X = 0.8$ (b) Electric Field at $X = -0.7$

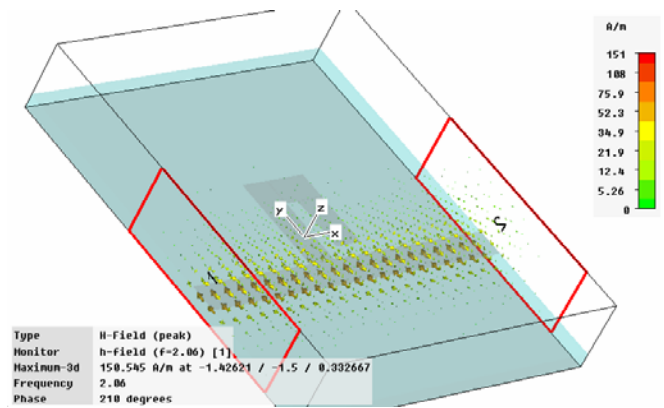

Fig. 4 Vector Plot Magnetic Field Distribution of the Proposed Structure at 2.06 GHz

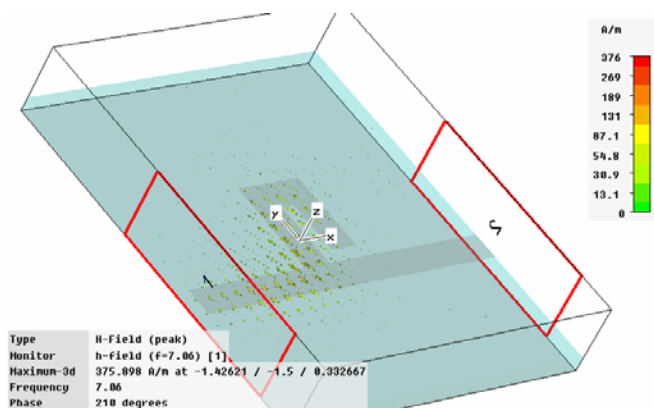

Fig. 5 Vector Plot Magnetic Field Distribution of the Proposed Structure at 7.06 GHz

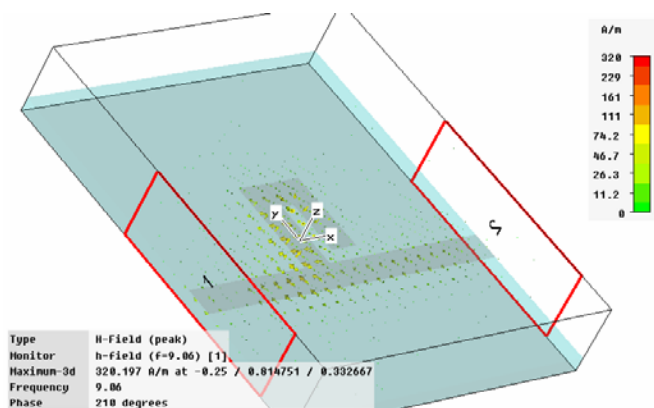

Fig. 6 Vector Plot Magnetic Field Distribution of the Proposed Structure at 7.06 GHz

III. SMITH CHART AND DISCUSSION

The use of the Smith chart avoids the tedious computational as the calculations normally involve complex numbers and time consuming. Smith chart is the graphical representation of the impedance transformation property with respect to the length and operating frequency of the designed structure. Consequently, the inductive and capacitive impedances which were generated by a structure can be illustrated directly at the investigated operating frequency. As shown in the Fig. 7, the S_{21} of the proposed structure at the frequency of 7.06 GHz is generally plotted at the centre of the polar plot. From the polar plot, it is generally no signal transmitted from port 1 to port 2 at resonant frequency. In contrast, the insertion loss of the structure is decreased at lower and higher frequency as indicated by the curve in Fig. 7. Fig. 8 shows the reflection coefficient S_{11} of the proposed structure. In general, at resonant the inductive reactance and the capacitive reactance become equal and opposite in sign [12]. However, the overall reactance of the presented structure is not zero as shown in Fig. 8 as additional length of microstrip have been taken account into the simulation. By reducing the length of the feeding length, reactance of the overall structure can be reduce and close to pure resistive. As comparable to open circuited

stub, conventional spurline and meandered spurline, the proposed structure can be modeled as parallel resonance LC circuit [13-15]. A basic equivalent lumped element circuit as shown in Fig. 9 can be used to represent the characteristic of the meandered open circuited stub and the additional microstrip feeding line.

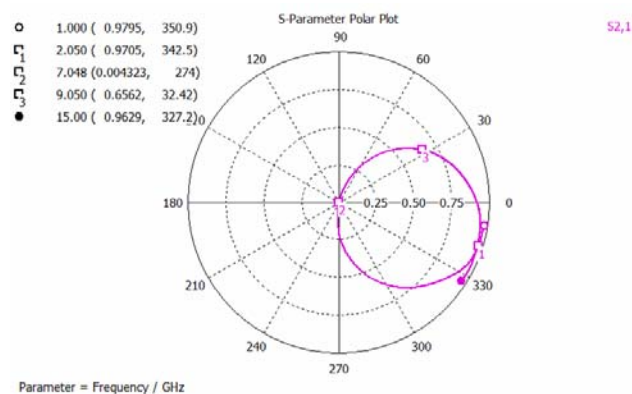

Fig. 7 Polar Plot of the S_{21} of the Meandered Open Circuited Stub

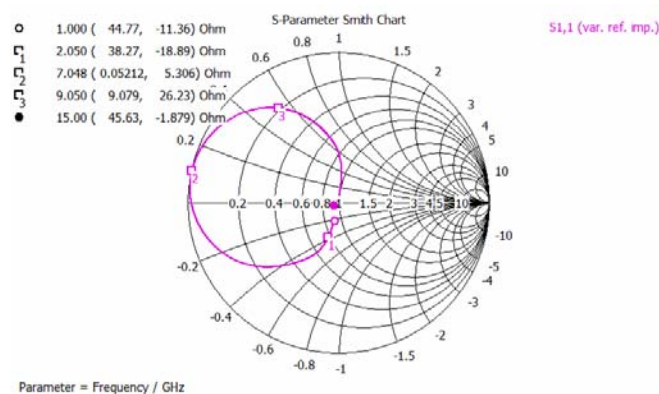

Fig. 8 Smith Chart view of S_{11} of the Meandered Open Circuited Stub

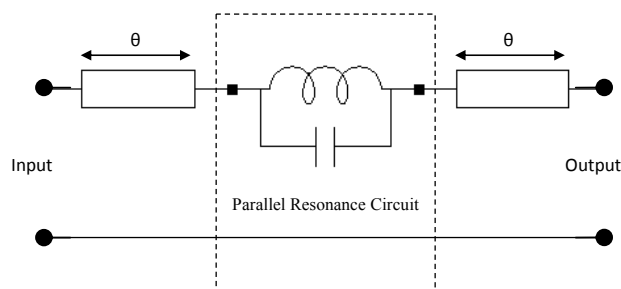

Fig. 9 Basic Equivalent Lumped Circuit Element for the Overall Proposed Structure

For a lossless transmission line, the input impedance and reflection coefficient are given as in (1) and (2) [16-17]. Hence the scattering parameter S_{11} , can be expressed in term of input impedance as in (2) [18].

$$Z_{in} = Z_0 \left(\frac{Z_L + jZ_0 \tan \beta l}{Z_0 + jZ_L \tan \beta l} \right) \quad (1)$$

$$\Gamma = \frac{Z_L - Z_0}{Z_L + Z_0} \quad (2)$$

$$S_{11} = \frac{Z_{in} - Z_0}{Z_{in} + Z_0} \quad (3)$$

De-embedding techniques is employed in order to reduce the additional length. Fig. 10 shows the meandered open circuited stub is resonate at about 0.25λ or electrical length of 90 degree. Besides, representative view of electric field as shown in Fig. 11 validates the structure resonates at 0.25λ .

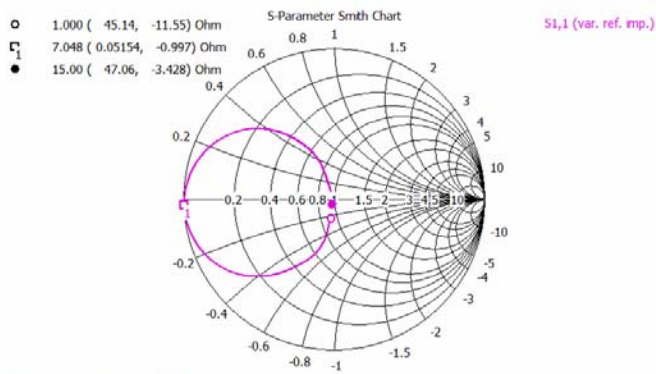
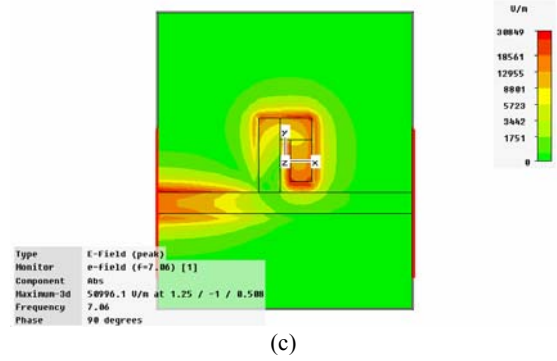
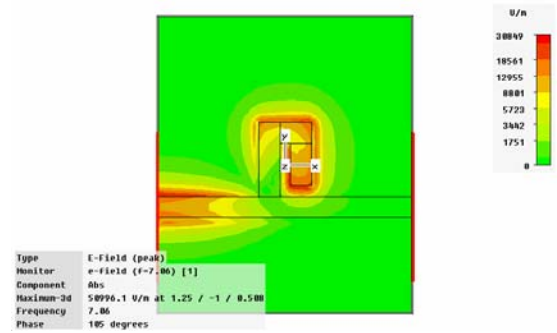

Fig. 10 Smith Chart view of S_{11} of the Meandered Open Circuited Stub using De-embedding Technique



(c)



(d)

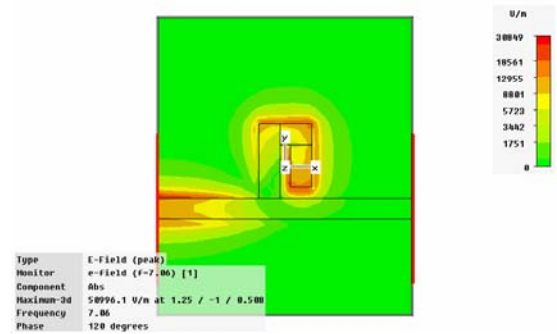

(e)

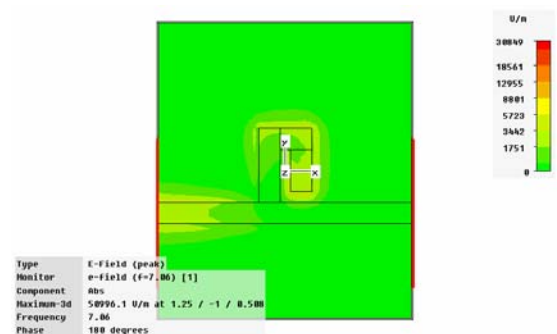

(f)

Fig. 10 Representative View of Electric Field (a) 15° (b) 45° (c) 90° (d) 105° (e) 120° (f) 180°

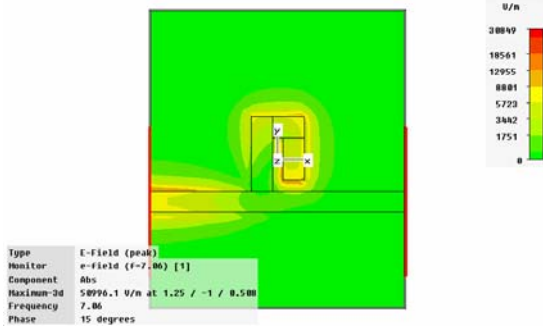

(a)

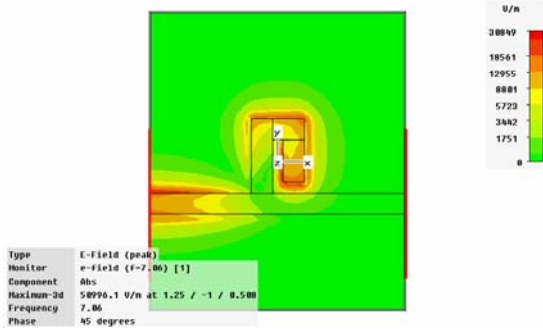

(b)

IV. CONCLUSION

A meandered open circuited stub has been investigated at resonant condition as well at lower and higher frequency. As comparable to conventional open stub and spurline structure, the structure can be used to suppress the harmonic signal for the bandpass filters. Besides that, it has less radiation loss as compared to the straight open circuited stub. The advancement of the simulation tool has reduced the design latency as faced by designer as many of the design methodology can be simplified. By using the analytical and synthesis formulas as the guidelines, a quick development and tap out is possible.

ACKNOWLEDGMENT

The work at Uniten is financially supported by eScience Fund, Grant No. 03-02-03-SF0074.

REFERENCES

- [1] Y. Z. Wang and M. L. Her, "Compact microstrip bandstop filters using stepped-impedance resonator and spur-line sections," IEE Proceedings microwaves, antennas and propagation, vol. 153, issue 5, Oct., pp. 435-440, 2006.
- [2] R. Y. Yang, M. H. Weng, C. Y. Hung, H. J. Chen, and M. P. Houg, "Novel compact microstrip interdigital bandstop filters," IEEE Trans. on Ultrasonics, Ferroelectrics and Frequency Control, vol. 51, issue 8, Aug., pp. 1022 – 1025, 2004.
- [3] Joubert, J, "Spiral microstrip resonators for narrow-stopband filters," IEE Proceedings Microwaves, Antennas and Propagation, vol. 150, issue 6, Dec., pp. 493 – 496, 2003.
- [4] B. M. Schiffman and G. L. Matthaei, "Exact design of bandstop microwave filters," IEEE Trans. Microwave Theory Tech., vol. MTT-12, pp. 6-15, Jan. 1964.
- [5] R. N. Bates, "Design of microstrip spurline bandstop," IEE J. Microwaves, Optics and Acoustics, vol. 1, no. 6, pp. 209-214, Nov. 1977.
- [6] C. Nguyen, C. Hsieh and D. W. Ball, "Millimeter wave printed circuit spurline filters," IEEE MTT-S Int. Microwave Symposium Dig., pp98-200, 1983.
- [7] Preeti Sharma, Shiban K.Koul and Sudhir Chandra, "Micromachined spurline bandstop filter." IEEE Int. Workshop on RFIT, Dec 9-11, 2007.
- [8] K. C. Gupta, R. Garp, I. Bahl, and P. Bhartia, Microstrip lines and slotlines, 2nd Edition, Artech House, Dedham, MA, pp. 127-138, 1996
- [9] K. Chang, I. Bahl and Vijay Nair, Rf and microwave circuit and component design for wireless systems, John Wiley & Sons, LTD, pp 146-164, 2002.
- [10] Joseph F. White, High frequency techniques, an introduction to rf and microwave engineering, IEEE Press, pp. 78-115, 2004
- [11] Jon B. Hagen, Rf Electronics, circuits and applications, Cambridge University Press, pp 4-5, 1996
- [12] C. Nguyen and K. Chang, "On the analysis and design of spurline bandstop filters," IEEE Trans. on Microwave Theory and Tech., Vol. 33, No. 12, Dec., pp. 1416–1421, 1985
- [13] W. H. Tu and K. Chang, "Compact microstrip bandstop filter using open stub and spurline," IEEE Microwave Wireless Component Letter, vol.42, no.13, Jun, pp.762-763, 2006.
- [14] Haiwen Liu, Reinhard H. Knoechel, and Klau F. Schuenemann, "Miniaturized bandstop filter using meander spurline and capacitively loaded stubs," ERTI Journal, vol 29, no. 5, Oct. pp 614-818, 2007
- [15] T.C Edward and M.B. Steer, Foundation of interconnect and microstrip design, 3rd Edition, John Wiley & Sons, LTD, pp. 83-112, 2000.
- [16] David M. Pozar, Microwave engineering, 2nd Edition, John Wiley & Sons Inc., pp. 56-176, 1998
- [17] T.C Edward and M.B. Steer, Foundation of interconnect and microstrip design, 3rd Edition, John Wiley & Sons, LTD, pp. 463-464, 2000.