

Analytical Approach of the In-Pipe Robot on Branched Pipe Navigation and Its Solution

Yoon Koo Kang, Jung wan Park, and Hyun Seok Yang

Abstract—This paper determines most common model of in-pipe robots to derive its degree of freedom in order to compare with the necessary degree of freedom required for a system to move inside pipelines freely in order to derive analytical reason for losing control of in-pipe robots at branched pipe. DOF of most common mechanism in in-pipe robots can be calculated by considering the robot as a parallel manipulator. A new design based on previously researched in-pipe robot PAROYS has been suggested, and its possibility to overcome branched section has been simulated.

Keywords—Branched pipe, Degree of freedom, In-pipe robot, Parallel manipulator.

I. INTRODUCTION

STARTING from industrial revolution, the rise of numerous industries has required many materials to be transported for human use and to interact with each industry. Especially, fluids such as gas, oil, chemicals, and water are required to be provided and transported to industrial machines, plants, and human beings by using different characteristics of pipes. These pipes, in most cases, were installed without any concerns for deterioration, aging, corrosion, fissures, cracks, or third-party damage. Moreover, considerable amount of pipes are being installed underground, not knowing the exact location of the pipes that were installed already. Thus when pipes are damaged with any reasons mentioned, process to find the location and amount of damage would be difficult. However the maintenance of pipelines cannot be ignored, therefore it is necessary to acknowledge the pipe's condition. Conventional inspection is usually made by human inspector to directly go inside pipes or use a cable-tethered robot with an on-board video camera system, where the robot is remotely controlled by an operator [1]. These methods are considered both difficult and expensive. In order to provide more efficient and inexpensive way to inspect pipelines, many in-pipe robots are being developed.

Current in-pipe robots propose various types of devices that can navigate through pipes either actively or passively, which are shown in Fig. 1. Passive device moves an inspection

tool inside a pipe by the fluid flow. These are called PIG (pipeline inspection gauge). PIG may cost less and move intuitively, but since no control is adapted inside them it is

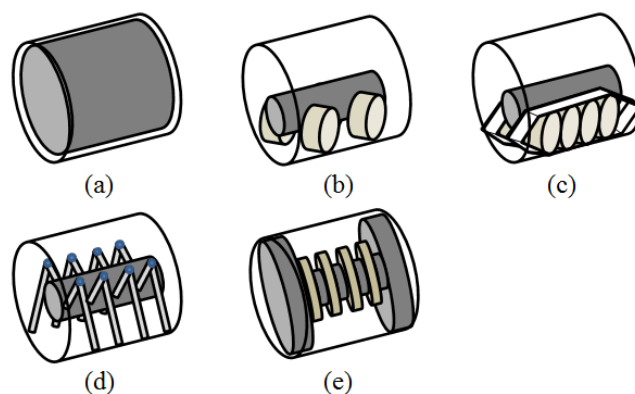

Fig. 1 Classification of in-pipe robots : (a) PIG type, (b) Wheel type, (c) Track type, (d) Walking type, (e) Inchworm type

almost impossible to control its speed and location. Active devices contain one or several drive mechanisms inside their body, allowing speed and location control. They can be largely divided into wheeled, track, walking, inchworm, snake, and screw type. Wheeled type in-pipe robots need to press the wheels against the pipe wall in order to keep contact and therefore gain propulsion. This kind of simple mechanism guarantees efficient energy usage. However it is hard to move through uneven terrains or vertical pipes. Track type is similar to the wheeled type, but it has advantage to overcome uneven terrain such as obstacles or rusty surface. Walking type in-pipe robots can overcome obstacles and can provide more various movement strategies and can move over obstacles that wheeled type can't, but they are much more complicated and hard to control. Inchworm type in-pipe robots can maneuver through various kinds of environments since they adapt motion of an inchworm, where clumper is used to fix its body to the pipe wall, and extensor provides displacement by its elongation. The movement of the robot may be flexible, overall operation speed is relatively slow and can have trouble facing slippery surface.

Although various types and strategies are being researched in in-pipe robot criteria, many requirements are still not achieved by these robots. A report on in-pipe robot survey proposes a list of evaluation criteria. The list suggests an in-pipe robot to develop an ability to be effective in pipes with various diameters and in pipes made of various materials, an

Yoon Koo Kang is with the Department of Mechanical Engineering, Yonsei University, 50 Yonsei-ro, Seodaemun-gu, Seoul 120-749, Korea (phone: +82-2-2123-2824; e-mail: aisz8802@naver.com).

Jung wan Park is with the Department of Mechanical Engineering, Yonsei University, 50 Yonsei-ro, Seodaemun-gu, Seoul 120-749, Korea (phone: +82-2-2123-2824; e-mail: avarta99@yonsei.ac.kr).

Hyun Seok Yang is with the Department of Mechanical Engineering, Yonsei University, 50 Yonsei-ro, Seodaemun-gu, Seoul 120-749, Korea (phone: +82-2-2123-2824; e-mail: hsyang@yonsei.ac.kr).

ability to function without emptying pipes and without interrupting service for consumers, an ability to be constructed in a modular format to allow for changes when sensor technology changes, an ability to provide inspection independently of the network flow, an ability to move through restrictive connections such as valves, elbows, and T joints, an ability to navigate autonomously, an ability to possess low cost, etc [2]. This kind of need for effective, nondestructive inspection techniques is becoming more and more demanding because the failure of modern pipelines could become catastrophic.

Among requirements mentioned above, the ability to navigate through T-branched pipes is one of the most critical issues since T joints are widely used in pipelines. Most in-pipe robots may move through perpendicular or/and curved pipes, but have trouble going through branched section such as T-branched joints. Some robots have adapted steering capability to guide its body to squeeze through branched section [3]. These newly developed methods propose possible ways to overcome branched pipes, but may have some restriction on its function and mechanically complex. Since development of in-pipe robots that can navigate through branched pipes are essential, it is also important to find why common in-pipe robots cannot move through branched pipes. If there is an analytical reason of this problem, the reason can reversely be used in order to solve the problem. Therefore, in this paper, an analytical reason for motion failure of common in-pipe robots moving through branched pipes is determined, and a new design solution which simply and directly solves the analytical reason that was verified is proposed.

II. PROCEDURE FOR BRANCHED-PIPE PROBLEM ANALYSIS

First of all, among recently developed in-pipe robots, a commonly designed mechanism is needed to be specified. A survey on in-pipe robots reports that more than half of total in-robots developed were adapting three-legged track or three-legged wheel type mechanism [2]. This is mostly due to its simplicity on control and structure, and mechanism using three legs intuitively seems enough to control the body's orientation inside pipelines without any difficulties. Therefore, analyzing this kind of three-legged motion mechanism can verify why most general mechanism of in-pipe robots field cannot navigate through branched pipes.

In this section, we introduce a commonly known term in mechanism design field; the degrees of freedom (DOF). Degree of freedom is the total number of independent displacements and/or rotations that specify the orientation of the body or system. DOF not only specifies one of the mechanical characteristics of the robot, but also verifies whether a system is sufficient to be controlled in certain environment. The calculation of degree of freedom might lead to analytical solution. In this section, the analogousness between a 3-DOF parallel manipulator and the three legged type in-pipe robots are introduced. The analogousness between the two mechanisms can be simplified as in Fig. 2. A parallel

manipulator is composed of three main parts; fixed platform, moving platform, and actuating limbs. Actuating limbs which are attached to fixed platform moves the moving platform freely, and many researches had been made for positioning the moving platform. The numbers of actuating limbs varies depending on the DOF the parallel manipulator wants to achieve. In this figure, a parallel manipulator with three limbs is presented since the

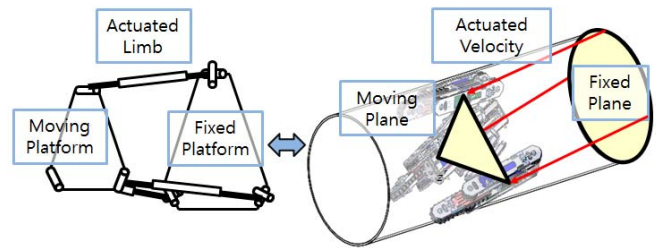

Fig. 2 Analogousness between parallel manipulator and three legged in-pipe robot

robot model is three-legged as well. This parallel manipulator-like form can be matched with in-pipe robots as following. The fixed plane is the perpendicular plane to a pipe and the moving plane is the plane crossing three contact points. The moving plane is varied by each track's velocity relative to fixed plane. Therefore, moving plane, fixed plane, and track's imaginary velocity limb of the in-pipe robot can be considered as the moving platform, fixed platform, and actuated limb [4]. Thus the calculation of DOF of in-pipe robot can be replaced to calculation of DOF of three-limbed parallel manipulator, as shown in (1),

$$M(D.O.F.) = 6(n - g - 1) + \sum_{j=1}^g f_j \quad (1)$$

$$= 6(11 - 12 - 1) + 3(3 + 1 + 1 + 1 - 1) = 3$$

where n represents total number of links, g represents total number of joints, and f represents the Degree of Freedom for each joints. Since the crawler must keep its contact with the pipe wall, one of allowed degree of freedom has been subtracted from total. Thus, the calculation result shows that three-legged type in-pipe robots mostly have total DOF of 3.

Since it is concluded that usual wheel or track type in-pipe robots with three legs has total degree of freedom of 3, degree of freedom required for in-pipe robots in order to move freely inside pipelines needs to be calculated for next step to be compared with each other. The translation and rotation required for in-pipe robot inside pipelines are shown in Fig. 3. It can be observed in the figure that a robot or a system inside pipelines needs x-axis translation, y-axis rotation, and z-axis rotation to

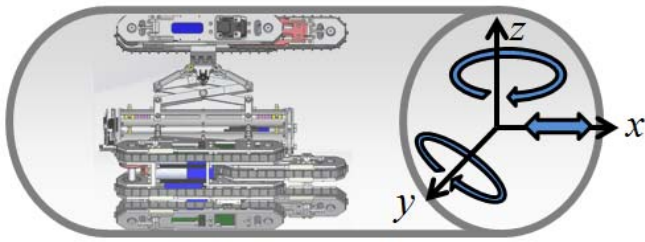

Fig. 3 Translation and rotation required for in-pipe robot inside pipelines to move freely

acquire complete information of the robot's orientation. Since the common in-pipe robots are wall-press type, y and z axis translation is restricted. Moreover, x-axis rotation would be meaningless since the shape of pipelines on x-axis is circle, having same shape as it rotates. Therefore, 3 DOF would be sufficient to provide information and controllability of an in-pipe robot inside pipelines.

Both numbers of degree of freedom of commonly designed in-pipe robots and degree of freedom required for in-pipe robots to control their orientation corresponds with one another, thus at normal straight pipe environment the in-pipe robots can control their posture freely. For next step, let's consider the moment when the in-pipe robot passes branched section (usually T-joints) as illustrated in Fig. 4. At the instantaneous moment the in-pipe robot passes through branched section, the in-pipe robot loses one of its contacts to the pipe wall, therefore losing one of its controllability. Therefore, the in-pipe robot will have 2 DOF at the instant moment, not sufficient to the DOF required for the in-pipe robot to determine its orientation. This kind of analytical approach can be applied to almost every in-pipe robots. For example, in-pipe robot using steering part or contains several module in series can go maneuver through branched section because both design has solved the problem of controllability loss [5], [6].

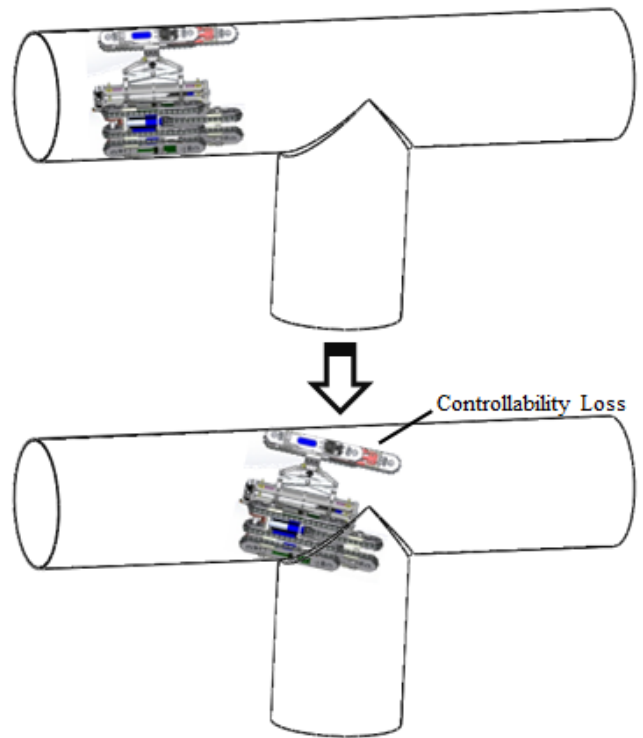

Fig. 4 Instant moment of an in-pipe robot crossing branched section

III. NEW MECHANISM DESIGN PROPOSAL

Since an analytical reason has been introduced by calculating and comparing the DOFs, it is easier to solve T-branched pipe passing problem by solving the analytical reason itself. In this section, a novel mechanism is introduced by using PAROYS

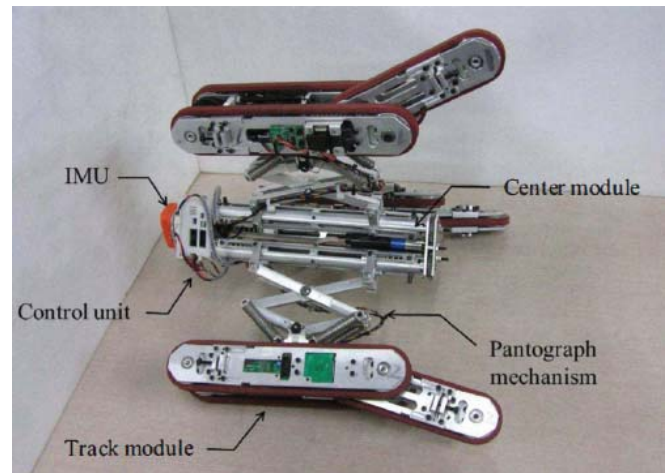

Fig. 5 Configuration of PAROYS

as a base mechanism, to safely pass T-branched pipes and contain controllability while doing it. In previous research, a track type three-legged in-pipe robot named PAROYS (Pipe Adaptive Robot of YonSei University) has been developed in order to cover some of the requirements mentioned in the introduction [7]. As shown in Fig. 5, PAROYS mainly can be divided into 3 parts; track module, center module, and

pantograph type adaptive module. Pantograph type adaptive module has larger working range than other linkage mechanism, such as 4-bar linkage, that has similar link length. Also its fordable structure helps to keep contact with the surface when robot passes uneven terrain and overcome obstacles. This kind of passive structure helps PAROYS to maneuver through vertical, horizontal, and curved pipes with various diameters without any additional control algorithm.

However it can be verified that since PAROYS also has structure of three-legged mechanism, it cannot be controlled at the instant moment of branched section passing. This can be confirmed by the analysis proved in previous section. Among strategies for solving DOF loss problem, most simple and robust choice of design would be adding one more redundant DOF to the robot; which is, adding additional leg to its body. This design not only will provide enough DOF to prevent controllability loss without any controlling algorithm, but also has advantage in further development on its orientation control, since the design keeps its parallel manipulator-like form. As mentioned before, control of moving platform of parallel manipulator has been established frequently, thus keeping this parallel manipulator-like form in robot design will guarantee its possibility to apply the control methods. Some of other in-pipe robots use additional stirring module or series of body module in order to curve through branched pipes [5], [6], but this design will keep its single body without any additional modules, making it simple but possible to solve the problem of controllability loss.



Fig. 6 Simplified model of newly proposed design

IV. SIMULATION RESULTS

In order to verify the possibility of newly designed PAROYS, simplified model of proposed design was drawn in CAD program Solid Works in order to perform simulation. As shown in Fig. 6, simplified version of newly proposed design contains

crucial factors such as four wall-pressing pantograph type track modules. Track parts are represented as a series of wheels because caterpillar mechanism takes much longer calculation for the simulation compared to the wheeled type. Results of the simulation are presented in Fig. 7. First of all, simulation of the model passing through branched section with gravity has been made as shown in Fig. 7. The arrow with letter G inside refers to the direction of gravity. The model safely passes through branched section without losing its contact and collapsing, able to crawl up against the gravity. Second simulation has been made in similar environment, but with different direction of gravity, as shown in Fig. 8. Even with the situation with gravity where common three-legged in-pipe robot will lose its contact and collapse because the gravity is pressing the robot to the branched section, the simulation result verifies that newly designed model will pass through branched section even it lost one of its controllability. Therefore, it can be concluded that problem analysis made in section II can be verified by these simulations. The focus for these simulations was to prove that adding one more redundant leg will manage controllability loss, so curving through branched section by calculating its curve trajectory can be applied in further developments.

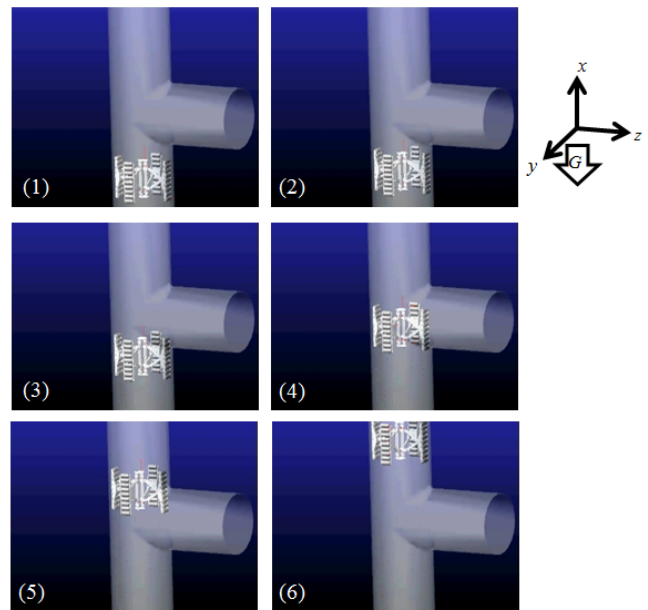

Fig. 7 Simulation results with x-axis gravity

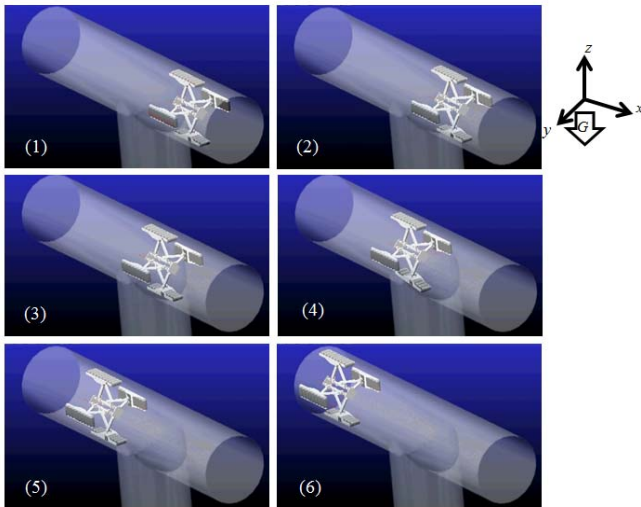

Fig. 8 Simulation results with z-axis gravity

V. CONCLUSION

This paper focused on solving analytical reason why common in-pipe robots cannot maneuver through branched pipelines and proposed a novel design to solve the problem. The analytical reason was determined by choosing most common in-pipe robot mechanism and calculating its degree of freedom. Comparing it with the degree of freedom required for a system to move freely inside pipelines, it is concluded that both DOF has total number of 3, and when the in-pipe robot passes through branched section, the robot will lose one of its controllability. This concept can further be applied to any in-pipe robots in similar mechanism, providing analytical help to solve their problems with branched pipelines. This paper proposed a newly designed model to provide solution for controllability loss, and its potential has been verified by simulations of simplified version of the proposed model. In further development, the model will be manufactured and its control algorithm that calculates the curve trajectory in order to curve through branched section by using moving platform control of the parallel manipulator will be developed, followed by experiments to verify it.

ACKNOWLEDGMENT

This work was supported by the IT R&D program of MKE/KEIT. [10043897, Development of 500 cGy level radiation therapy system based on automatic detection and tracing technology with dual-head gantry for 30% reducing treatment time for cancer tumors]

REFERENCES

- [1] Amir A.F. Nassiraei, Yoshinori Kawamura, Alizera Ahrary, Yoshikazu Mikuriya, and Kazuo Ishii, "Concept and design of a fully autonomous sewer pipe inspection mobile robot "KANTARO"", *IEEE International Conference on Robotics and Automation*, April 2007.
- [2] Josep M. Mirats Tur, and William Garthwaite, "Robotic devices for water main in-pipe inspection: a survey", *Journal of Field Robotics*, 2010, pp. 481-508.

- [3] Se-gon Roh and Hyouk Ryeol Choi, "Differential-drive in-pipe robot for moving Inside urban gas pipelines", *IEEE Transactions on Robotics*, vol. 21, 2005, pp. 1-17.
- [4] Jung wan Park, Woongsun Jeon, Yoon Koo Kang, Hyun Seok Yang, and Hyuksung Park, "Instantaneous kinematic analysis for a crawler type in-pipe robot", *IEEE International Conference on Mechatronics*, April 2011.
- [5] Erich Rome, Joachim Hertzberg, Frank Kirchner, Ulrich Licht, and Thomas Christaller, "Towards autonomous sewer robots: the MAKRO project", *Urban Water*, 1999.
- [6] Jungwan Park, Taehyun Kim, and Hyunseok Yang, "Development of an actively adaptable in-pipe robot", *IEEE International Conference of Mechatronics*, 2009.