

Study of Unsteady Swirling Flow in a Hydrodynamic Vortex Chamber

Sergey I. Shtork, Aleksey P. Vinokurov, and Sergey V. Alekseenko

Abstract—The paper reports on the results of experimental and numerical study of nonstationary swirling flow in an isothermal model of vortex burner. It has been identified that main source of the instability is related to a precessing vortex core (PVC) phenomenon. The PVC induced flow pulsation characteristics such as precession frequency and its variation as a function of flowrate and swirl number have been explored making use of acoustic probes. Additionally pressure transducers were used to measure the pressure drops on the working chamber and across the vortex flow. The experiments have been included also the mean velocity measurements making use of a laser-Doppler anemometry. The features of instantaneous flowfield generated by the PVC were analyzed employing a commercial CFD code (Star-CCM+) based on Detached Eddy Simulation (DES) approach. Validity of the numerical code has been checked by comparison calculated flowfield data with the obtained experimental results. It has been confirmed particularly that the CFD code applied correctly reproduces the flow features.

Keywords—Acoustic probes, detached eddy simulation (DES), laser-Doppler anemometry (LDA), precessing vortex core (PVC).

I. INTRODUCTION

STUDY of swirling flows represents very important branch of modern hydro- and aerodynamics science mainly because of numerous practical implications of flows with swirl [1]. For example in scrubbers and cyclone separators the flow swirling is used for cleaning exhaust gases and liquid fuel deaeration respectively. In burner devices intensive flow swirling, which leads to the vortex breakdown and formation of central recirculation zone, is utilized for the flame stabilization. However having obvious advantageous features the strong flow swirling may generate specific flow instability mode commonly referred to as a precessing vortex core

The work was financially supported by Ministry of Education and Science of the Russian Federation within the Federal Target Program “Scientific and Academic Cadres for Innovative Russia”, 2009 – 2013 (Grant No. 8289) and the Russian Foundation for Basic Research (Grants NN 11-08-01063, 10-08-01096, 10-08-01093). Authors acknowledge also partial support from the Lead Scientist (K. Hanjalic. NSU) Grant of Russian Federation Government (No. 11.G34.31.0046).

S. I. Shtork is with the Institute of Thermophysics of Siberian Branch of Russian Academy of Sciences, Novosibirsk, 630090 Russia (phone: +7-383-3331094; fax: +7-383-3308480; e-mail: shtork@itp.nsc.ru) and also with the Novosibirsk State University, Novosibirsk. 630090 Russia.

A. P. Vinokurov is with the Institute of Thermophysics of Siberian Branch of Russian Academy of Sciences, Novosibirsk, 630090 Russia (phone: +7-383-3306665; fax: +7-383-3308480; e-mail: lexavin91@mail.ru) and also with the Novosibirsk State University, Novosibirsk. 630090 Russia.

S. V. Alekseenko is with the Institute of Thermophysics of Siberian Branch of Russian Academy of Sciences, Novosibirsk, 630090 Russia (phone: +7-383-3307050; fax: +7-383-3308480; e-mail: aleks@itp.nsc.ru) and also with the Novosibirsk State University, Novosibirsk. 630090 Russia.

(PVC). It was reported previously that the PVC can facilitate the flame stabilization process through enhanced mixing that is critical for instance for burning of low calorific gaseous fuel or lean fuel-oxidant mixtures. Particularly, the latter case is applied to ensure ultralow level of NO_x formation [2]. On the other hand the hydrodynamical flow instability poses potential danger due to possibility of coupling with the thermoacoustic instability modes of the combustion chamber [3].

Much attention is paid now to nonstationary coherent structures in a form of precessing vortex rope emerging behind a hydroturbine at partial load or overload operation regimes. Resonance effect due to coincidence of the precessing frequency with the natural frequencies of the hydropower equipment may be cause of loud noise and powerful vibrations and eventually lead to severe damages of the hydroturbine.

To date the PVC phenomenon is described in a number of papers, e.g. [4]-[6]. However influence of different geometrical parameters of swirling device on the precessing vortex characteristics as well as methods for the precessing structure control still remain elusive. Besides, despite of long history of the PVC study at the moment there is no complete information that can provide comprehensive understanding of driving mechanisms of the phenomena. By this reason detailed study of the PVC still remains topical task.

In the context of said above the current work includes experimental and numerical study of swirling flow in an axisymmetric vortex chamber at variation of the flow swirling degree and the chamber geometry.

II. EXPERIMENTAL TECHNIQUE AND NUMERICAL PROCEDURE

A. Equipment

The experimental rig is a closed hydraulic loop which basically consists of a test section, 600 l water tank, a centrifugal pump and connecting plastic pipes. The pump with nominal flowrate 100 m³/h and head 3.2 atm. is controlled by a frequency converter which in turn is connected to a PC. The flowrate was measured using a standard diaphragm connected to a differential pressure transducer.

The test section designed to study unsteady vortex structures is an axisymmetric vortex chamber (Fig. 1). All the sections of the vortex chamber are made of transparent plexiglass allowing optical access to the flow area. The flow swirling is generated by means of a blade swirler. Then the swirling flow passes through a nozzle into expanding cylindrical chamber with diameter 104 mm. The nozzle and the blade swirler are removable that allows to vary the flow swirling degree and inlet boundary conditions. We used three

different nozzles with diameters 30, 40 and 52 mm and three different swirlers with different blade angles corresponding to swirl parameters $S = 0.53, 0.87$ и 1.33 as determined based on the swirler geometry [1]:

$$S = \frac{2}{3} \left(\frac{1 - (d_1/d_2)^3}{1 - (d_1/d_2)^2} \right) \tan(\phi), \quad (1)$$

where d_1 and d_2 – diameters of inner hub supporting the blades and outer diameter of the swirler, respectively, ϕ – blade angle.

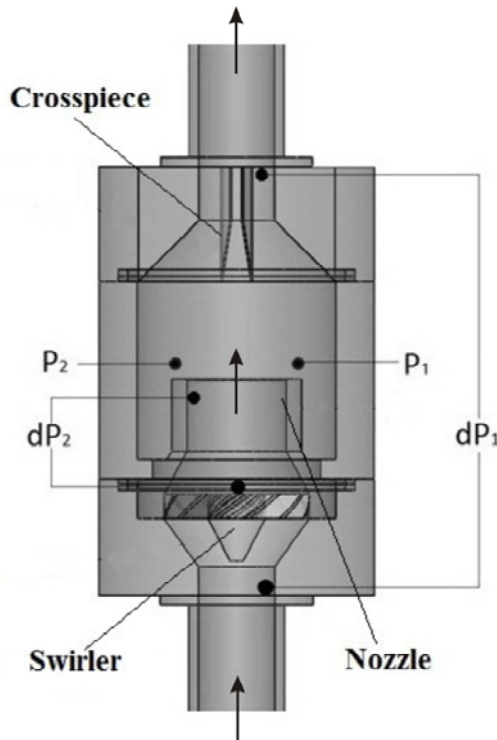

Fig. 1 Scheme of the test section

The pressure pulsations produced by the PVC are measured making use of a couple of identical piezoelectric probes, P_1 and P_2 , installed at diametrically opposite locations in order to use differential signal for detecting mode of pulsations related to the PVC. In fact at precessional motion of the vortex core the flow oscillations induced are registered by the pressure probes out of phase. So procedure of subtraction applied to the pressure signals gives doubling the signal mode linked to the PVC and eliminates noise which detected by the probes in phase. The differential signal is then analyzed using fast Fourier transformation (FFT) to obtain dominant frequency of the pressure pulsations which in turn is supposed to be frequency of the vortex precession.

Two differential pressure transducers were used for measuring static pressure differences dP_1 and dP_2 . First one is the pressure drop on the test section, while dP_2 is the static pressure difference between the center and periphery of the vortex which in fact is related to the vortex strength [4]. All

the measured signals including P_1 , P_2 , dP_1 and dP_2 were digitized using an ADC board connected to a PC for the data processing and storage.

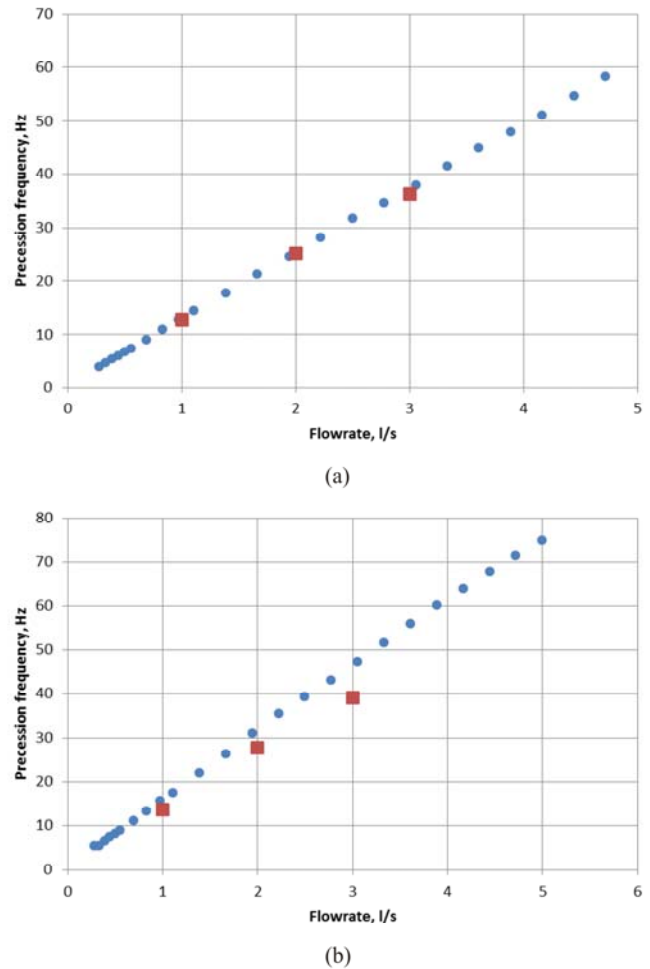

Fig. 2 Precession frequency vs. volumetric flowrate for nozzle diameter 40 mm. Symbols: circles – experiment, squares - calculation based on Star-CCM+. (a) - $S = 0.58$, (b) - $S = 0.87$

Velocity field measurements were performed with the aid of a laser-Doppler anemometer (LDA) installed on a programmable coordinate table that provides automatic positioning the LDA measuring volume with a precision of 0.02 mm. The LDA system works in a back-scattering mode and gives an accuracy of the velocity measurements of 0.5%.

B. Numerical code

In current work the numerical modeling has been done using Star-CCM+ CFD software. The unsteady flow was simulated based on volume grid with 400000 polyhedral cells and using method of detached eddy simulation (DES) with the Spalart-Allmaras model. As it was shown previously [7], [8] DES which in fact is combination of large eddy simulation (LES) and solving Reynolds average Navier-Stokes equations (RANS) can be suitable for calculation of flows similar to considered in our work.

III. RESULTS

Fig. 2 shows variation of the precession frequency as a function of volumetric flowrate and swirl parameter. It can be seen that the frequency has linear dependence on the flowrate and grows also with the swirling enhancement. Comparison of the experimental and simulated data demonstrates a fair coincidence with some difference in the curve slope appearing at increasing the swirl number.

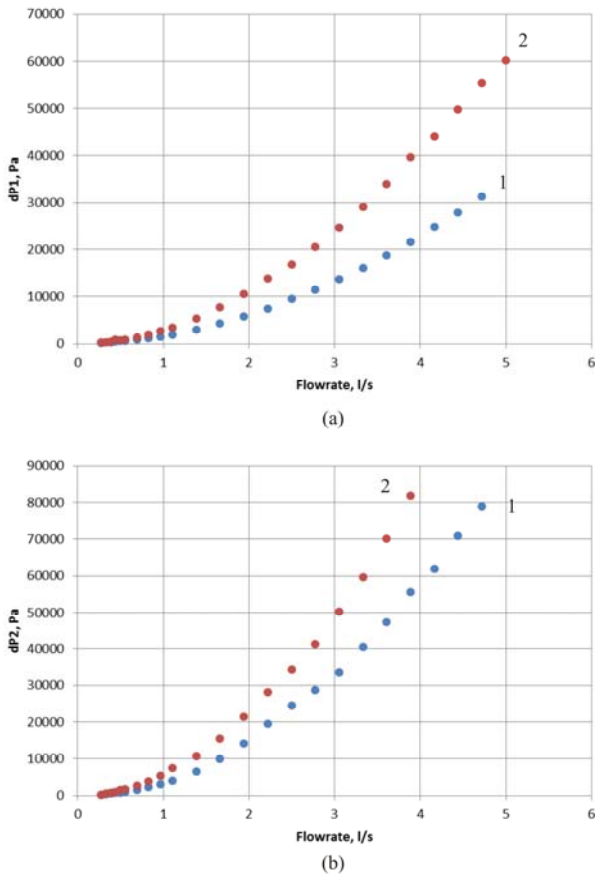

Fig. 3 Pressure drops dP_1 and dP_2 as a function of volumetric flowrate and swirl number S for nozzle diameter 40 mm. 1 – $S = 0.58$, 2 – $S = 0.87$. (a) – dP_1 , (b) – dP_2

Dependencies of pressure drop dP_1 and dP_2 on the flow rate as expected have a parabolic shape. Both dP_1 and dP_2 rise at swirling degree elevation (Fig. 3) and also the nozzle diameter decrease (this data is not presented here). The graphs in dimensionless form demonstrate independence of flow characteristics on Reynolds number Re at high turbulence conditions when $Re > 20000$ (Fig. 4).

The results on the velocity measurements are presented in Fig. 5 showing radial profile of the axial velocity component at a cross section close to the nozzle exit. The axial velocity distribution demonstrates presence of a central reverse flow zone (CRFZ) surrounded by annular jet with the velocity maximum located near the nozzle wall. The same graph shows results obtained from the numerical simulation which confirms its good agreement with the experiment. A difference can

observed only for far radial distance, i.e. outside the nozzle area.

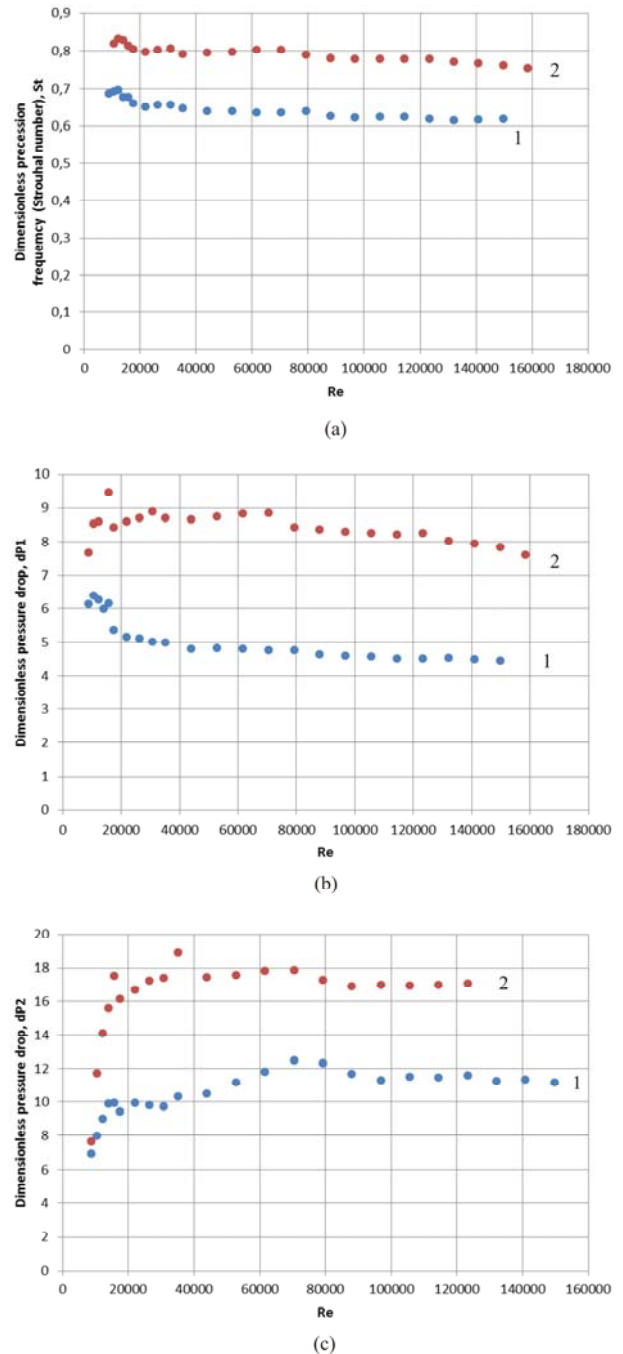

Fig. 4 Dimensionless parameters of swirling flow vs. Reynolds number Re for nozzle 40 mm. Dimensionless values were determined using the nozzle diameter and flowrate based averaged axial velocity at the nozzle. 1 – $S = 0.58$, 2 – $S = 0.87$. (a) – precession frequency, (b) – dP_1 , (c) – dP_2

As the numerical code is validated based on the experimental data it is possible now to explore the vortex flow features related to presence of the PVC. In Fig. 6 instantaneous flow field structure is visualized using λ_2 -criterion [9]. It can be noticed that the PVC has form of spiral

curled in direction opposite to the flow rotation. Namely such PVC axis geometry conforms with the case of high swirl jet flow when the CRFZ is generated [4].

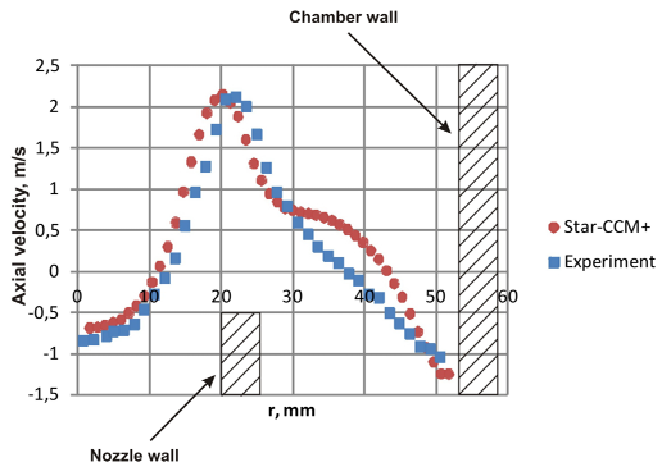

Fig. 5 Axial velocity radial profile above the nozzle. Nozzle diameter 40 mm

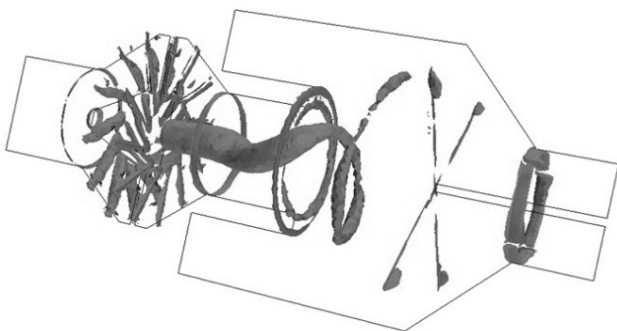

Fig. 6 PVC structure visualized by λ_2 - criterion. Numerical simulation using Star-CCM+

IV. CONCLUSION

Thus in present work experimental and numerical study of unsteady vortical flow in hydrodynamic vortex chamber has been performed. It has been shown that the high swirl level imparted to the flow leads to formation of a central reverse flow. This effect is followed by generation of certain flow unsteadiness in a form of precessing vortex core (PVC). The precession frequency has a linear dependence on the liquid flowrate and grows with the swirling degree enhancement and the nozzle diameter decrease. Numerical simulation carried out shows good agreement with the experimental data regarding mean velocity distributions and the precession frequencies. As it has been shown based on the simulation of instantaneous flow pattern the PVC has a form of spiral curled in direction opposite to the base flow rotation.

REFERENCES

[1] K. Gupta, D. G. Lilley, N. Syred, *Swirl Flows*. Abacus Press, 1984.

[2] E. C. Fernandes, M. V. Heitor, S. I. Shtork, "An analysis of unsteady highly turbulent swirling flow in a model vortex combustor," *Experiments in Fluids*, vol. 40, no. 2, pp. 177-187, Feb. 2006.

[3] N. Syred, "A review of oscillation mechanisms and the role of the precessing vortex core (PVC) in swirl combustion systems," *Progress in Energy and Combustion Science*, vol. 32(2), pp. 93-161, Apr. 2006.

[4] S. V. Alekseenko, P. A. Kuibin, V. L. Okulov, *Theory of Concentrated Vortices: An Introduction*. Springer, 2007.

[5] S. I. Shtork, C. E. Cala, E. C. Fernandes, "Experimental characterization of rotating flow field in a model vortex burner," *Experimental Thermal and Fluid Science*, vol. 31, pp. 779-788, July 2007.

[6] F. Martinelli, F. Cozzi, A. Coghe, "Phase-locked analysis of velocity fluctuation in a turbulent free swirling jet after vortex breakdown," *Experiments in Fluids*, vol. 53, pp. 437-449, Aug. 2012.

[7] P. R. Spalart, "Detached Eddy Simulation," *Annual Review of Fluid Mechanics*, vol. 41, pp. 181-202, Jan. 2009.

[8] J. Paik, F. Sotiropoulos, "Numerical simulation of strongly swirling turbulent flows through an abrupt expansion," *International Journal of Heat and Fluid Flow*, vol. 31, pp. 390-400, June 2010.

[9] J. Jeong, F. Hussain, "On the identification of a vortex," *Journal of Fluid Mechanics*, vol. 285, pp. 69-94, Feb. 1995.