

Application of Boost Converter for Ride-through Capability of Adjustable Speed Drives during Sag and Swell Conditions

S. S. Deswal, Ratna Dahiya, and D. K. Jain

Abstract—Process control and energy conservation are the two primary reasons for using an adjustable speed drive. However, voltage sags are the most important power quality problems facing many commercial and industrial customers. The development of boost converters has raised much excitement and speculation throughout the electric industry. Now utilities are looking to these devices for performance improvement and reliability in a variety of areas. Examples of these include sags, spikes, or transients in supply voltage as well as unbalanced voltages, poor electrical system grounding, and harmonics. In this paper, simulations results are presented for the verification of the proposed boost converter topology. Boost converter provides ride through capability during sag and swell. Further, input currents are near sinusoidal. This eliminates the need of braking resistor also.

Keywords—Adjustable speed drive, power quality, boost converter, ride through capabilities.

I. INTRODUCTION

A power-quality problem is an occurrence manifested in a nonstandard voltage, current, or frequency deviation that results in a failure or a miss operation of end-use equipment [1-2]. Power quality is a reliability issue driven by end users. There are three concerns firstly the characteristics of the utility power supply can have a detrimental effect on the performance of industrial equipment, secondly harmonics produced by industrial equipment, such as rectifiers or ASDs, can have a detrimental effect on the reliability of the plant's electrical distribution system, the equipment it feeds, and on the utility system and lastly the characteristics of the current and voltage produced by ASDs can cause motor problems. Although, there are number of power quality problems such as transients, interruption, sag/under-voltage, swell/overvoltage, waveform distortion, voltage fluctuations and frequency variations; voltage sag is the major reason for ASDs' shutdown. Voltage sag is a reduction of AC voltage at a given frequency for the duration of 0.5 cycles to 1 minute's time.

S. S. Deswal is with the Department of Electrical and Electronics Engineering, Maharaja Agrasen Institute of Technology, Rohini, Delhi, India (e-mail : satvirdeswal@hotmail.com).

Ratna Dahiya is with the Department of Electrical Engineering, NIT, Kurukshetra, Haryana, India (e-mail: ratna_dahiya@yahoo.co.in).

D. K. Jain is with the Department of Electrical Engineering, Deen Bandhu Chhotu Ram University of Science and Technology, Murthal, Sonapat, Haryana, India (e-mail : Jaindk66@yahoo.co.in).

Common causes of sags include starting large loads and remote fault clearing performed by utility equipment. Similarly, the starting of large motors inside an industrial facility can result in significant voltage drop (sag). A motor can draw six times its normal running current, or more, while starting. Creating a large and sudden electrical load such as this will likely cause a significant voltage drop to the rest of feeder.

Advancements in solid-state power electronics have led to a new generation of electronic ASDs', enabling commercial and industrial facilities to dramatically reduce energy use and operating and maintenance costs, while improving operations. ASDs' can be applied to AC motors regardless of motor horsepower or location within a facility. They can be used to drive almost any motorized equipment from a small fan to the largest extruder or machine tool. ASDs' unit consists of three basic parts as shown in Fig. 1. The rectifier converts the fixed frequency ac input voltage to DC. The inverter switches the rectified DC voltage to an adjustable frequency AC output voltage; it may also control output current, if required. The DC link connects the rectifier to the inverter and may also contain an inductor as well as a capacitor. Another concern for ASD applications is the sensitivity of controls to short duration voltage sags and interruption.

Existing drive topologies can be modified to achieve a higher level of immunity to line disturbances. These include adding more capacitors to the DC link, ride-through using load inertia, operating ASDs' at reduced speed and/or load, and using lower voltage motors [3-14]. An important distinction between each of the possible ride-through approaches is their ability to provide full-power ride-through, which is required by many applications. The conventional topology such of a boost converter can be used to maintain the DC-link voltage during voltage sag, and can either be integrated into new drives between the rectifier and the DC-link capacitors or retrofitted as an add-on module. The add-on module is used to retrofit existing drives with ride-through capabilities. During voltage sag, the boost converter will sense a drop in the DC-link voltage and begin to regulate the DC link to the minimum voltage required by the inverter which is user adjustable. In this paper, isolated boost converter has been applied at the DC link of the ASDs' at the design stage. The performance of ASDs' during power quality problems

such as voltage sag and swell has been simulated using MATLAB.

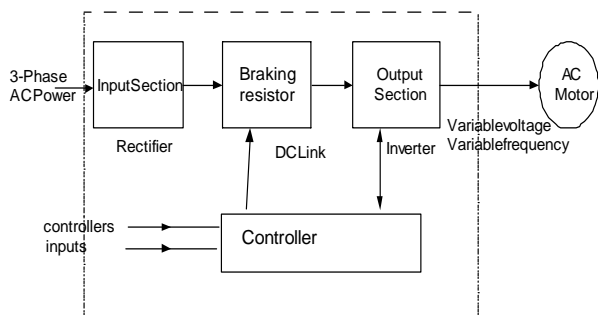

Fig. 1 Block diagram of conventional ASDs'

II. PROPOSED RIDE-THROUGH TOPOLOGY

Fig. 2 shows the proposed ride-through topology for adjustable speed drives which has been directly connected across a DC link to maintain the voltage level constant under power quality disturbances such as sags and swells.

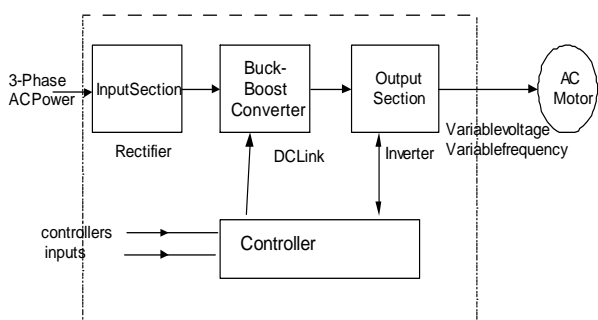

Fig. 2 Block diagram of ASD with isolated buck-boost converter

A. Boost Converter

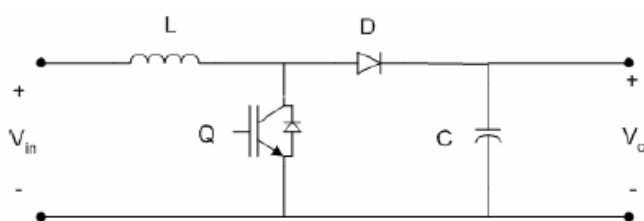

Fig. 3 Boost converter topology

This type of converter is a very well known step-up converter topology and widely used for low power switching power supplies. This topology schematic diagram is shown in Fig. 3. The operation of this converter can be described as follows, when the switch Q is in on state, the diode D is reverse biased, thus isolating the output stage of the converter. During this condition the input source supplies energy to the inductor L. When the switch is in off state, the output stage receives energy from the inductor as well as from the input source.

The voltage gain of the converter depends on the duty cycle

value D, and it can be calculated by means of equation (1) as:

$$V_o/V_{in} = 1 / (1-D) \quad (1)$$

Although from equation (1) it can be inferred that this converter can have very large voltage gains if a proper duty cycle is selected, a maximum gain of two is achievable in practical converters. This difference between the ideal voltage gain and the practical voltage gain are due to losses in the inductor, diode and switch. For cases where the output voltage requirements are higher than two or three times the input voltage the use of this topology is not appropriate, because of the reduced efficiency. It is important to consider that this topology does not need transformers and the voltage stress for the switch is relatively low when compared to other DC-DC step-up converter topologies. The use of this topology to step up the voltage supplied by energy storage devices is feasible when the ratio between the input voltage and the output voltage is no higher than two or three and when no galvanic insulation is required.

B. Isolated Boost Converter

This DC-DC converter topology is an extension of the conventional boost converter. In this case the input and output sides of the converter are isolated by a transformer. The function of the transformer is not only to isolate the grounds of the input and output but also to provide most of the voltage gain of the converter. The circuit schematic of this converter is shown in Fig. 4. As can be seen from this figure the converter is constituted by two switches two inductors one transformer, snubber capacitor and resistor, four diodes and two output capacitors.

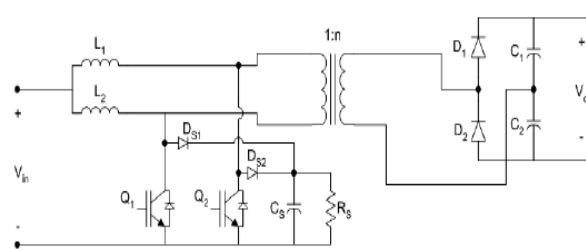

Fig. 4 Isolated boost converter topology

Basically in this case two boost converters are connected in parallel. The switches Q1 and Q2 operate alternating in order to invert the input DC voltage to get a square wave voltage at the input terminals of the transformer. This voltage is then stepped up by the transformer and then rectified by the half wave rectifier at the secondary part of the circuit. Although most of the voltage gain of the converter is due the transformer the presence of the input inductors L1 and L2 produce a small gain in the same manner as in a boost converter. Also these two inductors allow the converter to work in continuous conduction, which reduces the input current peak value. This makes this converter suitable for high power applications. It is obvious that this topology has a much

higher component count than the previous one, but has the advantage of being suitable for high power applications and the voltage gain characteristic is better for high gain values than the boost converter. The main problem of this topology is the high switch stress, which can be about 4 times the input voltage of the converter.

The advantages of the Boost converter are: it can provide ride-through for sags up to 50%, the DC-link voltage can be regulated as required by the inverter, and is user adjustable. And the disadvantages are: additional hardware is required, which will have to be suitably rated due to the additional current drawn during a voltage sag, in the case of an outage, the boost converter will not be able to provide ride-through, and the drive will trip.

III. PROBLEM FORMULATION

ASDs' are often susceptible to voltage disturbances, such as voltage sags and swells during balance and unbalance conditions. The above said power quality problems are the major cause of ASDs'/industry process disruptions. Depending upon the characteristics of the disturbance, the ASD's controlled process may be momentarily interrupted or permanently tripped out. To avoid such circumstances, ASD's have been provided a ride through topology or an external energy backup during fault conditions. An energy storage device like battery, capacitor, super-capacitors, superconducting Magnetic Energy Storage, load inertia, boost converter, flywheels, fuel cell etc have to be connected across

DC-link to maintain the required voltage level. In this paper the objective is to investigate the methods to enhance adjustable speed, induction motor drives tolerance to voltage sags through the addition of boost converter by keeping the DC link voltage level constant. In this topology the boost converter is directly connected across Units the DC link to maintain its level constant at any abnormal condition of voltage sag or swell.

IV. MATLAB SIMULATION AND RESULTS

A. Balanced Sag Conditions

MATLAB Simulink Power System block set tool box has been used to study the performance of isolated boost converter topology connected directly across DC link. The MATLAB simulated circuit is shown in Fig. 5. The simulation has been done for balanced sag conditions. The voltage sag of 50% has been introduced between the time intervals from 0.75 sec to 1 sec. The various resultant waveforms generated are shown in Fig. 6. The DC voltage remains constant during sag condition and the drive performance does not deteriorate as the machine current, torque and speed remains same. Further, the source current drawn is near to sinusoidal. The THD in the source current is reduced to a low level as is evident from Fig. 7.

Open Science Index, Electrical and Computer Engineering Vol:2, No:11, 2008 publications.waset.org/9185.pdf

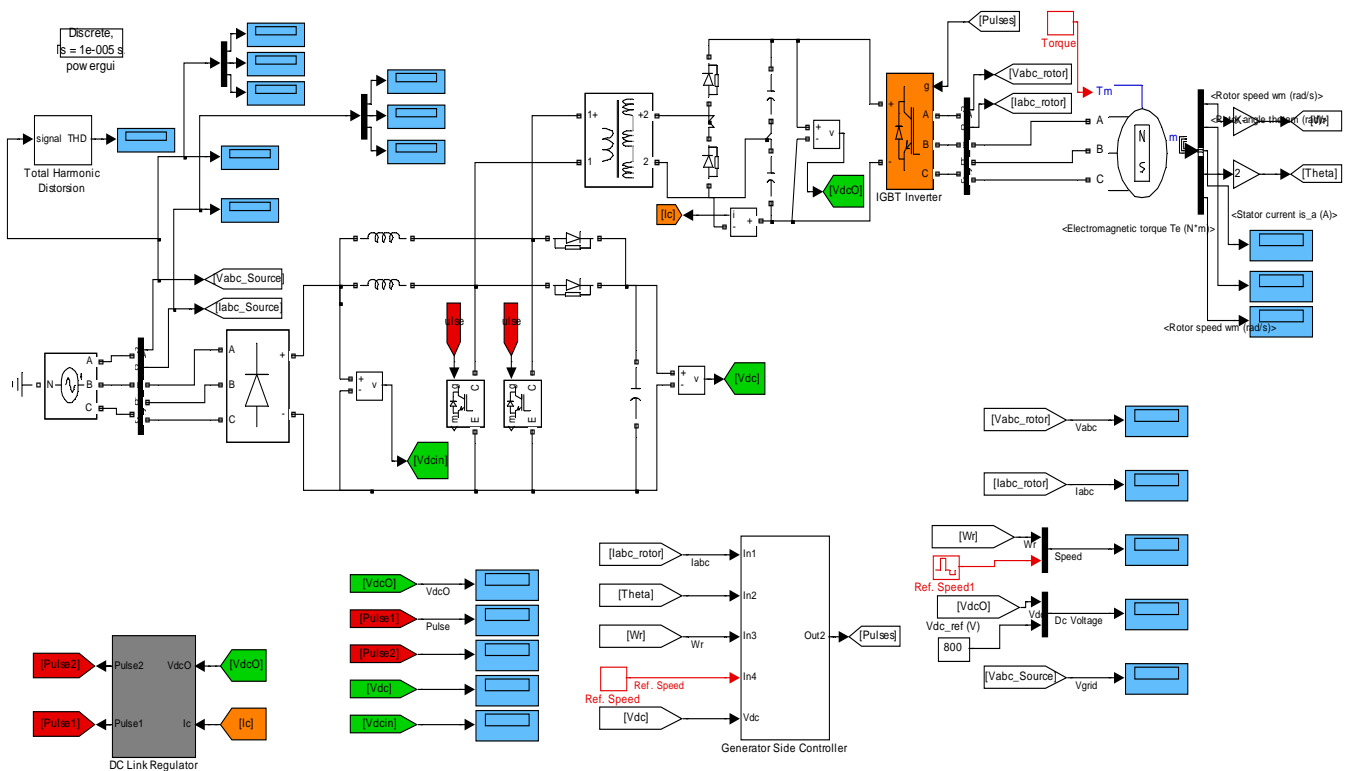

Fig. 5 MATLAB simulation of ASD's with isolated boost converter

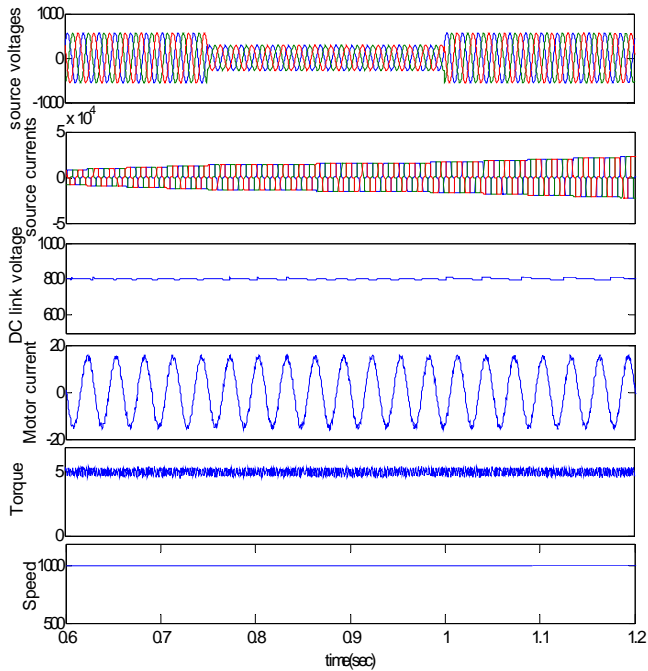

Fig. 6 Source voltage, source current, DC link voltage, motor current, torque and speed with a balanced sag of 50%

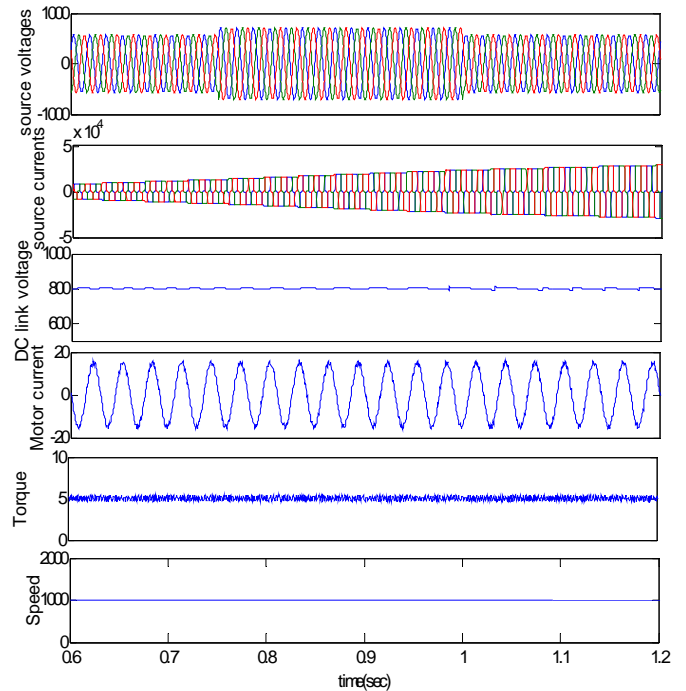

Fig. 8 Source voltage, source current, DC link voltage, motor current, torque and speed with a balanced swell of 25%

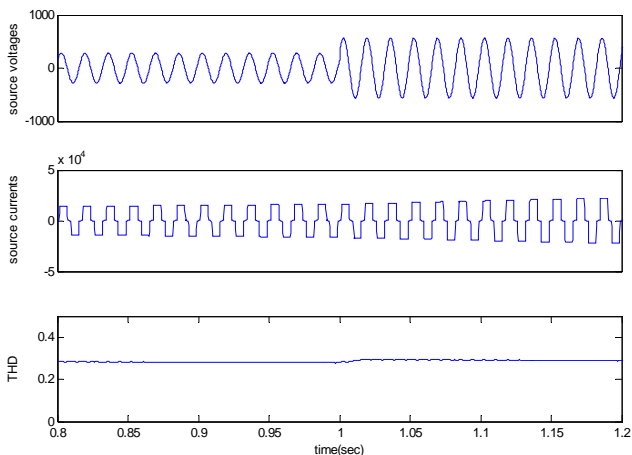

Fig. 7 Source voltage, source current and current THD with a balanced sag of 50%

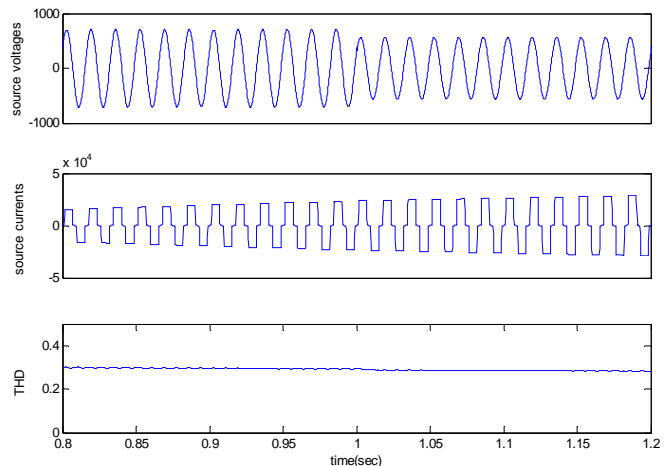

Fig. 9 Source voltage, source current and current THD with a balanced swell of 25%

B. Balanced Swell Conditions

The simulation has been set for balanced swell conditions. The voltage swell of 25% has been introduced between the time intervals from 0.75 sec to 1 secs. The various resultant waveforms generated are shown in Fig. 8.

During the swell also, the DC link voltage remains constant and there is no need to have a braking resistor, which is generally used to maintain the constant DC link voltage.

V. CONCLUSION

This isolated boost converter topology is capable of providing ride through for voltage sags as well as voltage swell. Several DC-DC topologies are available to perform this function. This proposed boost converter topology maintains the DC link voltage level constant during the abnormal conditions. For this reason a simple design procedure for maintaining the DC link voltage constant is presented. The effectiveness of the proposed ride through topology is shown by means of simulations.

From these results is clear that the boost converter dynamic response is fast enough to respond to the abnormal conditions and avoid the effects of the voltage sags and swells on the

adjustable speed drive.

interests include Induction Machines, ASD's, power quality, motor drives, renewable energy.

REFERENCES

- [1] G.T. Heydt, Electric Power Quality, 2nd ed. WestLafayette, Stars in a Circle, 1994.
- [2] A. Ghosh and G. Ledwich, Power Quality Enhancement Using Custom Power Devices. Kulwer Academic, 2002.
- [3] A.von Jouanne , P. Enjeti and Basu Dev Banerjee, "Assessment of ride-through alternatives for adjustable speed drives," IEEE Transactions on Industry Applications, Vol.35, No.4, July/August 1999, pp.908-916.
- [4] H.G. Sarmiento and E. Estrada, "A voltage dip study in an industry with adjustable speed drives," IEEE Industry Applications Magazine., Vol. 2, pp. 16-19, January/February 1996.
- [5] M.H.J. Bollen and L.D. Zhang, "Analysis of voltage tolerance of AC adjustable-speed drives for three-phase balanced and unbalanced dips," IEEE Transactions on Industry Applications, Vol. IA-36, no.3, May/June 2000, pp. 904-910.
- [6] M.H.J. Bollen, "Characterization of voltage dips experienced by three-phase adjustable-speed drives," IEEE Transactions on Power Delivery, Vol. PD-12, no.4, October 1997, pp.1666-1671.
- [7] Duran-Gomez, P.N. Enjeti and B. Ok Woo, "Effect of voltage dips on adjustable-speed drives: a critical evaluation and an approach to improve performance," IEEE Transactions on Industry Applications, Vol. IA-35, no.6, November/December 1999, pp.1440-1448.
- [8] J. Amantegui, F. Pazos, "Voltage dip measurement campaign in Spanish MV systems preliminary results 1996-1998," CCO2 Paris 1998
- [9] R.A. Epperly, F.L. Hoadley and R.W. Piefer, "Considerations when applying ASD's in continuous processes," IEEE Transactions on Industry Applications, Vol. IA-33, no.2, March/April 1997, pp. 389-396.
- [10] "Voltage dips, short interruptions and voltage variations immunity tests", IEC Std. 61000-4-11.
- [11] Math H.J. Bollen, "Understanding Power Quality Problems, Voltage Sags and Interruptions", IEEE Press Series on Power Engineering, 2000.
- [12] B. J. Seibel, T. M. Rowan, and R. J. Kerkman, "Field-oriented control of an induction motor machine in the field weakening region with DC-link and load disturbance rejection," *IEEE Trans. Ind. Applicat.*, vol. 33, pp. 1578-1584, Nov./Dec. 1997.
- [13] J. Holtz and W. Lotzkat, "Controlled AC drives with ride-through capability at power interruption," IEEE Transactions on Industry Applications, Vol. IA-5, no.5, September/October 1994, pp. 1275-1283.
- [14] A. van Zyl, R. Spée, A. Faveluke and S. Bhowmik, "Voltage dip ride-through for adjustable-speed drives with active rectifiers," IEEE Transactions on Industry Applications, Vol. IA-34, no. 6 November/December 1998, pp. 1270-1277.

S. S. Deswal received his B.Tech degree in Electrical Engineering from R.E.C. Kurukshetra , Kurukshetra University ,Haryana, India in 1998, the M.E degree in Electrical Engineering(Power Apparatus and Systems) from Delhi College of Engineering, Delhi University, Delhi, India in 2005, and is currently pursuing the Ph.D. degree from N.I.T, Kurukshetra a Deemed University, Haryana, Delhi. Currently, he is working as a Senior Lecturer in EEE Department with the Maharaja Agrasen Institute of Technology, Rohini, Delhi under GGSIP University , Delhi, India. Before joining MAIT in 2006, he was with C.R.Institute of Technology, Kanjhawala, Delhi and was working as Head of the Electrical and Instrumentation Control Department, from 1998 to 2006. His research interests include ASD's , power quality, motor drives, Renewable energy .

Ratna Dahiya received her B.Tech from GBU, Pant Nagar and M.Tech and Ph.D. degree degree in Electrical Engineering from R.E.C, Kurukshetra, Kurukshetra University, Haryana, India. Currently, she is working as Asstt. Prof. in Electrical Engineering Department with the NIT, Kurukshetra (Deemed University), Haryana, India. Her research interests include SMES, Induction Machines, ASD's, power quality, motor drives, Renewable energy.

D. K. Jain received his B.Sc. (Engg), M.E (Electrical Engg.) and Ph.D. degree in Electrical Engineering from R.E.C, Kurukshetra, Kurukshetra University, Haryana, India. Currently, he is working as Asstt. Prof. in Electrical Engineering Department with the Deen Bandhu Chhotu Ram University of Science and Technology(DCRUST), Murthal, Haryana, India. His research