

Introducing Fast Robot Roller Hemming Process in Automotive Industry

Babak Saboori, Behzad Saboori, Johan S. Carlson, Rikard Söderberg

Abstract—As product life cycle becomes less and less every day, having flexible manufacturing processes for any companies seems more demanding. In the assembling of closures, i.e. opening parts in car body, hemming process is the one which needs more attention. This paper focused on the robot roller hemming process and how to reduce its cycle time by introducing a *fast roller hemming process*. A robot roller hemming process of a tailgate of Saab 9³ SportCombi model is investigated as a case study in this paper. By applying *task separation*, *robot coordination*, and *robot cell configuration* principles in the roller hemming process, three alternatives are proposed, developed, and remarkable reduction in cycle times achieved [1].

Keywords—Cell configuration, cycle time, robot coordination, roller hemming.

I. INTRODUCTION

NOWADAYS that customer demands fluctuate regularly, companies need to change their manufacturing processes in a way that they can stay alive and keep their market share. It is also a case in the automotive industry that every now and then new processes are introduced. It is a must for company owners to gradually improve their manufacturing processes. This improvement process should be in a way for companies to be able to produce their new products in a more competitive and efficient way. There are many ways to enhance production processes, not only in product quality aspect but also in appearance, e.g. by substituting the welding process of car body closures into assembling inner and outer panels [1].

In this respect different hemming processes are introduced such as *press-and-die*, *table-top*, and *roller hemming* to

This work is part of "Produktionsverifieringssystem för rullfalsning" project, which is a collaboration project between Saab Automobile AB, Svensk Verktygsteknik, and Fraunhofer-Chalmers research Centre. This work was supported by VINNOVA (the Swedish Governmental Agency for Innovation Systems) through the MERA program (Manufacturing Engineering Research Area).

Babak Saboori is with the department of Product and production development at Chalmers University of Technology (email: saboori@student.chalmers.se).

Behzad Saboori is with the department of Product and production development at Chalmers University of Technology (email: behzads@student.chalmers.se).

Johan S. Carlson is with the department of Geometry and motion planning at Fraunhofer Chalmers research centre (e-mail: johan.carlson@fcc.chalmers.se).

Rikard Söderberg is with the department of Product and production development at Chalmers University of Technology (email: rikard.soderberg@chalmers.se).

enhance the capacities and capabilities of assembly processes in automotive industry [2], [3].

Press-and-die and table-top hemming processes are well suited in mass production due to their low cycle time. On the other hand these two processes are product specific, i.e. switching between one product to another is costly as well as it increases production time. Hence the need of flexible hemming processes is more demanding. In this respect roller hemming process could be a good alternative for assembly processes. Although beyond its high flexibility, it has higher cycle time compared to conventional methods; press-and-die and table-top. This paper tries to introduce a *fast roller hemming process* to tackle its high cycle time problem while keeping its quality and flexibility. Before that it is good to have an overview in the roller hemming process [1].

II. ROLLER HEMMING PROCESS

Robot roller hemming process is a relatively new process which was introduced at the market in the late 90s. This process has great application areas in assembling closures, e.g. hoods, decks, lids, fenders, and tailgates. Closures are comprised of three main components including inner panel, reinforcement, and outer panel [4].

The manufacturing of closure is done in three main steps. In the first step these three components are manufactured separately by stamping, trimming, and flanging subsequently. In the flanging process of the outer panel a peripheral edge of an outer panel is formed to extend substantially perpendicularly relative to the body of the outer panel. Then the closure's components are transported to subassembly line where the reinforcements are joined to the inner panels by spot welding, riveting, or clinching. Finally the complete inner panel is joined to the outer panel by adhesive bonding and hemming processes [4]. In the roller hemming process a robot guides the roller along the product to bends the outer panel over the inner panel, see Fig. 1 [2].

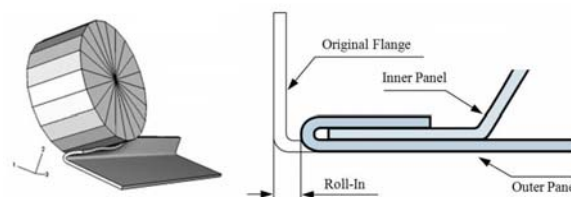

Fig. 1 Roller hemming process

The roller hemming process is usually accomplished in three steps in which the roller orientations and TCPs, Tool Center Point, can vary [1]. The first two steps are called *prehemming* and the third one is called *final hemming*. In the roller hemming process, three different rollers usually are exploited, i.e. using three rollers in three different steps of hemming process. In the prehemming steps the roller folds the outer panel to get 60 degree and 30 degree respectively. But in the final hemming step, roller would completely fold the outer panel on the inner panel. This would happen by applying extra forces, see Fig. 2 [2].

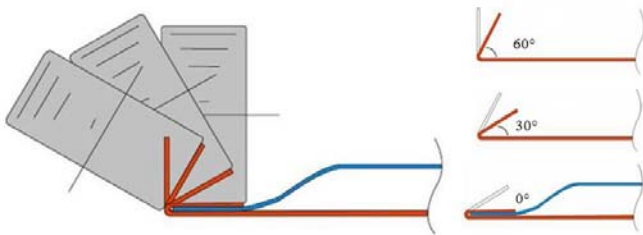

Fig. 2 Three steps in the roller hemming process

As roller hemming process is accomplished in three steps, the hemming process cycle time is higher than conventional hemming processes. Hence it is crucial to reduce the roller hemming process cycle time.

III. CYCLE TIME REDUCTION

To be able to shorten the high cycle time of roller hemming process, three principles are introduced which can be applied in any roller hemming processes. These principles are described in the following.

A. Task separation

The whole roller hemming process should completely be investigated, i.e. necessary tasks should be defined and allocated to different resources [1].

B. Robot coordination

Coordinate robots to work simultaneously. This would minimize the robots' idle time during the whole roller hemming process [6], [7].

C. Cell configuration

Configure robot cell layout, i.e. change the orientation of the robot cell components [8].

In this respect task separation, robot coordination, and cell configuration principles are applied in a case study of automotive industry.

IV. CASE STUDY

This case study is a robot roller hemming process at Saab Automobile AB, Sweden. Particularly robot roller hemming process of a tailgate of Saab 9³ SportCombi model is investigated in this paper [1]. This robot cell is comprised of

four different components; two FANUC robots, folding fixture, loading/unloading fixture, and tool changers. The robot roller hemming cell is depicted in Fig. 3 [1], [3].

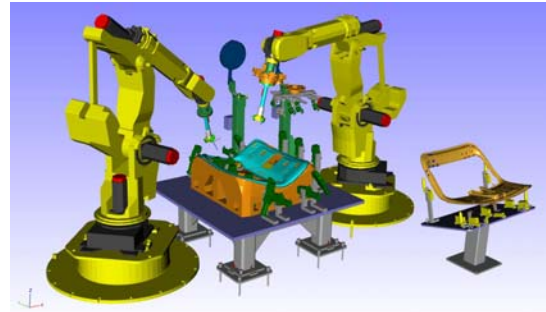

Fig. 3 Robot cell layout at Saab Automobile AB

The roller hemming process of a tailgate is divided into two different parts, i.e. roller hemming of the upper and lower part of a tailgate. One robot is responsible to load and unload a tailgate as well as hem the lower part of a tailgate while another robot is only responsible for hemming the upper part of it. One robot should wait until the other one completely hem the tailgate and leave the hemming surface. It is important to mention that the robots are not allowed to stop in the middle of hemming process. Any stops on the hemming surfaces would cause quality problems.

The roller hemming process was simulated in IPS software, i.e. Industrial Path Solution software is simulation software developed by Fraunhofer-Chalmers research Centre. IPS software mainly entangles with robot path planning and cable simulation [7], [9], [10]. After simulating the roller hemming process in IPS software, the initial cycle time of 90 s, is acquired [1].

Task separation and robot coordination principles are applied in the roller hemming process and simulated in the IPS software. By applying task separation principle, three different tasks are identified for the hemming process of a tailgate; loading, unloading, and hemming process. Then loading and unloading tasks are allocated to a conveyor system while both of the robots would only be responsible to do the hemming process, see Fig. 4 [1].

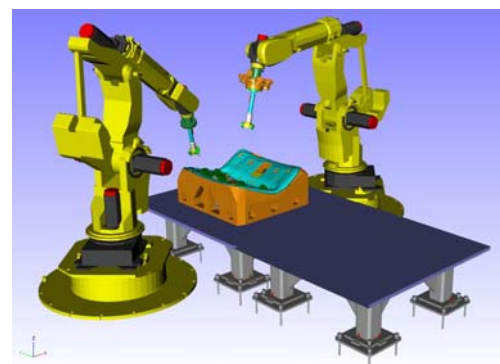

Fig. 4 Robot cell layout after applying task separation and robot coordination principles

Furthermore robot coordination principle is applied to make robots work simultaneously. By applying this principle, some collisions between the robots were figured out. The problem was solved by exploiting a collision free path planner in IPS software as well as defining specific time lags for each robot during the hemming process [7], [11], [12].

By applying task separation and robot coordination principles three different alternatives are proposed for the roller hemming process of tailgate. These alternatives are common in robot tasks, see Fig. 4, and the only difference is in the way of hemming the tailgate, i.e. both robots start to hem the tailgate from the same or different point. These three alternatives are described in the following [1].

A. Alternative A

One robot hems the tailgate right after the other one finishes with its task.

B. Alternative B

Two robots start from the same point on the tailgate.

C. Alternative C

Each robot starts from different side of the tailgate.

Alternative A has no robot coordination consideration whereas it is applied in alternative B and C. These alternatives are simulated in IPS software and different cycle times are acquired based on robot coordination and path planning solutions. Furthermore production rate for each alternative is calculated in (1).

$$\text{Production rate (1/hr)} = 3600 / \text{Cycle time} \quad (1)$$

Cycle time and production rate of roller hemming process for each alternative are given in Table I [1].

TABLE I
CYCLE TIME AND PRODUCTION RATE FOR DIFFERENT ALTERNATIVES

Alternative	Cycle time (s)	Production rate (1/hr)
A	71	51
B	61	59
C	59	61

As it is shown in Table I, cycle time for alternative A, B, and C are 71, 61, and 59 s, respectively. Moreover, by comparing the initial cycle time of roller hemming process and the one achieved from alternative C, the overall cycle time reduction of 34 percent is acquired. Among 34 percent reduction in cycle time, 17 percent is due to applying the task separation and 17 percent is because of the implementation of robot coordination principle. The corresponding calculations on cycle time reduction, robot coordination, and task separation impacts are as following [1].

$$\text{Cycle time reduction: } (90 - 59) / 90 = 34 \%$$

$$\text{Robot coordination impact: } (71 - 59) / 71 = 17 \%$$

$$\text{Task separation impact: } 34 - 17 = 17 \%$$

Cell configuration is another principle which can reduce cycle time of roller hemming process [8]. In this respect it is important to first identify whether the robot cell components are in the robot operability region or not. Robot operability region is an area that each robot with respect to its physical and operational constraints has the possibility to reach and do the task [13]. In order to specify the robot operability region, *robot specifications* and *cell layout dimensions* need to be investigated. By using robot specifications, number of robot links, their lengths, and robot operability region are identified.

As in Fig. 5 a circle with radius of 2405 mm, can resemble robot operability region [1], [3].

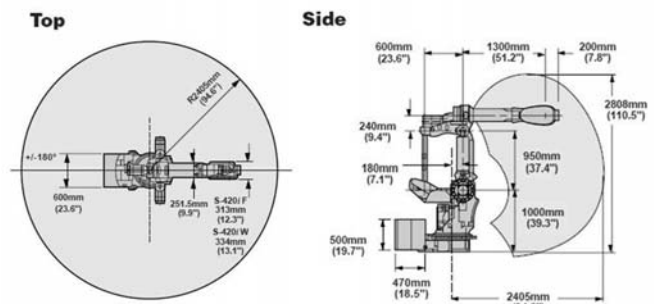

Fig. 5 Robot specifications and operability region

The whole cell layout including robots, folding fixture, tool changers, loading/unloading fixture, and robot operability region are shown in Fig. 6 [1].

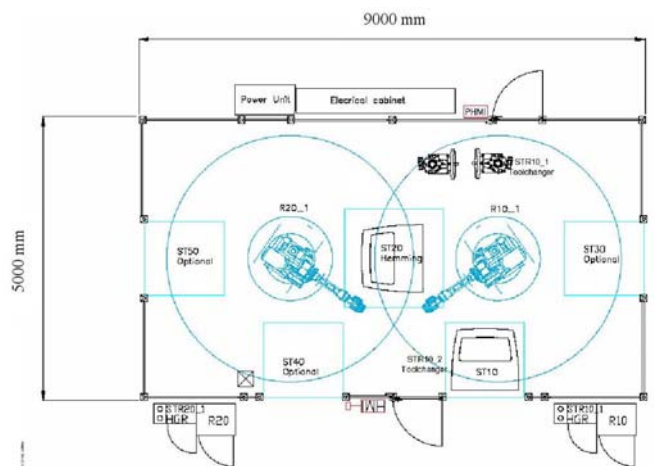

Fig. 6 Robot cell layout and operability region

As in Fig. 6, the folding fixture is in the operability region of robots. It means that there is a possibility for robots to reach different points of the tailgate. But as it was recognized from the simulation of roller hemming process in IPS software, one robot spent a lot of time in the corners of lower part of the tailgate. Hence it is tried to change the folding fixture orientation in terms of rotation and displacement [1].

Different values for displacement, rotation, as well as combination of these two are investigated. Thereafter different robot cell configuration alternatives achieved. Finally the best configuration with the optimum orientation for the folding fixture is chosen and applied in the robot cell simulation, see Fig. 7 [1].

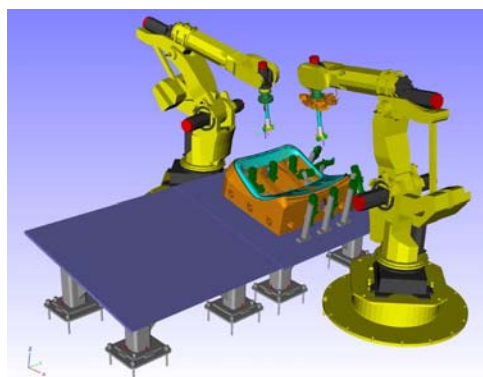

Fig. 7 Robot cell layout after applying cell configuration principle

By applying cell configuration principle, better cycle time for each three alternatives mentioned earlier in this paper was achieved. This makes robots to hem the tailgate in an easier and quicker way. Overall cycle time reduction is then calculated for alternative A, B, and C, see Table II. All the cycle time values in this table are excluding loading and unloading time which tailgate spend in the conveyor system.

TABLE II
 CYCLE TIME REDUCTION FOR DIFFERENT ALTERNATIVES

Alternative	Cycle time (s) cell configuration		Cycle time reduction (s)	Production rate (1/hr)
	Before	After		
A	54.7	39.5	15.2	27.8
B	27.8	21.0	6.8	24.5
C	27.2	19.5	7.7	28.3

As in Table II, the cycle time reduction for different alternatives is approximately 26 percent. It means that folding fixture configuration was quite effective. Furthermore among different alternatives proposed, alternative C has the least cycle time, 19.5 s, hence this alternative is recommended to be used for the roller hemming process.

V. CONCLUSION

In this paper cycle time reduction for the roller hemming process is being considered to introduce a *fast roller hemming process*. By investigating robot coordination and task separation principles, three different alternatives are suggested for the roller hemming process. In general, by comparing the current situation with alternative C, the overall cycle time reduction of 34 percent is achieved, from which 17 percent is due to robot coordination and 17 percent by applying task separation. A robot cell configuration principle is also applied

for these three alternatives to further improve the cycle time achieved by robot coordination and task separation principles. In this respect folding fixture is configured and new cycle time is gained. It is demonstrated the cycle time reduction of 26 percent after applying the cell configuration improvement for different alternatives. Consequently alternative C is recommended for hemming the tailgate of Saab 9³ SportCombi model. This alternative has the least cycle time of 19.5 s, i.e. excluding loading and unloading process. As a conclusion by applying task separation, robot coordination, and cell configuration principles the overall cycle time reduction of 42 percent for the roller hemming process is achieved.

REFERENCES

- [1] Babak Saboori, Behzad Saboori, "Development of roller hemming process in automotive industry – Saab Automobile AB," M.S. thesis, Dept. Product and Production Development, Chalmers University of Technology, Gothenburg, Sweden, 2009.
- [2] B. Jonkers, "Voestalpine Polynorm Automotive," M.S. thesis, Universiteit Twente, Enschede, Netherlands, 2006.
- [3] Andreas Engdahl, "En jämförande studie av rullfalsning kontra konventionell falsning," B.S. thesis, Dept. Mechanical Eng., Chalmers University of Technology, Gothenburg, Sweden, 2006.
- [4] Mats Sigvant, "The hemming process, a numerical and experimental study," Dept. Mechanical Eng., Chalmers University of Technology, Gothenburg, Sweden, 2003.
- [5] Allan Tubailah, Ibrahim Hammad, and Loay Al Kafafi, "Robot Cell Planning," In *Proc. the 2007 WASET*, vol. 20 pp. 250-255, 2007.
- [6] R. Bohlin, L. E. Kavraki, "Path Planning Using Lazy PRM," In *Proc. the 2000 IEEE International Conference on Robotics & Automation San Francisco*, 2000.
- [7] "Automatic Path Planning crash course," Fraunhofer-Chalmers research Centre, Gothenburg, Sweden, 2009.
- [8] V. MATA and A. TUBAILEH, "The machine layout problem in robot cells," *INT. J. PROD. RES.*, vol. 36, no. 5, pp. 1273-1292, 1998.
- [9] Marcus Andersson, "Effektiv simulering och analys av flexibla slangkomponenter," M.S. thesis, Dept. Product and Production Development, Chalmers University of Technology, Gothenburg, Sweden, 2008.
- [10] VINNOVA, the Swedish Governmental Agency for Innovation Systems 2007, MORE Program Projects Catalog, "Simulation and path planning for Flexible Materials," ISSN: 1650-3120, Sweden, 2007.
- [11] Johan S. Carlson, Rikard Söderberg, Robert Bohlin, Lars Lindkvist, and Tomas Hermansson, "Non-nominal path planning of assembly processes," In *Proc. the 2005 ASME International Mechanical Engineering Congress and exposition November 5-11, Orlando, FL*, 2005.
- [12] Johan Segeborn, Johan S. Carlson, Robert Bohlin, and Rikard Söderberg, "Geometry Design Supported by Minimizing and Visualizing Collision in Dynamic Packing," In *Proc. the 2007 WASET*, vol. 25 pp. 164-171, 2007.
- [13] Dandan Zhang, Liwei Qi, "Virtual engineering II, Optimal cell layout for industrial robots improves manufacturing productivity," *Special report dancing with the dragon, ABB review*, pp. 90-92, China, 2008.