

Effects of Variations in Generator Inputs for Small Signal Stability Studies of a Three Machine Nine Bus Network

Hemalan Nambier a/l Vijayan, Agileswari K. Ramasamy, Au Mau Teng and Syed Khaleel Ahmed

Abstract—Small signal stability causes small perturbations in the generator that can cause instability in the power network. It is generally known that small signal stability are directly related to the generator and load properties. This paper examines the effects of generator input variations on power system oscillations for a small signal stability study. Eigenvalues and eigenvectors are used to examine the stability of the power system. The dynamic power system's mathematical model is constructed and thus calculated using load flow and small signal stability toolbox on MATLAB. The power system model is based on a 3-machine 9-bus system that was modified to suit this study. In this paper, Participation Factors are a means to gauge the effects of variation in generation with other parameters on the network are also incorporated.

Keywords—Eigen-analysis, generation modeling, participation factor, small signal stability.

I. INTRODUCTION

THE stability of power system networks is an important aspect in reliability and security of power supply. Generally, generators experience oscillatory problems throughout its service life in system networks and can be risky to the system in terms of disrupting continuous power transfer to the grid. One such oscillatory problem is the small signal stability issue, which is caused by small perturbations in the system, which, occurs frequently in normal systems [1]. Unfortunately, its behaviour in relation with system parameters such as load and generation variations are not completely understood. A general method of small signal stability analysis uses the modal analysis method where investigation is done on the modes (eigenvalues) and states (electrical and mechanical parameters of a generator). Usually, modes can either be underdamped (unstable) or marginally stable. Specifically, analysis is done on the least damped mode (as in a case of instability of the system) to determine its type of oscillation, source of oscillation and its response to changes in system parameter values [2]. In this study, the participation factor concept is revisited and used for study on mode of the system. This paper is an investigation of the relevant system parameter modulations of a three machine nine bus network.

H. Nambier¹, Agileswari R.², A.M Teng³, S.K Ahmed⁴, are with the Department of Electronic and Communication Engineering, Universiti Tenaga Nasional, Jalan IKRAM-UNITEN, 43000 Kajang, Malaysia
¹hsnaken@yahoo.com, ²agileswari@uniten.edu.my, ³mtau@uniten.edu.my, ⁴syedkhaleel@uniten.edu.my.

The participation factors of the electrical parameters of the machine are used as an indication of the contribution of instability to the system [3]. Variations of generation are done on a the system as these parameters directly contribute to small signal stability causes in power systems. Varying the parameters causes changes in the participation factors which can be analyzed to determine which parameter and how it effects small signal stability. This study facilitates in optimizing system stability for maximum power transfer and optimal power system security.

II. MODELING

A. Eigenvalues and Eigenvectors

The Small Signal Stability analysis of an electrical power system is examined by the eigenvalues of the state matrix A . These eigenvalues may be either real or complex values. A real eigenvalue will represent a non-oscillatory mode, while a complex pair of eigenvalues corresponds to an oscillatory mode. The real part of complex eigenvalues provides the damping coefficient, while the imaginary part gives the oscillation frequency. The eigenvalues, λ of the state matrix are given by the non-trivial solutions of the equation (1).

$$\det[\mathbf{A} - \lambda\mathbf{I}] = 0 \quad (1)$$

The i^{th} right eigenvector satisfies

$$\mathbf{A}\mathbf{u}_i = \lambda_i\mathbf{u}_i \quad (2)$$

The i^{th} left eigenvector satisfies

$$\mathbf{v}_i\mathbf{A} = \lambda_i\mathbf{v}_i \quad (3)$$

The most general representation of state-space for linear systems are given in equations 2.4 and 2.5

$$\dot{\mathbf{x}}(t) = \mathbf{A}(t)\mathbf{x}(t) + \mathbf{B}(t)\mathbf{u}(t) \quad (4)$$

$$\mathbf{y}(t) = \mathbf{C}(t)\mathbf{x}(t) + \mathbf{D}(t)\mathbf{u}(t) \quad (5)$$

B. Participation Factors

Participation factors are non-dimensional and easy to compute. The trouble with using left and right eigenvectors independently is that they are dependent on units and scaling associated with the state variables. They are a fast way to determine possible candidate machines for damping control of unstable or lightly stable rotor angle oscillatory modes. Participation factors are a measure of the relative participation of the j^{th} eigenvalue (state variable) in the i^{th} mode, and vice

versa. The right eigenvector measures the activity of x in the i^{th} mode and left eigenvector weighs the contribution of this activity to the mode. The product of these P_{ji} , measures the net participation, as per equation 2.6. Participation factor is actually equal to the sensitivity of the eigenvalue λ_j to the diagonal element of a_{rs} of the state matrix A as in equation 2.7 [4]

$$p_{ji} = v_j(i)u_j(i) \quad (6)$$

$$\frac{\partial \lambda_j}{\partial A_{rs}} = v_j(r)u_j(s) \quad (7)$$

III. SIMULATION

The test system used in this investigation is the IEEE – 3 machine 9 bus test system as in Fig.1 with modifications so that the parameters of both left and right sides of the network mirror each other. The reason this test network was modified such, was so that the effect of variations on its generation could be significantly detected. The symmetrical distance of lines, and loads would help in indicating changes in dominant states as well as stability as the generation varies. For example, the parameters for line distance of bus 2-7 is equal to bus 3-9, while bus 7-5 is similar to bus 9-6, and so on. MATLAB toolbox was used to analyze this system by performing the small signal analysis. Small signal stability analysis is carried out by performing the following steps:-

- Loads the system data
- Performs load flow on the system, linearizes system equations and construct the matrices and finally the system state matrix A .
- Calculate system's eigenvalues, associated frequency and damping ratios.

The effect of generation input was analyzed by increasing the generation value of one machine methodically from 0%-150% of the original value. At each change in the generation value the state variables were re-calculated after running a load flow program and linearization of the system equation was performed and the state matrix A . Analysis of the system can then be carried out by acquiring the eigenvalues of the state matrix, A and the associated participation factors. The eigenvectors are then used check for stability of swinging characteristics of the system.

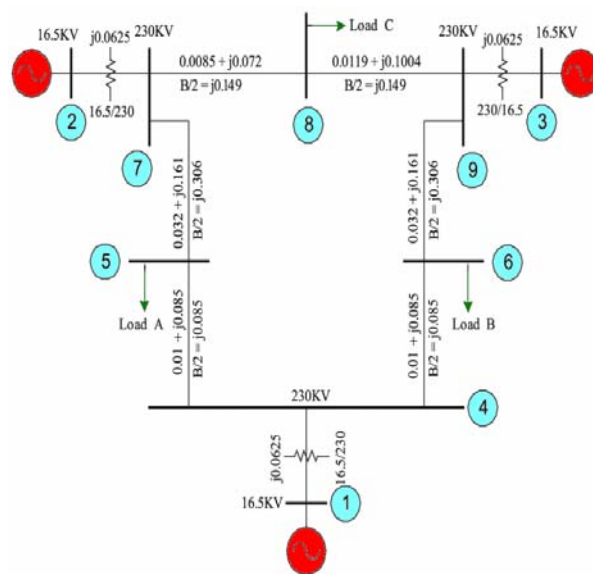

Fig. 1 The 3 machine 9 bus test case

IV. RESULTS & DISCUSSION

Table I shows the modes for the test system, its associated eigenvectors, the damping factor, frequency and the dominant state for that particular mode based on participation factors. Of the dominant states, only the electrical parameters are considered as they contribute to the rotational angle, δ and rotational speed, ω of the generators [5].

TABLE I
INCREMENT OF GENERATION INPUT VALUES

MODE	EIGENVECTORS	DAMPING FACTOR	FREQUENCY, Hz	DOMINANT STATES
1	-0.0024	1.0000	0	δ of Gen 1
2	0.0024	-1.0000	0	
3	-0.5126 - 0.8143i	0.5328	0.1296	Mechanical parameters Gen 2
4	-0.5126 + 0.8143i	0.5328	0.1296	
5	-0.5232 - 0.8388i	0.5292	0.1335	Mechanical parameters Gen 1
6	-0.5232 + 0.8388i	0.5292	0.1335	
7	-0.5418 - 1.0019i	0.4757	0.1595	Mechanical parameters Gen 2 & 3
8	-0.5418 + 1.0019i	0.4757	0.1595	
9	-3.2486	1.0000	0	Mechanical parameters Gen 2 & 3
10	-3.3935	1.0000	0	
11	-3.3950	1.0000	0	Mechanical parameters Gen 1
12	-0.1971 - 5.6748i	0.0347	0.9032	
13	-0.1971 + 5.6748i	0.0347	0.9032	ω of Gen 1
14	-0.2405 - 6.0558i	0.0397	0.9638	δ and ω of Gen 2 and 3
15	-0.2405 + 6.0558i	0.0397	0.9638	

16	-5.1393 - 7.8237i	0.5490	1.2452	Mechanical parameters Gen 2 & 3
17	-5.1393 + 7.8237i	0.5490	1.2452	
18	-5.1842 - 7.8690i	0.5502	1.2524	Mechanical parameters Gen 1
19	-5.1842 + 7.8690i	0.5502	1.2524	
20	-5.1891 - 7.8761i	0.5502	1.2535	Mechanical parameters Gen 2 & 3
21	-5.1891 + 7.8761i	0.5502	1.2535	

Machine 3's (machine connected to bus 3) generation output into the system is increased proportionally from 0% to 150%, the Table 2 shows the values of the generation which was used in the simulation. Each increment value of generation is then run through the program and its eigenvalues are displayed.

TABLE II
 INCREMENT OF GENERATION INPUT VALUES

Percentage Increase	Generation (pu)	Dominant State
0%	1.00 + j 0.3	ω_1
10%	1.10 + j 0.33	ω_1
20%	1.20 + j 0.36	ω_1
30%	1.30 + j 0.39	ω_1
40%	1.40 + j 0.42	ω_1
50%	1.50 + j 0.45	ω_1
60%	1.60 + j 0.48	ω_1
70%	1.70 + j 0.51	ω_1
80%	1.80 + j 0.54	ω_1
90%	1.90 + j 0.57	ω_1
100%	2.00 + j 0.60	ω_1
110%	2.10 + j 0.63	δ_3
120%	2.20 + j 0.66	δ_3
130%	2.30 + j 0.69	δ_3
140%	2.40 + j 0.72	δ_3
150%	2.50 + j 0.75	δ_3

The dominant states as shown in Table 2 are acquired by the participation factor analysis of the least damped mode of the entire system, i.e. mode 12/13. The modes of the entire system and their corresponding dominant states are shown in Table 1.

As only electrical parameters are significant for a small signal stability analysis, i.e. the rotational angle, δ and rotational speed, ω , a plot of the participation factors for mode 12/13 (least damped mode) of all three machines for the incremental increase in generation for machine 3 is made and shown in Fig. 2.

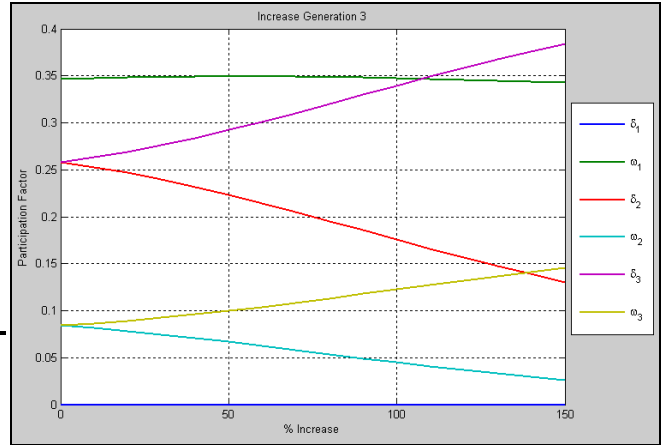

Fig. 2 Plot of participation factors of 3 machine parameters in network for 0% -150% increase in generation.

In Figure 2 above, each machines parameters of rotor angle and rotational speed participation factors are recorded. 0% increase denotes the original base case where rotational speed of machine 1 is the most influential. As the generation increases, machine 1's both parameters (angle and speed) remain fairly constant, this is because it is the slack bus of the system. The participation factors for rotor angle of machine 2 and machine 3 are opposing each other. As the generation output for machine 3 increases, the prominence of machine 2, or its influence in instability of the system reduced. Machine 3 becomes more influential in a possible cause of instability. This is also true for rotational speed of machine 2 and 3. The fact that rotor angle of machine 3 is most influential is the likeliness of lack of sufficient synchronizing torque. From 0% up to 100% of the simulation, it appears that rotational speed of machine 1, the reference, is most influential, this is caused by lack of sufficient damping. Utilizing the eigenvectors of the system, the degree angle and magnitude of each machine's rotational angle, δ is analyzed to for certain the swinging characteristics of the system. In an event of a small signal instability, generators are likely to swing against each other in certain patterns. Fig. 3-5 shows the swinging characteristics of all the three machines when the generation input for machine 3 is increased as per Table 1.

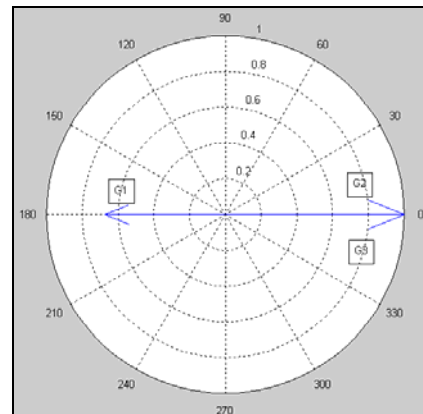

Fig. 3 Swinging at 0% increase in base generation of machine 3

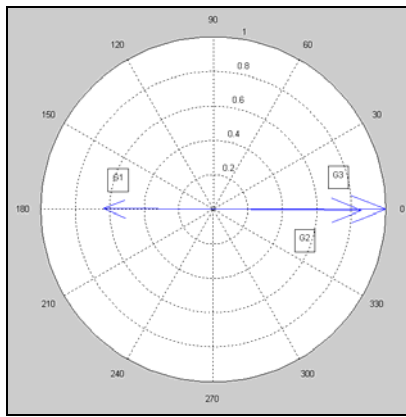

Fig. 4 Swinging at 100% increase in base generation of machine 3

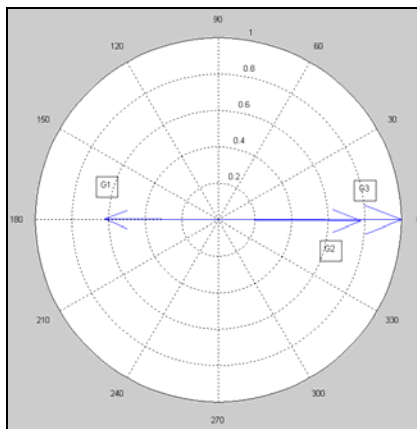

Fig. 5 Swinging at 150% increase in base generation of machine 3

Therefore, from these four compass plots, which was derived from the right eigenvector of the system, shows how generator 1 is swinging against generator 2 and generator 3. Overall, there is no effect in change of swinging direction when there is an increase of the generator output. Nevertheless, it is observable that the magnitude of activity of generator 1 and 3 remains fairly constant but the magnitude of generator 2's activity in the system is reducing as the generation of machine 3 is increasing. This is relative to what the graphical output showed in Fig. 2, as both machines 2 and 3 are on opposite ends of the network, although they're swinging in the same direction they magnitudes differ. This type of oscillation is of inter area mode oscillation, where one group of generators are swinging against another group [6].

V. CONCLUSION

A small signal stability investigation for variations in generation inputs was carried out with aid of participation factor analysis. It can be concluded that generation input of a system does affect the stability of a network when experiencing a small signal disturbance. The concluding results from this simulation can be summarized as follows.

- An increase of generation capacity can cause the machine to lose synchronism with the network and affect its rotor angle, making it more influential in instability
- Generation variations almost never effect the swinging characteristics of a three machine nine bus network

The outcomes of this paper is that a successful study of the behaviour of power system networks, when subjected to small signal stability for a three machine nine bus test case was performed and the identification of crucial parameters, such as generation that can effect small signal stability of a power system network which is also inclusive of the networks swinging characteristics.

ACKNOWLEDGMENT

This work was supported in part by MOHE (Ministry of Higher Education, Malaysia) with project code 01090003 FRGS

REFERENCES

- [1] Kundur, P. et al. "Definition and Classification of Power System Stability" IEEE Transactions On Power Systems, 2004, Vol. 19, pp. 1387-1401
- [2] Richard G. Farmer "Power System Dynamics and Stability" Taylor & Francis Group, LLC, 2006
- [3] Hsu, Yuan-Yih et al. "Identification of optimum location for stabiliser applications using participation factors" IEE Proceedings on Generation, Transmission and Distribution, 1987, Vol. 134, pp. 238-244
- [4] Rodriguez, O. et al. "A Comparative Analysis of Methodologies for the Representation of Nonlinear Oscillations in Dynamic Systems" IEEE Lausanne Power Tech, 2007, pp. 172-177
- [5] Graham Rogers, "Power System Oscillations", Kluwer Academic Publishers, USA, 2000.
- [6] Kundur, P. "Power System Stability and Control" Electric Power Research Institute, McGraw-Hill, Inc. 1994