

# Mobility Management Architecture for Transport System

DaeWon Lee and HeonChang Yu

**Abstract**—Next generation wireless/mobile networks will be IP based cellular networks integrating the internet with cellular networks. In this paper, we propose a new architecture for a high speed transport system and a mobile management protocol for mobile internet users in a transport system. Existing mobility management protocols (MIPv6, HMIPv6) do not consider real world fast moving wireless hosts (e.g. passengers in a train). For this reason, we define a virtual organization (VO) and proposed the VO architecture for the transport system. We also classify mobility as VO mobility (intra VO) and macro mobility (inter VO). Handoffs in VO are locally managed and transparent to the CH while macro mobility is managed with Mobile IPv6. And, from the features of the transport system, such as fixed route and steady speed, we deduce the movement route and the handoff disruption time of each handoff. To reduce packet loss during handoff disruption time, we propose pre-registration scheme using pre-registration. Moreover, the proposed protocol can eliminate unnecessary binding updates resulting from sequence movement at high speed. The performance evaluations demonstrate our proposed protocol has a good performance at transport system environment. Our proposed protocol can be applied to the usage of wireless internet on the train, subway, and high speed train.

**Keywords**—Binding update, HMIPv6, Packet loss, Transport system, Virtual organization

## I. INTRODUCTION

VARIOUS factors have completely changed the role of handoff management, which faces the challenge of adaptation to heterogeneous and multi parametric environments. These factors include the explosion of mobile data communications, the emergence of multi technology environments with diverse capabilities, the integration of such environments at both node and network sides, and the great variety of offered enduser services. Next generation wireless/mobile networks will be IP based cellular networks integrating with the internet. Mobile IPv6 (MIPv6) was designed by the IETF to manage mobile host movement between wireless IPv6 networks. MIPv6 proposes simple and scalable macro/micro mobility management. Using MIPv6, nodes are able to access wireless IPv6 networks without changing their IP address. However, if the mobile host (MH) moves frequently, MIPv6 experiences high handoff latency and high signaling costs in updating the MH's location [1]. Thus, many mobility management protocols [2, 3, 4, 5, 6] have been proposed to

DaeWon Lee and HeonChang Yu is with the Department of Computer Science and Education, Korea University, Seoul, Korea (e-mail: {daelee, yuhc}@comedu.korea.ac.kr).

improve handoff performance and reduce signaling overhead. Conventional protocols separate micro mobility (intra domain) from macro mobility (inter domain) management. However, these protocols have no consideration of practical real world moving hosts. In this paper we are focused on transport system mobility that happens in real world. Based on route movement information of a transport system, we can deduce the movement route. By deduction, we construct a virtual organization (VO), which provides better service and connectivity to MHs in transport systems. By employing a special entity, using a virtual mobility anchor point (VMAP) to act as a gateway to the VO, all MHs within the VO can achieve global connectivity independent of their capabilities. The VMAP keeps a managed MH in transport system and multicasts packets to the current domain of the transport system and the new domain that the transport system moves on. We also classify VO mobility (intra VO) and macro mobility (inter VO). And handoffs in a VO are locally managed and transparent to the corresponding host (CH) while macro mobility is managed with Mobile IPv6. And, to reduce packet loss and handoff disruption time, we propose pre-registration scheme using pre-registration. Using the transport system's fixed route and steady speed, we deduce the handoff disruption time of each handoff and request pre-registration that register MH's suffix to all MAPs of the VO. And, through performance evaluations, we prove that our proposed protocol reduces signaling cost and packet loss by using proposed pre-registration scheme for fast moving wireless hosts.

This paper is organized as follows: section 2 presents related works about mobile IP protocols. Section 3 explains virtual organization (VO). Section 4 describes our proposed protocol based on VO. Section 5 shows comparison between the proposed protocol and HMIPv6 by performance analysis. Finally, section 6 concludes this paper.

## II. RELATED WORKS

The Mobile IPv6 (MIPv6) protocol is specified by the IETF IP Routing for the wireless/mobile hosts working group [1]. MIPv6 supports mobility of IP hosts by allowing them to make use of two addresses: a home address (HoA) which represents the fixed address of the node and a care of address (CoA) which changes with the IP subnet the mobile node is currently attached. But MIPv6 has several well known weaknesses such as handoff latency and signaling overhead, which have led to macro/micro mobility, FMIPv6, and BETH [2, 3, 4, 5, 6]. Thus,

many mobility management protocols have been proposed to improve handoff performance and reduce signaling overhead.

Hierarchical mobile IPv6 (HMIPv6) is an optional extension to MIPv6 and supports an n-level hierarchy [2]. This protocol is a localized mobility management proposal that aims to reduce the signaling overhead due to user mobility. Mobility management can be classified into micro mobility (intra domain) and macro mobility (inter domain) management. Micro mobility is handled by a mobility anchor point (MAP). Mobility between separate MAP domains is handled by MIPv6. Fig. 1 shows n-level hierarchical mobility management architecture.

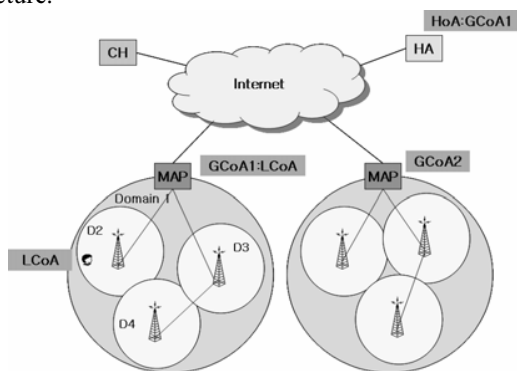

Fig. 1 N-level hierarchical mobility management architecture

Using n-level hierarchical architecture has at least two advantages. First, it improves handoff performance, since micro handoffs are performed locally. This increases the handoff speed and minimizes the loss of packets that may occur during transitions. Second, it significantly reduces the mobility management signaling load on the internet since the signaling messages corresponding to micro moves do not cross the whole internet but stay confined to the subnet [2].

And NTT DoCoMo proposed HMIP-Bv6 that extends HMIPv6 with buffering mechanism. It presents an IP based mobility management scheme that enhances the mobility of mobile hosts in 4G systems. There are three challenges of HMIP-Bv6: multiple interface management, active state mobility management, and dormant state mobility management. HMIP-Bv6 presents multiple interface management for multiple kinds of link layers. And, HMIP-Bv6 presents a mobility management scheme that divides active states and dormant states of the MH. In an active state, they add buffering function to the MAP. If the CH sends packets to MHs, the packets are buffered in the MAP to prevent packet loss during handoffs. In a dormant state, they use a paging scheme to conserve power of the MHs and reduce the number of control signals keeping their sessions. There are various benefits of HMIP-Bv6 [7]: reduced transmission power, packet loss during handoffs, and control signals.

However, these protocols have no consideration of practical real world moving hosts. Laptop users access wireless internet in a fixed place such as a home, school, library, etc. And pedestrians using a PDA cannot move and use the wireless internet at the same time. Usually, they stop walking to access

the wireless internet, and then start walking again. These examples only refer to the usage of wireless internet, not movement and usage of wireless internet at the same time. The cases of movement while using wireless internet are accessing wireless internet in moving transport systems such as the automobile, train, subway, and high speed train (eg. TGV). The transport system provides a place to sit down and use a laptop computer. There are many MHs in a train. They join and leave continually when they change their attachment to the internet. In this case, if a MH operates under MIP or MIPv6, MIP or MIPv6 capabilities would not be able to guarantee session continuity for each node. Consider the case where link layer handoff is via a satellite link and the nodes have no radio access capabilities to perform the necessary handoffs. It is not efficient to expect each node to individually manage its mobility. Thus, the IETF proposed network mobility (NEMO) [8, 9, 10]. NEMO considers only group movement, and doesn't consider movement on a fixed route. For example, a train departs from subnet X to Y and it passes subnet A, B, C, to subnet Y. If this route information is managed, MHs perform faster handoff and keep their sessions continuously.

### III. VIRTUAL ORGANIZATION

#### A. Virtual Organization and VO Mobility

There are a large number of MHs requiring global connectivity in transport systems such as ships, aircrafts and trains. Although 802.16/ WIBRO is proposed, mobility management protocols [2, 3, 4, 5, 6] do not consider usage of wireless internet in transport systems. Even if MHs have random mobility, transport systems are moving on a determined route and the MHs are in the transport system. Generally, transport systems have a fixed route to the destination. There are two factors for moving with a transport system. One is the steady speed of the transport system and the other is its fixed route. Based on the steady speed and fixed route, transport system's movement route can be deduced. By deduction, we construct a virtual organization (VO) that provides better service and connectivity to MHs in transport systems. In this paper, we define the virtual organization as follows:

#### Definition 1 Virtual Organization (VO)

A virtual organization is the fixed route of the transport system and consists of many domains. ■

Thus, the VO is wireless computing environment that transport systems move on a fixed route such as automobile, train, subway, train express (TGV), etc. From user's point of view, each of them stays fixed location but their location keeps moving within the VO. And, we separate VO mobility (intra VO) from macro mobility management using VO. We define a VO as the highest level of hierarchical architecture. VO mobility does not require binding update signaling to HA. It manages by VMAP, and minimizes handoff delay on high speed movement environment. Macro mobility requires

binding update signaling to HA as HMIPv6. Fig. 2 shows the VO and the macro mobility according to movement of the MH.

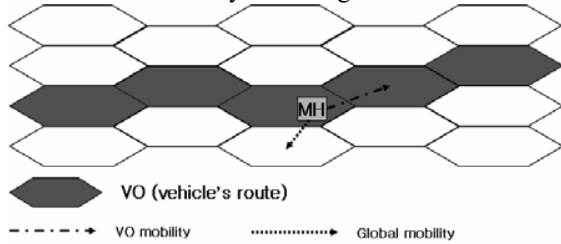

Fig. 2 VO and macro mobility

### B. Design of Virtual Organization

We define a VO as the highest level and we extend [2]'s hierarchical architecture. We propose a VMAP (virtual mobility anchor point) for extending hierarchical architecture. The VMAP is a set of MAPs that makes a VO, and also it is logically on MAPs. Fig. 3 shows schematic representation of VO and protocol stack, and assumes the use of IPv6.

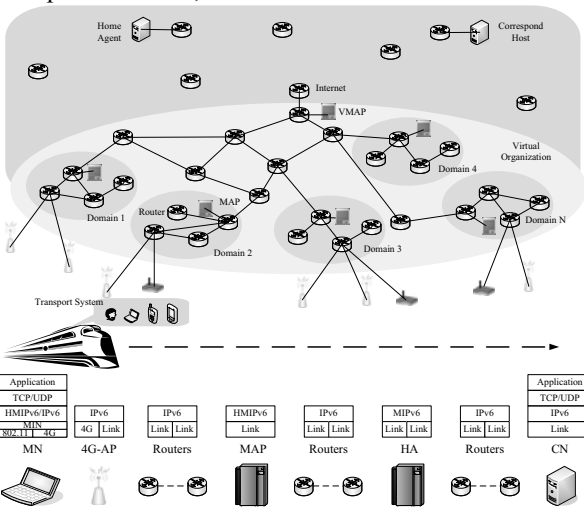

Fig. 3 Schematic representation of VO and protocol stack

## IV. PROPOSED PROTOCOL

### A. Protocol Overview

In our proposed hierarchical structure, since a MH moves into a transport system, the MH moves as the transport system's moves. When the MH attaches to a new network, it is required to register with the MAP serving the network domain. If the domain belongs in the VO, the MAP is required to register with the VMAP serving the VO. After registration, the VMAP intercepts all packets addressed to the MH and tunnels them to the MAP, and the MAP tunnels them to the MH. If the MH moves into a different domain in a VO, new global address (GCoA) binding with the VMAP is required. Usually, the MH will use the VMAP's address as the GCoA and LCoA can be formed according to methods described in [2, 11]. After these addresses are formed, the MH sends a regular MIPv6 binding update to the MAP which binds the MH's GCoA to the LCoA, and the MAP sends an extended MIPv6 binding update to the VMAP which binds the MH's virtual care of address (VCoA) to the GCoA. In response, the MAP sends a binding

acknowledgement (BACK) to the MH, and the VMAP sends a BACK to the MAP. Furthermore, the MH must also register its new LCoA with its HA by sending another binding update that binds the HoA to the VCoA. Finally, it may send a binding update to its current corresponding nodes, specifying the binding between its HoA and the newly acquired VCoA.

### B. Registration Phase

MH gets several CoAs (LCoA, GCoA, VCoA) and registers each of them with VMAP, MAP, HA, CH. This registration phase differs in VO mobility and macro mobility. Fig. 4 and fig. 5 show the registration phase and its call-flow. If the MH moves anywhere in VO, the packet is delivered to VMAP that is the highest hierarchy, and it is directly forwarded to MH. And BUs are only sent outside the VO (HA and CH), when MH moves out the VO. Therefore, our protocol using VMAP reduces signaling overhead on macro mobility.

```

1 ##Pseudo Code of Registration
2
3 while (MH receives router advertisement message)
4   (
5     if (R-bit set) then
6       request registration to MH ## get LCoA
7     else
8       if (R-bit and O-bit set) then
9         request registration to MH ## get LCoA
10        request registration to MAP ## mapping GCoA : LCoA
11        request registration to VMAP ## mapping VCoA : LCoA
12        send binding updates to HA/CH ## mapping HoA : VCoA
13      else
14        perform MIPv6 registration phase
15      endif
16    endif
17  )
18  endif
19  )
20  )
21 endwhile
    
```

Fig. 4 Registration phase

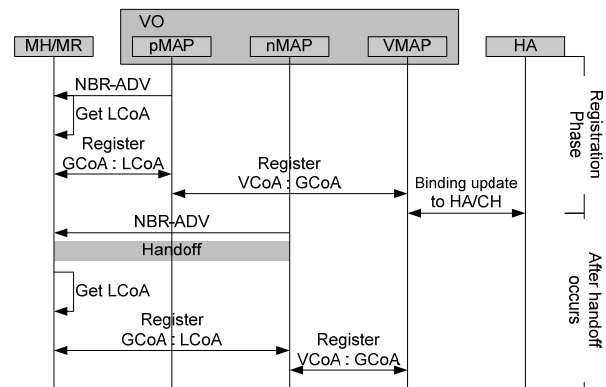

Fig. 5 Call-flow of the registration phase

### C. Virtual Organization and Virtual Mobility Anchor Point Discovery

To perform the registration operation in section IV. B, a MH needs the following information:

- the prefix of the domain
- the depth of the hierarchy
- the network prefix of MAP
- the domain in VO or Not

This information is advertised by a new option used that we extended in the Router Advertisement message of the IPv6 Neighbor Discovery [12]. Fig. 6 shows extended router advertisement message format.

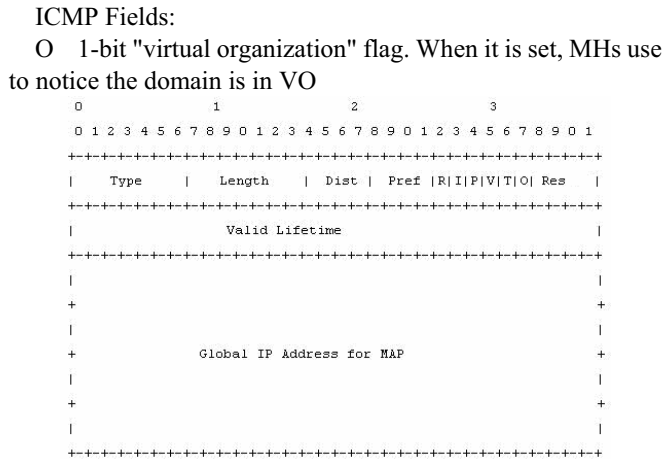

Fig. 6 Extended router advertisement message format

D. Packet Delivery

When a CH sends packets to MH, the CH uses its VCoA. VMAP intercepts packets and encapsulates packets to MH's GCoA. Then MAP intercepts packets and encapsulates packets to MH's LCoA. Then, packets are forwarded to MH.

When a MH sends packet, it sets the source field of IP header to its LCoA. And using home address option, it specifies its home address. Fig. 7 shows the call-flow of packet delivery.

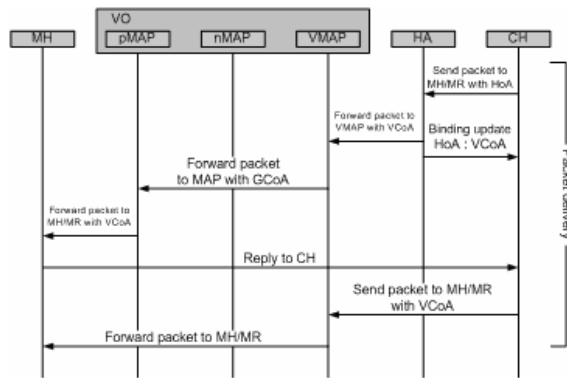

Fig. 7 Call-flow of packet delivery

E. Pre-registration Scheme

Our proposed pre-registration scheme addressed to deliver packets to an MH as soon as its attachment is detected by the new AR. In this system, the arrival time to the destination is easily calculated, because the transport system has fixed route and steady speed. Thus we proposed pre-registration mechanism at VMAP. When the MH enters into the VO, the VMAP deduces the handoff disruption time of each handoff and requests pre-registration that registers MH's suffix to all MAPs of the VO. And the VMAP sets multicasting timer up before each handoff disruption time. If packets arrive to the VMAP during deduced handoff disruption time, the VMAP buffers these packets. Then the VMAP forwards them to pMAP and nMAP before finishing registration. Fig. 8 shows the condition of packet multicast by movement of transport system. Fig. 9 shows the call-flow of pre-registration.

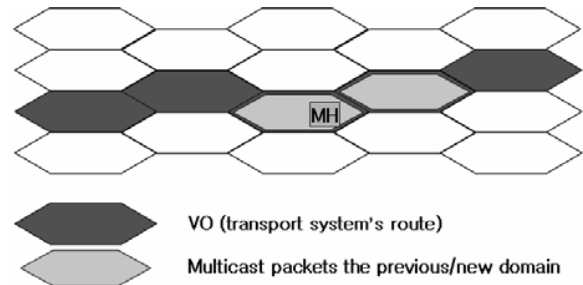

Fig. 8 The condition of packet multicast by movement of transport system

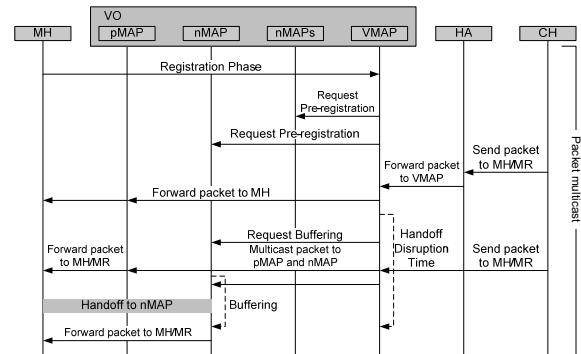

Fig. 9 Call-flow of pre-registration

Proposed protocol reduces BU at VO mobility. It has better performance with VO that consists of many domains. Also proposed protocol reduces handoff packet loss and handoff disruption time using pre-registration scheme.

V. SIGNALING COST FUNCTION

We will analyze signaling costs of Mobile IPv6, HMIPv6, and proposed protocol then compare one another. An analysis is done for a MN which is located in a VO since signaling costs in a HA are the same for Mobile IPv6, HMIPv6, and proposed protocol.

Following is the notations for analysis:

$C_{i-j}$  is the registration cost when a MN moves from subnet j to subnet i.

$\prod_i$  is the location probability of a user in subnet i.

$\lambda$  is the incoming data rate for a MN

$R_r$  is the refresh rate that a MN renews its location.

$t_i$  is the time duration that a MN stays in a PA.

$C_{AR-HA}$  is the registration cost between a AR and a HA.

$C_{AR-MAP}$  is the registration cost between a AR and a MAP.

$C_{MAP-VMAP}$  is the registration cost between a MAP and a VMAP.

A. Mobile IPv6

In MIPv6, signaling costs consist of only registration costs, such that the first term is the average registration costs with a

new AR and the second term is the average registration costs with MN's HA in equation (1). Signaling costs in Mobile IPv6 depend on the distance between the AR and the HA. Therefore, if the distance between the FA and the HA is fixed, signaling costs are constant regardless of the mobility and call arrival pattern.

$$C_{MIP} = \sum_{i=1}^N \left\{ \sum_{j=1}^N \prod_i C_{j-i} + \prod_i C_{AR-HA} \right\} R_r t_i \quad (1)$$

### B. Hierarchical Mobile IPv6

In HMIPv6, signaling costs only depend on registration costs like MIPv6, but it is deployed on a hierarchical architecture. There are two independent events as follows: the first registration in a new domain, and the subsequent registration within the same domain. The first registration costs in a new RA are derived in equation (2).

$$C_{init} = \prod_i \{ C_{j-i} + C_{AR-MAP} + C_{MAP-HA} \} \quad (2)$$

, where subnets k and j are located in different domains.

The subsequent registration costs are derived in equation (3). The first term is the registration cost from a MN to its FA and the second term is the registration cost from the AR to its MAP.

$$C_{HMIP} = \sum_{i=1}^N \left\{ \sum_{j=1}^N \prod_i C_{j-i} + \prod_i C_{AR-MAP} + \prod_i C_{MAP-HA} \right\} R_r t_i \quad (3)$$

### C. Proposed Protocol

Signaling costs in proposed protocol consist of registration and pre-registration costs. There are three independent events as follows: (i) the first registration in a new VO, (ii) the subsequent registration within the same domain, and (iii) the first registration with pre-registration scheme in a new VO.

The first registration cost in a new VO is given by equation (4).

$$C_{init} = \prod_i \{ C_{j-i} + C_{AR-MAP} + C_{MAP-VMAP} + C_{MAP-HA} \} \quad (4)$$

, where subnets k and j are located in different VOs.

The first term in equation (4) is the average registration cost for a MN's movement from a subnet k to j and the second term is the average registration cost from an AR to its MAP. The third term in equation (4) is the registration cost from the MAP to VO's VMAP, and the fourth term is the registration cost from the VMAP to MH's HA. Note that this registration cost only happens when a MH moves into a new VO.

The subsequent registration costs within same VO are

$$C_{proposed} = \sum_{i=1}^N \left\{ \sum_{j=1}^N \prod_i C_{j-i} + \prod_i C_{AR-MAP} + \prod_i C_{MAP-VMAP} \right\} R_r t_i \quad (5)$$

The first term in equation (5) is the average registration cost for a MN's movement from subnet j to i and the second term is the registration costs from the AR to its MAP, and the third term is the registration cost from the MAP to VO's VMAP.

The first registration cost with pre-registration scheme in a new VO are given by

$$C_{init\_pre} = \prod_i \{ C_{j-i} + C_{AR-MAP} + C_{MAP-VMAP} + C_{MAP-HA} + \lambda t_i E[pre - registrationCost] \} \quad (6)$$

, where subnets k and j are located in different VOs.

The equation (6) is same as (4) except the last term. The last term in equation (6) is average pre-registration cost in VO. And the registration costs with pre-registration scheme within the same VO are same as equation (5).

### D. Signaling Cost Evaluation

To simplify the evaluation of signaling costs for MIPv6, HMIPv6, proposed protocol and proposed protocol with pre-registration, we assume that a MH has registered with its HA previously. The initial registration costs of HMIPv6, proposed protocol and proposed protocol with pre-registration, i.e., equations (2), (4) and (6), will be excluded in evaluation. Therefore, equations (1), (3), and (5) will be used for analyzing signaling costs for MIPv6, HMIPv6, proposed protocol and proposed protocol with pre-registration, respectively. The parameters used for the analysis are tabulated in table 1.

TABLE 1. PARAMETER SETTINGS

$\lambda$	$R_r$	$t_i$
0.0008	0.03-0.05	10-1000

Fig. 10 shows how the total signaling costs are affected by the distance between HA and AR in same domain. As a MH is distant from its HA, signaling costs are much affected in MIPv6. Signaling costs increase linearly as the distance between the HA and the AR increases in fig. 10. Since HMIPv6 and proposed protocol separate micro mobility from macro mobility, registration costs do not propagate to its HA while a MH is in the same domain. Signaling costs in HMIPv6 and proposed protocol are steady and do not change in the same domain.

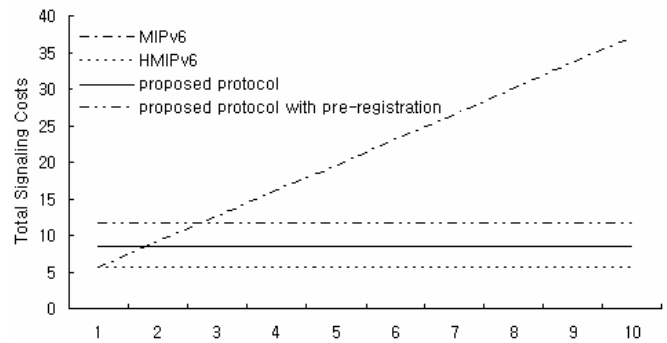

Fig. 10 Total signaling in a domain

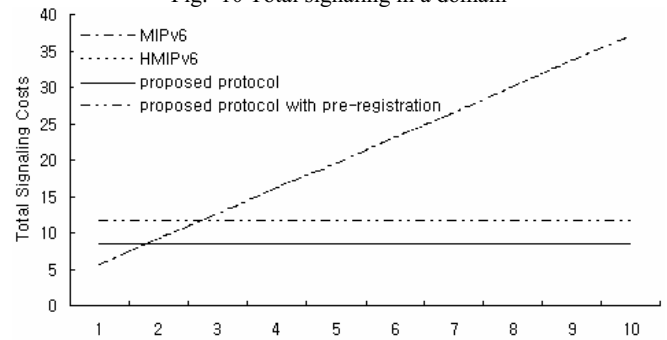

Fig. 11 Total signaling in a VO

Fig. 11 shows how the total signaling costs are affected by the distance between HA and AR in different domains within a VO. Signaling costs of MIPv6 and HMIPv6 are same. Because of the handoff between domains, HMIPv6 must perform registration to the its HA. Signaling costs in proposed protocol are steady and do not change in the same VO.

Proposed protocol has more signaling cost than HMIPv6 in fig. 10, but proposed protocol has less signaling costs in fig. 11. These results show that proposed protocol is suitable for inter domain handoff and fast movement.

Fig. 12 shows the effect of the call to mobility ratio (CMR) on total signaling cost. Similar to the performance analysis in the PCS network [14, 15], the CMR denotes the ratio of the session arrival rate to the BU rate. It can be represented as the ratio of packet arrival rate to the average subnet residence time, i.e.,  $CMR = \lambda_{\alpha} t_i$  from fig. 12, the proposed protocol has better performance compared to HMIPv6 when the CMR value is large. This is because the proposed protocol requires large signaling costs for constructing the VO at initial states. The proposed protocol does not require location update to the HA after constructing the VO.

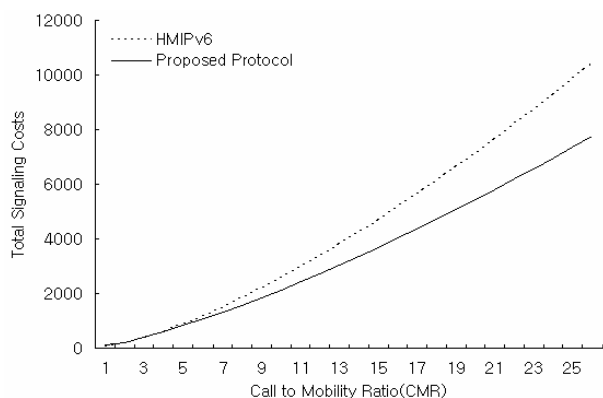

Fig. 12 Effect of the call to mobility ratio on total signaling cost

## VI. CONCLUSION

In this paper, we propose a new architecture for high speed transport systems and a mobile management protocol for mobile internet users in transport systems. The proposed architecture has several advantages and provides excellent solutions to the problems raised by mobility and wireless environments. It could be using transport systems: automobile, train, subway, train express (TGV), etc. Thus, we define the transport system as a virtual organization (VO) and establish a fixed route transport system to the VO. We also classify mobility into VO mobility (intra VO) and macro mobility (inter VO). The handoffs in VO are locally managed and transparent to the CH while macro mobility is managed with Mobile IPv6. From the features of the transport system, such as fixed route and steady speed, we deduce the movement route and the handoff disruption time of each handoff. To reduce packet loss during handoff disruption time, we propose pre-registration scheme using pre-registration that registers MH's suffix to all MAPs of the VO at initial state. Moreover, the proposed

protocol can eliminate unnecessary binding updates resulting from periodic movement at high speed. The performance evaluations have demonstrated the benefits of our proposed mechanisms. Our protocol has two advantages. First, it reduces the signaling overhead from BU on internet since the signaling messages corresponding to local moves do not cross the whole internet. Second, it reduces the packet loss by using proposed pre-registration scheme. Our proposed protocol can be applied to the usage of wireless internet on the train, subway, and high speed train (eg. TGV). In the future, we plan to implement these mechanisms and measure the performance of the real system. Further, we will discuss the issues of multiple transport system and multiple VMAPs and supporting a vertical handoff on the proposed architecture.

## REFERENCES

- [1] Johnson, D., Perkins, C., and J. Arkko, "Mobility Support in IPv6", RFC 3775, June 2004.
- [2] H. Soliman, F. Castellucia, K.E. Malki, and L. Bellier, "Hierarchical mobile IPv6 mobility management (HMIPv6)", in Internet Engineering Task Force, draft-ietf-mipshop-hmipv6-01.txt, 2004.
- [3] R. Ramjee, T. La Porta, S. Thuel, K. Varadhan, L. Salgarelli, "HAWAII: a domain-based approach for supporting mobility in widearea wireless networks", in IEEE/ACM Trans. Networking, Vol. 10, June 2002, pp. 396-410.
- [4] A. T. Campbell, J. Gomez, S. Kim, Z. Turanyi, C-Y. Wan, A. Valko, "Cellular IP", in Internet Engineering Task Force, draft-ietf-mobileip-cellularip-00.txt, January 2000.
- [5] C. Williams, "Localized Mobility Management Requirements", in Internet Engineering Task Force draft-ietf-mobileip-lmm-requirements -04.txt, October 2003.
- [6] Koodli, R., "Fast Handovers for Mobile IPv6", in Internet Engineering Task Force, (work in progress), draft-ietf-mipshop-fast-mipv6-03, October 2004.
- [7] Ichiro Okajima, Masahiro Inoue, Koji Omae, Hideaki Takahashi, and Narumi Umeda, "IP-based Mobility Management Technology", in NTT DoCoMo Technical Journal Vol.5 No.2, September 2003, pp 47-54.
- [8] Petrescu A., Olivereau A., Janneteau C., Lach H-Y., "Threats for Basic Network Mobility Support (NEMO threats)", in Internet Engineering Task Force, (work in progress), draft-petrescunemo-threats-01.txt, January 2004.
- [9] Devarapalli V., Wakikawa R., Petrescu A., Thubert P. "NEMO Basic Support Protocol", in Internet Engineering Task Force, (work in progress), draft-ietf-nemo-basic-support-02.txt, December 2003.
- [10] Ernst T., "Network Mobility Support Goals and Requirements", in Internet Engineering Task Force, (work in progress), draft-ietf-nemo-requirements-02.txt, Feb. 2004.
- [11] S. Thomson and T.Narten. "IPv6 Stateless Address Autoconfiguration", in RFC 2462, December 1998.
- [12] Narten, T., Nordmark, E., and Simpson, W., "Neighbor Discovery for IP Version6. (IPv6)", in RFC 2461, December 1998.
- [13] R. Chakravorty and I. Pratt. "Performance issues with general packet radio service", in Journal of Communications and Networks, 4(2), December 2002.
- [14] A. Stephane and A. H. Aghvami, "Fast handover schemes for future wireless IP networks: a proposal and analysis", in Proc. IEEE 53rd Vehicular Technology Conf., 2001, pp. 2046-2050.
- [15] Y. Wang, W. Chen, and J.S.M. Ho, "Performance Analysis of Mobile IP Extended with Routing Agents", in Technical Report 97-CSE-13, Southern Methodist Univ., 1997.

**DaeWon Lee** received his B.E. degree in Electrical Engineering from SoonChun-Hyang University and M.E. degree in Computer Science Education from Korea University, Korea, in 2001 and 2003, respectively. He is currently a Ph.D. candidate in Computer Science Education from Korea University. His research interests are in Mobile computing, Distributed systems, and Grid Computing.

**HeonChang Yu** received his B.S., M.S. and Ph.D. degrees in Computer Science from Korea University, Seoul, in 1989, 1991 and 1994, respectively. He is currently a Professor in the Department of Computer Science Education at Korea University in Ko-rea. He was a Visiting Professor at Georgia Institute of Technology in 2004 and a Vice Dean at College of Education of Korea University in 2005. His research interests are in Grid computing, Distributed computing and Fault-tolerant systems.