

# Fractal Analysis on Human Colonic Pressure Activities based on the Box-counting Method

Rongguo Yan, Guozheng Yan, Banghua Yang

**Abstract**—The colonic tissue is a complicated dynamic system and the colonic activities it generates are composed of irregular segmental waves, which are referred to as erratic fluctuations or spikes. They are also highly irregular with subunit fractal structure. The traditional time-frequency domain statistics like the averaged amplitude, the motility index and the power spectrum, etc. are insufficient to describe such fluctuations. Thus the fractal box-counting dimension is proposed and the fractal scaling behaviors of the human colonic pressure activities under the physiological conditions are studied. It is shown that the dimension of the resting activity is smaller than that of the normal one, whereas the clipped version, which corresponds to the activity of the constipation patient, shows with higher fractal dimension. It may indicate a practical application to assess the colonic motility, which is often indicated by the colonic pressure activity.

**Keywords**—Colonic pressure activity, erratic fluctuations, fractal dimension and spikes.

## I. INTRODUCTION

Under the normal physiological conditions, the accessibility of the large intestine by traditional manometry, i.e. water-infused colonic manometry, is hard. Consequently human colonic pressure activities under these conditions are still relatively unknown; and earlier diagnosis and studying relating to them are largely indirect and inadequate. However, with the development of new technology of micro-electro-mechanical system (MEMS) in recent years, e.g. a telemetrically measuring capsule for gastrointestinal diagnosis developed in our institute [1]–[5], it is possible to know the hidden dynamic properties of the colonic pressure activities. In the paper, we mainly discuss the fractal scaling behaviors of the fluctuations of the colonic pressure activities in nonlinear analysis rather than the traditional time-frequency domain statistics since these statistics show with limitations in clinical application.

As we know, many physiological or morphophysiological anatomies exhibit fractal dynamics, even altering with disease and aging [6]. Also in the digestive system, there are such fractals. The small intestine is such an example, whose inside

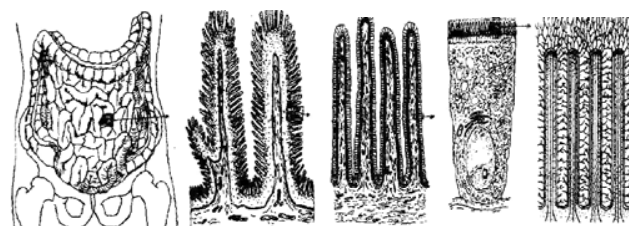

Fig.1. Fractal structure of the small intestine right down to the microscopic level: flexures, plicae, villi and microvilli surface exhibits a finger-like structure, and each successive microscopic level of magnification reveals the presence of a similar kind of structure: flexures, plicae, villi, microvilli (see Fig.1). Such fractal branches or folds greatly amplify the surface area available for absorption of chyme in the intestine [7,8].

## II. SUBJECTS AND METHODS

### A. The Overview of the Diagnosis System [1]–[5]

The colonic pressure activities were measured by using a capsule-like mini-robot system invented for gastrointestinal diagnosis in our institute in the past few years (see Fig.2). The four main components of the diagnosis system are: 1) an interventional telemetric capsule, which can perform data acquisition of physiological parameters within the GI tract under the normal physiological conditions; 2) an in-vitro pocket data logger, which can be mounted around the waist of the person and receive parameters from the capsule; 3) an ultrasonic locating unit, which performs detecting where the capsule is in the GI tract; and 4) an in-vitro data processing station, which is composed of a computer to download the acquired data from the pocket data logger via universal RS-232 interface and finally process them under the instruction and guidance of a doctor.

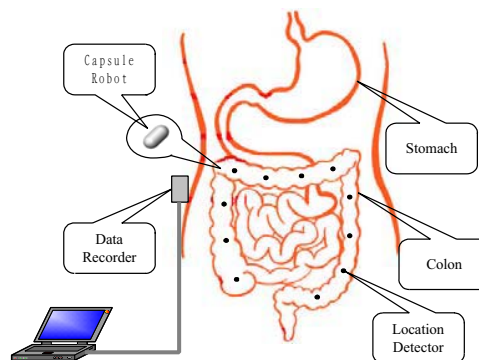

Fig.2. The diagnosis system for the GI tract

Manuscript received November 17, 2005. This work was supported by the National Natural Science Foundation of China, No.30270382; High Technology Research and Development Program of China, No. 04AA404013.

Rongguo Yan, Guozheng Yan, and Banghua Yang are with Institute of Medical Precision Engineering and Intelligent Micro-system, Shanghai Jiaotong University, Shanghai 200240, China. The corresponding author is Rongguo Yan, phone: 086-021-34201435; fax:086-021-34201434; email: yanrongguo@sjtu.edu.cn.

Fig.3 shows the schematic diagram of the telemetric capsule, the core of the diagnosis system, whose outline looks like a little bigger pharmaceutical pill with 21.1mm length, 10.0mm diameter and 2.9gram weight. It is primarily composed of physiological parameter sensitive sensors (e.g. pressure etc.); a signal-processing unit (sampling & A/D); a signal-transmitting unit, a power supply (battery cells) and a power management unit. The main function of the capsule is to perform sampling the physiological parameters within the GI tract, do signal processing, such as A/D converting, signal amplifying, communicating with the RF transceiver, and finally transmits the data modulated outside for receiving and saving through a loop antenna within the signal-transmitting unit by the in-vitro pocket data logger. The power all chips needed are supplied by the battery cells and distributed by the power management unit.

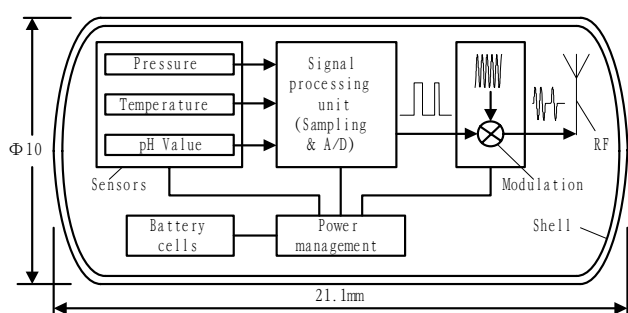

Fig.3. The schematic diagram of the telemetric capsule

The sampling rate of the system is about 0.83Hz (that is, a sample every 1.2 seconds). The sampling is more than adequate to measure motility signals that, in humans, lie in the range from 1 cycle per minute (cpm) to 12 cpm (0.016Hz to 0.2Hz).

### B. Clinical experiment

After the subject had swallowed the capsule with a cup of water, it began its "tour" from the mouth to the anus, where it was egested normally, by the natural peristaltic motion (i.e. by human GI motility) of the GI tract. During its "tour", the colonic pressure data were recorded in the capsule firstly. The data were, then, transported to the pocket data logger via a radio-frequency (RF) transmitting module embedded in the capsule because of limited store memory on a chip. Finally, the data could be downloaded via universal RS-232 interface to our computer easily for further study.

During the experiment, the subjects did not complain of any discomfort except few volunteers had some difficulties to swallow at the beginning for their psychological factors and swallowed the capsules successfully with ease with another cup of water.

### C. Fractal and fractal dimension [9]–[13]

Generally, a fractal is an object that cannot be completely described by means of Euclidean geometry - it has too much structure. Fractal forms are composed of subunits (and sub-sub-units, etc.) that resemble the structure of the overall object. Unlike 1-D line, 2-D plane and 3-D cube, fractals have not a whole number description but a fraction falling between

integral dimensions, reminiscent of the coastline of the Great Britain. A number of complex anatomic structures also display fractal-like geometry. Examples include arterial and venous trees, the branching of certain cardiac muscle bundles, absorptive surface of small intestine, etc [6].

Since the box-counting dimension is so often used to calculate the dimensions of fractal sets because its estimation is conceptually simple. It is sometimes also referred to as fractal dimension.

We define the box-counting dimension (or just box dimension) of a set  $S$  contained in  $n$  as follows: For any  $\delta > 0$ , let  $N_\delta(S)$  be the minimum number of  $n$ -dimensional cubes of side-length  $\delta$  needed to cover  $S$ . If there is a number  $d$  so that

$$N_\delta(S) \sim 1/\delta^d \text{ as } \delta \rightarrow 0. \quad (1)$$

We say that the box-counting dimension of  $S$  is  $d$ . We will denote this by  $S = d$ .

Note that the box-counting dimension is  $d$  if and only if there is a positive constant  $c$  so that

$$\lim_{\delta \rightarrow 0} \frac{N_\delta(S)}{1/\delta^d} = c. \quad (2)$$

It will still hold if we take the logarithm of both sides since both sides of the equation above are positive and will obtain

$$\lim_{\delta \rightarrow 0} (\ln N_\delta(S) + d \ln \delta) = \ln c, \quad (3)$$

and,

$$d = \lim_{\delta \rightarrow 0} \frac{\ln c - \ln N_\delta(S)}{\ln \delta} = -\lim_{\delta \rightarrow 0} \frac{\ln N_\delta(S)}{\ln \delta}. \quad (4)$$

Note that the  $\ln c$  term drops out, because it is constant while the denominator becomes infinite as  $\delta \rightarrow 0$ . Also, since  $0 < \delta < 1$ ,  $\ln c$  is negative, so  $d$  is positive as we would expect.

Fig.4 illustrates the procedure to estimate the fractal dimension of a curve. First, select a box size  $\delta$  and count the number of boxes  $N_\delta(S)$  required to cover the curve. Then, change the box size and repeatedly count the number of boxes required to cover the curve. Finally, consider a log-log plot, that is a plot of the logarithm of  $N_\delta(S)$  versus the logarithm of  $\delta$ . The log-log plot should be linear and the negative slope of the line is the fractal dimension. For most fractal objects, this relationship holds true over a finite range of  $\delta$ . At small  $\delta$  this relationship is limited by the size of the particles that make up the object. At large  $\delta$  this relationship is limited by the size of the object.

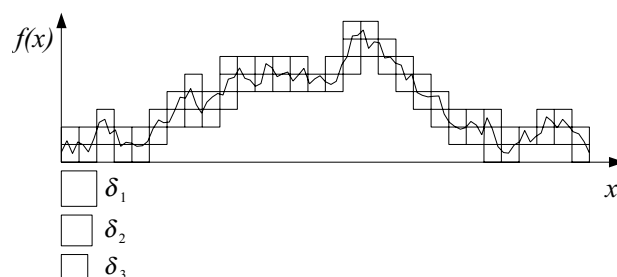

Fig.4. The estimation procedure of the fractal dimension

### III. RESULTS

#### A. The Colonic pressure activities

A representative colonic pressure activity wave (normal version) of a healthy 42-year-old female volunteer is shown in Fig.5(a). It mainly consists of seemingly irregular segmental waves with “erratic” fluctuations, which are referred to as phasic non-propagating contractions occurring either sporadically or in bursts for extracting the remaining nutrients and in particular water and electrolytes from the chyme in the colon.

Also, a clipped wave is generated. First, we try to find the baseline of the wave, which approximately represents the resting pressure, i.e., with few phasic contractions that cause the chyme to move, in the colon. Then, we clip all samples that exceed certain amplitude over the baseline. Thus, a clipped wave has essentially had some peaks chopped off. The clipped peaks are corresponding to colonic peristaltic contraction waves. The clipped version of the original pressure activity is shown in Fig.5(b). We use the clipped version to simulate the pressure data from the patients since colonic dysmotility often exhibits lower frequency contractions and/or lower phasic contractions with fewer high-amplitude spikes.

Moreover, we have recorded another colonic pressure activity (resting version) during the resting period of the colon at deep night of a healthy 33-year-old male subject, as seen in Fig.5(c). Obviously, during this period, the colon peristalsis is very slow. Accordingly, the recording pressure curve is rather flat with fewer spikes in Fig.5(c).

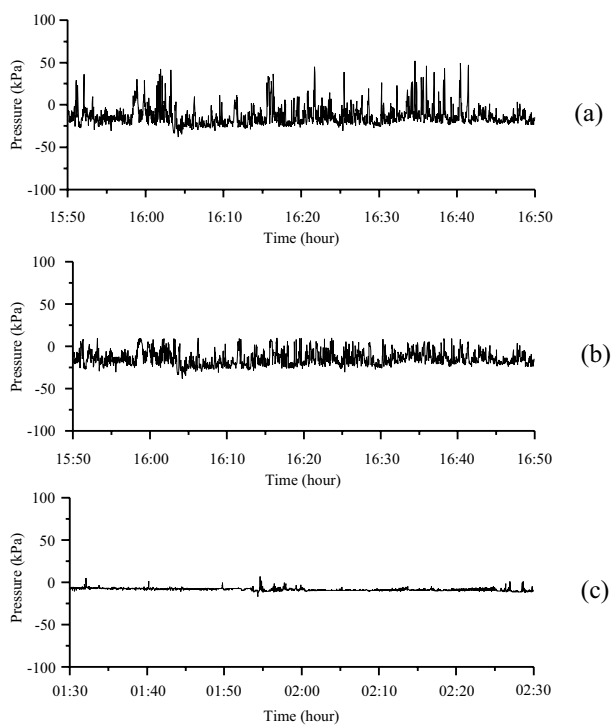

Fig.5. The colonic pressure activities with about one-hour  $2^{11}$  samples (a) Normal version consisting of seemingly irregular segmental waves with “erratic” fluctuations or spikes.

(b) Clipped version simulating the pressure activity of the patient with colonic dysmotility  
 (c) Resting version exhibiting fewer spikes in the recording pressure curve

#### B. Limitations of traditional techniques

Traditional time-frequency domain statistics include the averaged amplitude, the motility index, the power spectrum, etc., which are inappropriate for analysis in most cases:

##### (1) The averaged amplitude

Widely used traditional statistic is the averaged amplitude. However, The amplitude of the activity is quite variable from person to person and rarely can it give a satisfactory result.

##### (2) The motility index

Clinically, the motility index is calculated as the area under the curve (AUC) per unit time. However, it also has its disadvantage. One disadvantage of the AUC measure is that it does not reflect trends; that is, an activity with a period of improvement followed by deterioration might have the same AUC as one showed with deterioration followed by improvement [14]. This limitation may lead to erroneous measurement of the activity.

##### (3) The power spectrum

The power spectrum, which measures the relative frequency content of a signal, assumes that the signal studied is stationary, and when applied to nonstationary time series can lead to misleading results.

The colonic pressure activities the colonic tissue generates are considered to be nonlinear from the aspect that the colonic tissue is a complicated dynamic system and the colonic activities it generates are rhythmic wholly but irregular locally [4]. Generally, they are random, highly variable fluctuations without any obvious periodicity. Actually, such physiological signals are nonlinear, in many instances said to be fractal.

#### C. Fractal analysis

We, then, estimate the fractal dimensions of the normal version, the clipped version and the resting version using the box-counting method described in section 2. Fig.6 shows the plots of  $\ln N_\delta(S)$  versus  $\ln \delta$  for all versions in the same figure. The negative slope of each line is the fractal dimension. The

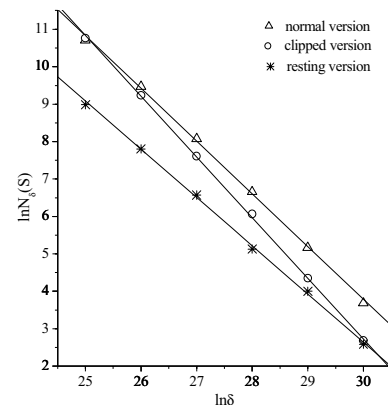

Fig.6. Plots of  $\ln N_\delta(S)$  versus  $\ln \delta$  for the normal, the shuffled, chipped and the resting pressure activities. The negative slope of each line is the fractal dimension.

fractal dimension of the normal version, the clipped version and the resting version are denoted  $d_n$ ,  $d_c$ ,  $d_r$ , where  $d_n = 1.51$ ,  $d_c = 1.73$ ,  $d_r = 1.29$ , respectively.

#### IV. DISCUSSION

We have estimated the fractal dimensions of the normal, the clipped and the resting version in section 3. The facts that the estimate dimensions of all versions are not integer numbers but fractional indicate that the human colonic pressure activities may exhibit fractal characteristics in a mathematical sense.

From a geometrical intuitive point of view, the fractal dimension is a "roughness" index of the original signal, that is, the larger the dimension is, the coarse the signal is, and vice versa. The representative colonic pressure activity in Fig.4(a) is smoother than the clipped version in Fig.4(b) since  $d_n < d_c$ ; and the activity during the resting period is the smoothest among all versions since the dimension is the smallest.

Furthermore, from the physiological point of the digestive system, the colon performs wave-like peristalsis with normal rhythm under the physiological conditions during the digestive period. The activities it generates are found to be fluctuations with "erratic" spikes, as shown in Fig.4(a). Nevertheless, during the resting or interdigestive period, the colon works lower near quiescence, and few spikes can be found (see Fig.4(c)). However, when someone complains of constipation, e.g. slow transit constipation, the colon may exhibit dysmotility with less rhythm and lower amplitude (see Fig.4(b)). Thus, the resting activity is the smoothest with the normal version followed; and the clipped one is the coarsest.

Moreover, fractal dimensions are nonlinear approaches to analyze the properties of complex systems, and lead to new insights into understanding physiological systems. Normal erratic fluctuations or spikes in the pressure activity probably means healthy. Significant complexity increasing of fractal dimension may indicate constipation.

#### V. CONCLUSIONS AND FUTURE WORK

In this paper, we studied the fractal characteristics of the normal pressure activity as well as the clipped and the resting version by using the box-counting method. The result shows that the normal activity is coarser than the resting version, and the clipped one, which corresponds to the activity from the constipation patient, is the coarsest. Unlike the traditional statistics, this method uses the fractal dimension to measure the curve from the global point of view.

However, more and more experiments on the subjects are needed to statistically verify fractal characteristics of human colonic pressure activities. Furthermore, Whether the activities of the patients really exhibit fractal properties and how they function needs to be involved in the future. Moreover, how to

elucidate the fractal and nonlinear mechanisms involved in physiological control also needs to be furthered.

#### REFERENCES

- [1] W.X Wang, G.Z. Yan, et al., "A non-invasive method for gastrointestinal parameter monitoring," *World Journal of Gastroenterology*, vol.11, no.4, pp.521-524, 2005.
- [2] P.P. Jiang, G.Z. Yang, et al., "Researches on a telemetry system for gastrointestinal motility monitoring," in *The International Symposium on Micromechatronics and Human Science*, 2003.
- [3] R.G Yan, G.Z Yan, W.Q Zhang, L. Wang, "Long-range correlations in human colonic pressure activity," in *The 5th International Workshop on Biosignal Interpretation*, Tokyo, Japan, 2005.
- [4] R.G. Yan, G.Z. Yan, L. Wang, "Nonlinear Chaotic Behaviours of Human Colonic Pressure Activity Based on Chaotic Theory," *WSEAS Transactions on biology and biomedicine*, vol.2, no.4, pp.343-350, 2005.
- [5] R.G. Yan, G.Z. Yan, L. Wang, "Nonlinear chaotic analysis of human colonic pressure activity," in *The 2005 WSEAS international conference on biophysics and bioengineering*, Athens, Greece, 2005.
- [6] A.L. Goldberger, L.A.N. Amaral, J.M. Hausdorff, P.C. Ivanov, C.K. Peng and H.E. Stanley, "Fractal dynamics in physiology: alterations with disease and aging," in *Proceedings of the National Academy of Sciences of the United States of America*, vol.99, suppl.1, pp.2466-2472, 2002.
- [7] [http://www.dchaos.com/portfolio/dchaos1/new\\_nonlinear\\_man\\_article.html](http://www.dchaos.com/portfolio/dchaos1/new_nonlinear_man_article.html).
- [8] <http://www.ortho.lsuhs.edu/Faculty/Marino/Temple/Temple.html>.
- [9] [http://www.math.sunysb.edu/~scott/Book331/Fractal\\_Dimension.html](http://www.math.sunysb.edu/~scott/Book331/Fractal_Dimension.html)
- [10] Rasband, S. N. "Fractal Dimension." Ch. 4 in *Chaotic Dynamics of Nonlinear Systems*. New York: Wiley, pp. 71-83, 1990.
- [11] B.B. Mandelbrot, *The Fractal Geometry of Nature*, San Francisco: Freeman, 1982.
- [12] A. Bunde, S. Havlin, *Fractals and Disordered Systems*, Springer Verlag, Berlin, Heidelberg, 1991.
- [13] <http://astronomy.swin.edu.au/~pbourke/fractals/fracdim/>
- [14] C. Liu, L.D. Blumhardt, "Disability outcome measures in therapeutic trials of relapsing-remitting multiple sclerosis: effects of heterogeneity of disease course in placebo cohorts," *J Neurol Neurosurg Psychiatry*, vol.68, no.4, pp.450-457, 2000.

**GUOZHENG YAN** obtained his PhD degree in mechanical engineering from Jilin University of Technology, Jilin, China, in 1993. Then, he worked as a postdoctoral researcher in Nanjing University of Aeronautics and Astronautics, Nanjing, China. Since March 1996, he has been a professor in Electronics and Electric Engineering at Shanghai Jiaotong University, Shanghai, China. He has been involved in teaching and research activities for the last nine years. Presently, he is working as a director of Instrument department. He has published over 80 research papers and guided a number of research scholars for their PhD theses. His research interests include Biomedical engineering, measurement and instrumentation, and signal processing.

**RONGGUO YAN** obtained his BE degree in mechanical engineering from Huaihai Institute of Technology, Lianyungang, China, in 1997, and ME degree in mechanical and electronic engineering from Nanjing University of Aeronautics & Astronautics, Nanjing, China, in 2001, respectively. He had worked in nanjing branch of ZTE Corporation from 2001 to 2003. Currently, he is pursuing his PhD in the school of electronics and electric engineering, Shanghai Jiaotong University, Shanghai, China. His interests mainly include biomedical instrument designing and biosignal processing.

**BANGHUA YANG** obtained her BE and ME degrees in mechanical and electronic engineering from Xi'an institute of Science and Technology, Xi'an, China, in 1993 and 1996, respectively. She had worked as a teacher from 1996 to 2003. Currently, she is pursuing her PhD in the School of Electronics and Electric Engineering, Shanghai Jiaotong University, Shanghai, China. Her interests include bio-signal processing and medical instrument designing.