

Characteristic of Discrete Raman Amplifier at Different Pump Configurations

Parekhan M. Jaff

Abstract—This paper describes the gain and noise performances of discrete Raman amplifier as a function of fiber lengths and the signal input powers for different pump configurations. Simulation has been done by using optisystem 7.0 software simulation at signal wavelength of 1550 nm and a pump wavelength of 1450nm. The results showed that the gain is higher in bidirectional pumping than in counter pumping, the gain changes with increasing the fiber length while the noise figure remain the same for short fiber lengths and the gain saturates differently for different pumping configuration at different fiber lengths and power levels of the signal.

Keywords—Optical Amplifier, Raman Amplifier Discrete Raman Amplifier (DRA), Wavelength Division Multiplexing (WDM).

I. INTRODUCTION

NONLINEAR effects within optical fiber provide optical amplification, This achieved by stimulated Raman scattering, stimulated Brillouin scattering or stimulated four photon mixing by injecting a high power laser beam into undoped or doped optical fiber. Raman amplification exhibits advantage of self phase matching between the pump and signal together with a broad gain- bandwidth or high speed response in comparison with the other nonlinear processes[1].there are two types of Raman amplifier discrete (lumped) and distributed Raman amplifier . distributed type Raman amplifier (DRA)utilizing transmission optical fiber as an active medium[2] if the amplifier is contained in a box at the transmitter or receiver end of the system it is called a discrete Raman amplifier.

This paper considers the gain and noise figure characteristic of discrete Raman amplifier as a function of fiber length at different pump configurations (bidirectional and counter pumping). Since the amount of noise transferred between the pump and the signal will depend on the pump configuration also in addition to the pumping configuration, the amount of noise transferred will depend on the gain and the length of fiber used. The variation of gain as a function of signal power at different pump configurations and fiber length were studied since the important parameters representing discrete Raman amplifiers is input power level of the signal[1].

II. DISCRETE RAMAN CONFIGURATION

Fig. 1 shows the basic configuration of discrete Raman amplifier. It generally comprises a gain fiber, a directional

Parekhan M. Aljaff is with the University of Sulaimani, Physics Department. She is now Dean of the College of Science, Iraq (e-mail: jparekhan@gmail.com).

coupler for combining the pump and the signal wavelength, and isolators at the input and output ends. The orientation of the pump can be either forward or backward with respect to the signal propagation, whereas the counter propagating one is called counter pumping; the copropagating pumping scheme is called copumping. There is also an option of bidirectional pumping, in which the gain fiber is pumped in both directions. [3]

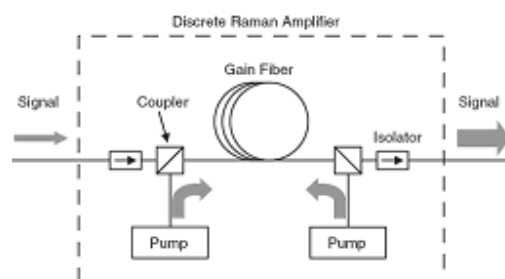

Fig. 1 Schematic of an optical communication system employing Raman amplification

III. THEORY OF RAMAN AMPLIFIER

A. Signal-pump Amplification

The evolution of the pump, P_p , and signal, P_s , powers along the longitudinal axis of the fiber z in a Raman amplified system can be expressed by the following equations [4]:

$$\frac{dP_s}{dz} = g_R P_p P_s - \alpha_s P_s \quad (1)$$

and

$$\mp \frac{dP_p}{dz} = -\frac{\omega_p}{\omega_s} g_R P_p P_s - \alpha_p P_p \quad (2)$$

Where $g_R(W^{-1}m^{-1})$ is the Raman gain coefficient of the fiber normalized with respect to the effective area of the fiber A_{eff} , α_s and α_p are the attenuation coefficient at the signal and pump wavelength respectively, ω_s and ω_p are the angular frequencies of the signal and pump, P_s and P_p are signal power and pump power. The \pm signs represent a co- and counter propagating pump wave, respectively. Equations (1) and (2) show that the signal receives gain proportional to the pump power with a proportionality constant given by the Raman gain efficiency and loss due to the attenuation of optical fiber, while the pump power receives loss due to the energy transfer to the signal and the attenuation of optical fiber. In many practical situations, pump power is so large compared with the signal power that pump depletion can be neglected by setting $g_R = 0$ in Eq. (2), As an example, $P_p(z) =$

$P_0 \exp^{-\alpha_p(L-z)}$, where P_0 is the input pump power at $z = 0$. If we substitute this solution in Eq. (1), we obtain:

$$\frac{dP_s}{dz} = g_R P_0 \exp(-\alpha_p z) p_s - \alpha_s P_s \quad (3)$$

This equation can be easily integrated to obtain [4]

$$P_s(L) = P_s(0) \exp(g_R P_0 L_{\text{eff}} - \alpha_s L) = G(L) P_{s(0)} \quad (4)$$

Where $G(L)$ is the net signal gain, L is the amplifier length, and L_{eff} is an effective length defined as

$$L_{\text{eff}} = [1 - \exp(-\alpha L)] / \alpha_p \quad (5)$$

The relation between the on-off Raman gain and the Raman gain efficiency is given as [4]:

$$G_A \equiv \frac{P_s(L) \text{ with pump on}}{P_s(L) \text{ with pump off}} = \exp(g_R P_0 L_{\text{eff}}) \quad (6)$$

Where $P_s(L)$ with pump on is assumed to be the amplified signal power without the amplified spontaneous emission (ASE) and thermal noise with pump on is assumed to be the amplified signal power without the amplified spontaneous emission (ASE) and thermal noise.

B. ASE Noise Figure (NF)

Equation (1) with the pertinent noise term [4].

$$\frac{dP_s}{dz} = -g_R P_p P_s - \alpha_s P_s + 2h\nu \Delta g_R P_p \quad (7)$$

The pump power P_p has a simple exponential form in the co pumping scheme as

$$P_p(z) = P_0 \exp(-\alpha z) \quad (8)$$

While in the counter pumping scheme,

$$P_p(z) = P_0 \{-\alpha_p(L-z)\} \quad (9)$$

The noise figure can be calculated based on Eqs. (7,8,9) through the following definition:

$$NF(\text{dB}) = 10 \log \left(\frac{S_{\text{in}}/N_{\text{in}}}{S_{\text{out}}/N_{\text{out}}} \right) \quad (10)$$

Where S and N denote the signal and noise parts in optical power at the given frequency, respectively.

The optical signal-to-noise ratio (SNR) of the amplified signal is given by:

$$SNR_o = \frac{P_s(L)}{P_{\text{ASE}}} = \frac{G_L P_{\text{in}}}{P_{\text{ASE}}} \quad (11)$$

$$P_{\text{ASE}} = 2 \int_{-\infty}^{\infty} S_{\text{ASE}} H_f(\nu) d\nu = 2 S_{\text{ASE}} B_{\text{opt}} \quad (12)$$

Where B_{opt} is the bandwidth of the optical filter. The factor of 2 in this equation accounts for the two polarization modes of the fiber, and ASE spectral density is defined as:

$$S_{\text{ASE}} = n_{\text{sp}} h \nu_0 g_R G_L \int_0^L \frac{P_p(z)}{G(z)} dz \quad (13)$$

IV. SIMULATION MODEL AND RESULTS

Average power model is used to decrease the computational time required to solve Raman amplifier differential equations (1 and 2). In this model, pump-to-pump, pump-to-signal, and signal to signal Raman interactions, Rayleigh back scattering, fiber loss, spontaneous Raman emission noise and its temperature dependency and pump depletion due to Raman energy transfer are included.

After entering the required parameters for a desired amplifier in main menu and sub menus of the program (optisystem7.) gain and noise figure can be obtained as a function of fiber length at different pump configurations, Fiber length swept from (0 to 100 km) for signal wavelength 1550nm, so the pump wavelength taken to be 1450 nm since the difference between pump and signal wavelength must be 100nm so as to obtain high Raman gain coefficient [5].

The default set of parameters for the simulations is listed in Table I, the simulation layout is shown in Fig. 2.

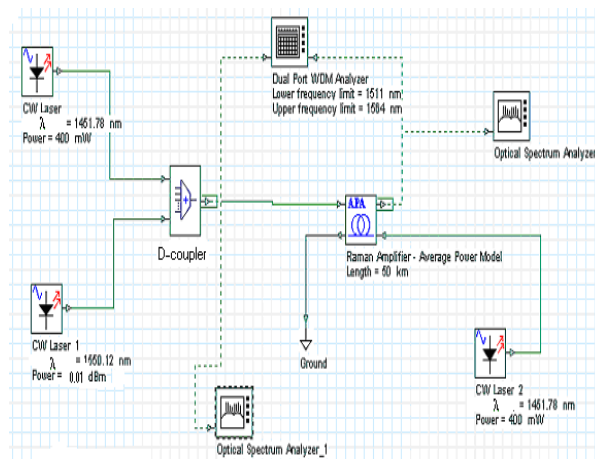

Fig. 2 The simulation layout, bidirectional pumping

TABLE I
LIST OF PARAMETERS USED IN THE SIMULATION

lName	Value	Units	Mode
Length	50	km	Sweep
Attenuation data type	Constant		Normal
Attenuation	0.2	dB/km	Normal
Attenuation file	FiberLoss.dat		Normal
Effective area data type	Constant		Normal
Effective interaction area	55	um ²	Normal
Effective interaction area fi	EffectiveArea.dat		Normal
Raman gain type	Raman gain		Normal
Raman gain peak	9.5e-014		Normal
Temperature	300	K	Normal
Polarization factor	2		Normal
Rayleigh back scattering d	Constant		Normal
Rayleigh back scattering	5e-005	1/km	Normal

As can be seen from Fig. 3 for a given pump power the amplifier gain increases up to a certain length of fiber, and then begins to decrease after a maximum point. The physical considerations for the decrease in gain is insufficient stimulated Raman scattering due to excessive pump depletion and getting higher losses than the provided gain at the signal wavelength, while the fiber attenuation plays a more important role for longer fiber length and the net gain decreases.

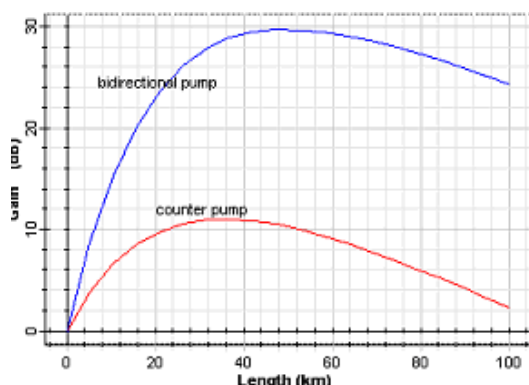

Fig. 3 Gain versus fiber length

Fig. 4 shows the noise figure as a function of the fiber length for counter pumping and bidirectional pumping, it is found that at short fiber length low noise figure is obtained with no significant difference between the counter and bidirectional pumping on the other hand for longer fiber length become remarkable because of the accumulation of noise along the fiber is different in the two cases.

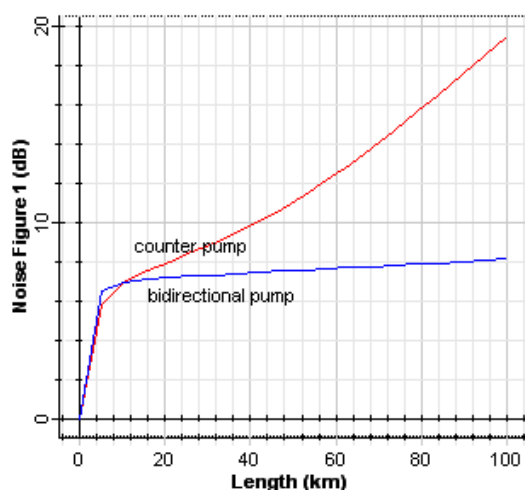

Fig. 4 Noise figure versus fiber length

To study the variation of gain as function of signal power in different pump configuration, the signal power is swept from (-20dBm to 20dBm) for two fixed fiber length (5km and 12km) since discrete Raman amplifiers have lengths around these wavelength. The other values of the simulation parameters are shown in Table I.

The gain saturates differently for different pumping configurations. Fig. 5 compares the different for the fiber lengths of 5km and 12km, saturation of gain increase as the

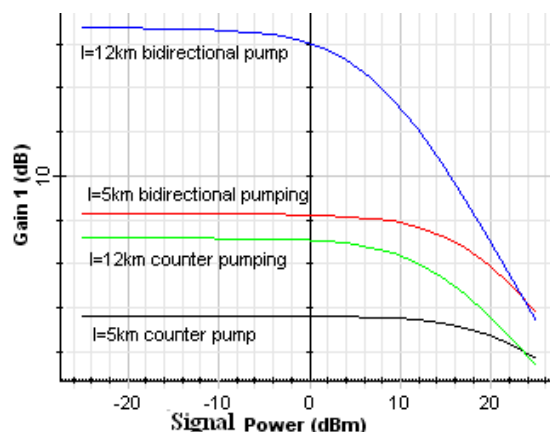

Fig. 5 Gain versus signal input power for different pumping configurations and fiber length

pump configuration changed also saturation increases as the fiber length increases because the more interaction or coupling due to the longer length, the more energy is transferred from the pump to the signal.

V. CONCLUSION

The net gain increase with increasing fiber length up to a certain length of fiber, and then begins to decrease after a maximum point and it's higher for bidirectional pumping than counter pumping. Noise figure remain the same value for both configurations at short fiber length. The gain Saturation increases as the pump configuration changed, it is higher for bidirectional pumping than counter pumping.

REFERENCES

- [1] John N. Senior "Optical Fiber Communications principles and practice" New Delhi, 2005.
- [2] H. S. Seo, Y. G. Ghio, and K. H. Kim "Design of transmission optical fiber with a high Raman gain, large effective area, low nonlinearity, and low double Raleigh back scattering "IEEE photonic technol.lett.vol.16,January 2004.
- [3] Clifford Headley, Govind P. Agrawal, a book on "Raman amplification in Fiber Optical Communication Systems" United States of America, 2005.
- [4] G. P. Agrawal, Nonlinear Fiber Optics (Academic Press, San Diego, 1995), Chap. 8.
- [5] Mohammed N. Islam "Raman Amplifiers for Telecommunications", IEEE journal of selected topics in quantum electronics, vol. 8, no. 3, June 2002.
- [6] S. A. E. Lewis, S. V. Chernikov, and J. R. Taylor, Electron. Lett. 35, 923(1999).
- [7] R. P. Espindola, K. L. Bacher, K. Kojima, N. Chand, S. Srinivasan, G. C.Cho, F. Jin, C. Fuchs. Milner and W. C. Dautremont-Smith, in 27th European Conference on Optical Communication, Proceedings (Amsterdam, The Netherlands, 2001), paper PD.F.1.7.

Parekhan M. Aljaff was born in Kirkuk, Iraq, on July 1954. She received Bachelor Degree in physics from Sulaimany University. Sulaimany, Iraq, 1976, and the MSc., and PhD. degrees in University of Babes- Bolyai Culi-Napoca, Romania, 1984.

She became Assistant professor in 2004. She is now Dean of the College of Science. She has many researches, one of them published in Trieste, Italy, on lasers in Chemistry, 1991, also researches published in journals in Iraq, Sulaimani, Journal of Zancoy Sulaimani, Part A, Vol.6 (1)2003 and in Iraq, Duhok, Journal of Duhok University, v1.2, no. 1, 1999. Also research published in journal of World Academy of Science, Engineering and Technology, volume 36, Dec.2008, Bangkok, Thailand.