

Firing Angle Range Control For Minimising Harmonics in TCR Employed in SVC's

D. R. Patil and U. Gudaru

Abstract—Most electrical distribution systems are incurring large losses as the loads are wide spread, inadequate reactive power compensation facilities and their improper control. A typical static VAR compensator consists of capacitor bank in binary sequential steps operated in conjunction with a thyristor controlled reactor of the smallest step size. This SVC facilitates stepless control of reactive power closely matching with load requirements so as to maintain power factor nearer to unity. This type of SVC's requiring a appropriately controlled TCR. This paper deals with an air cored reactor suitable for distribution transformer of 3phase, 50Hz, Dy11, 11KV/433V, 125 KVA capacity. Air cored reactors are designed, built, tested and operated in conjunction with capacitor bank in five binary sequential steps. It is established how the delta connected TCR minimizes the harmonic components and the operating range for various electrical quantities as a function of firing angle is investigated. In particular firing angle v/s line & phase currents, D.C. components, THD's, active and reactive powers, odd and even triplen harmonics, dominant characteristic harmonics are all investigated and range of firing angle is fixed for satisfactory operation. The harmonic spectra for phase and line quantities at specified firing angles are given. In case the TCR is operated within the bound specified in this paper established through simulation studies are yielding the best possible operating condition particularly free from all dominant harmonics.

Keywords—Binary Sequential switched capacitor bank, TCR, Nontriplen harmonics, step less Q control, Active and Reactive power, Simulink

I. INTRODUCTION

A typical shunt compensator to be employed in a distribution system primarily consists of capacitor units, series and shunt reactors for inrush current limiting purpose and to provide variable inductive reactive power respectively, thyristors for control purpose and switchgear for protection. Reactors are employed in power systems for various purposes both in series and shunt forms in LT and HT systems. There exists number of types designed and manufactured to serve variety of applications. In this paper air cored reactor is introduced, design considerations are dealt and the operating principle of thyristor controlled reactor and its use in static VAR compensator is considered along with power quality

D.R.Patil Department of Electrical engineering, Walchand College of Engineering, Sangli, Maharashtra, INDIA, PIN-416415dadasorpatil@gmail.com

U. Gudaru Member, IEEE, Department of Electrical Engineering, Walchand College of Engineering, Sangli, Maharashtra, INDIA, PIN-416415 ugudaru@gmail.com

issues such as harmonics, active and reactive power, d. c. components and specifically triplen harmonic magnitudes by using the MAT LAB SIMULINK. Most commonly the capacitors are invariably provided with reactors in series on line side or neutral side. Small value chokes in LT, 6% reactors on line or 0.2% reactors on neutral side in HT applications, 13% reactors at 25 KV traction substations and specially designed tuned reactors in filter circuits, are in use. They can be of air cored, air/oil cooled, dry type or of gaped core type, with or without shielding. In majority cases the role of a reactor is somewhat limited; the cost is relatively high and is also associated with high percentage losses. In the specific application of static VAR compensator in LT distribution systems, the thyristor controlled reactor is arranged across a shunt capacitor (FC-TCR) to obtain continuously variable reactive power.

A. Air Cored Reactor Design

Air cored coils are preferred as the inductance remains constant over the entire range of operation. This is most suitable for static VAR applications. Its design is given bellow [1] making use of formula given for a multi layer reactor,

$$L = \frac{0.8a^2n^2}{6a + 9b + 10c} \quad \text{Micro-Henry's (1)}$$

Where n = no. of turns; a = mean radius of the coil; b = length of the coil; c = thickness of the winding. All dimensions are in inches. Each air cored coil is rated for 220 volts, 2 Amps and single phase with approximately 700mH Inductance. This is suitable for thyristor controlled reactor to be connected in delta form with coils on either side of two thyristors in anti parallel mode in each phase. 17 SWG super enameled wire is used for the reactor. The dimensions obtained as per the above mentioned formula are as follows: a = 4.5 inches; b = 6 inches; c = 2.5 inches; n = 1500 turns, number of layers = 14, turns per layer = 107/108; ID = 6.5 inches; OD = 11.5 inches; MD = 9 inches; Weight of copper 15.25 kg per coil; Dimensions of super enameled wire employed are 17 SWG, 1.589 mm², 1.42 mm diameter, 14.13 Kg. weight per Km length. Total length of wire used is approximately 1.07 km / coil. There are thirteen gaps between layers each approximately 4 mm thick, separated by strips for insulation purpose. Total number of six such coils are built and tested in the laboratory for their inductance values. The schematic diagram of air cored reactor is shown in Fig.1. It has been found that they all have the inductance, resistance and impedance values in close proximity as shown in Table 1.

B Thyristor Controlled Reactor (TCR)

A typical TCR scheme with two thyristors connected in anti-parallel mode in each phase for phase control is shown in Fig 2. It is possible to vary the reactive power level from zero to the KVAR rating of the coil by controlling the delay angle through appropriate triggering. The TCR circuit and the associated wave forms for both voltage and current are shown in Fig. 2(a) & (b) [2]-[3]. As shown in Fig. 2(b) the current

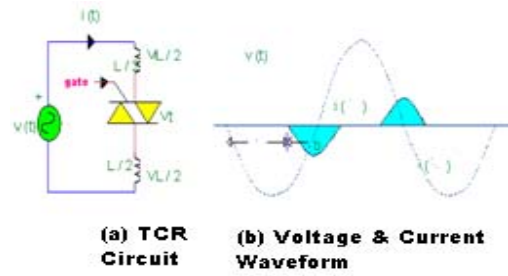

Fig.2 (a) TCR Circuit and (b) Voltage and Current Wave Forms

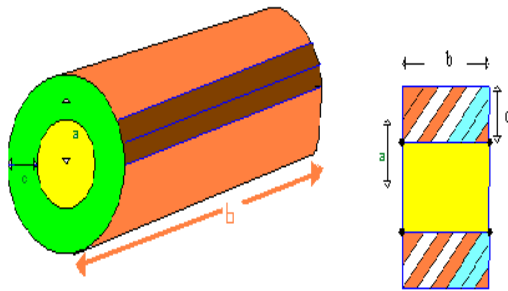

Fig. 1 Schematic Diagram of Air Cored Coil

Fig. 1 Schematic diagram of air cored reactor

TABLE I
 TEST RESULTS OF THE SIX REACTOR COILS DESIGNED

Coil No.	1	2	3	4	5	6
Impedance Z ₁ to Z ₆ Ohms.	98.25	102.8	104	105	100	105
Resistance R ₁ to R ₆ Ohms.	10.6	11.23	10.7	10.9	10.9	11.5
Inductance L ₁ to L ₆ mH.	310	325	329	332	316	332

in a TCR can be continuously varied from zero (corresponding to $\sigma = 0$) to maximum (corresponding to conduction angle of 180°) by phase control in which the firing σ (with respect to zero crossing of voltage is varied from 180° to 90°). The instantaneous current i_{TCR} over a half cycle is given by

$$i_{TCR} = \frac{\sqrt{2}V}{X_L} (\cos \alpha - \cos(\omega t)) \quad \alpha < \omega t < (\alpha + \sigma)$$

$$= 0 \quad (\alpha + \sigma) < \omega t < (\alpha + \pi) \dots \dots \dots (2)$$

Where V is RMS voltage applied, X_L is the reactance at fundamental frequency. The conduction angle σ is related to α by

$$\sigma = 2(\pi - \alpha) \dots \dots \dots (3)$$

The amplitude $I_L(\alpha)$ of the fundamental reactor current $i_{TCR}(\alpha)$ can be expressed as a function of an angle α : [5]

$$I_L(\alpha) = \frac{V}{X_L} \left(1 - \frac{2}{\pi} \alpha - \frac{1}{\pi} \sin 2\alpha \right) \dots \dots \dots (4)$$

TCR can control the fundamental current from zero (valve closed) to a maximum (valve opened) amounting to continuously variable reactive admittance. Thus the admittance varies with α in the same manner as the fundamental current $I_L(\alpha)$. When TCR is in operating condition in conjunction with a switched capacitor bank, it is necessary to adjust B_L continuously to get the requisites KVAR. The reactor must be linear in the entire range and unsusceptible to differ in inductance value with voltage / current spikes. Hence air cored reactors are preferred for static VAR compensator proposed in this work. The error adaptive SVC controller will take care of switching of binary weighted capacitors $C_0, C_1=2C_0, C_2=2C_1, C_3=2C_2, C_4=2C_3$. The values of capacitors selected are: $C_0=2.5, C_1=5, C_2=10, C_3=20$ and $C_4=40$ KVAR respectively. The capacitors switching signals and thyristor gate pulses gives raise a continuous stepless variable reactor of the range of -2.5 to 77.5 KVAR. The entire error adaptive binary sequentially switched capacitor bank with TCR of 2.5 KVAR is as shown in Fig. 3. This entire scheme has been implemented at the Walchand College of Engineering, Sangli, India.

II. SYSTEM DATA FOR CASE STUDY

A typical single line distribution feeder originating from a sub-station to Walchand College of Engineering Sangli campus load centers is shown in Fig. 4. A three-phase 11KV/433V, Dy11 transformer is employed in the Institute for catering to the loads locally. Walchand College of Engineering, Sangli is getting supply from MSEDL through 11 KV feeder and their ratings are as follows:
 11 KV feeder of length 5 km. H.T. Supply: 11 KV over head feeder: Mink 7/3.66 mm ACSR conductor; Resistance per Km. distance: 0.49 Ω ,

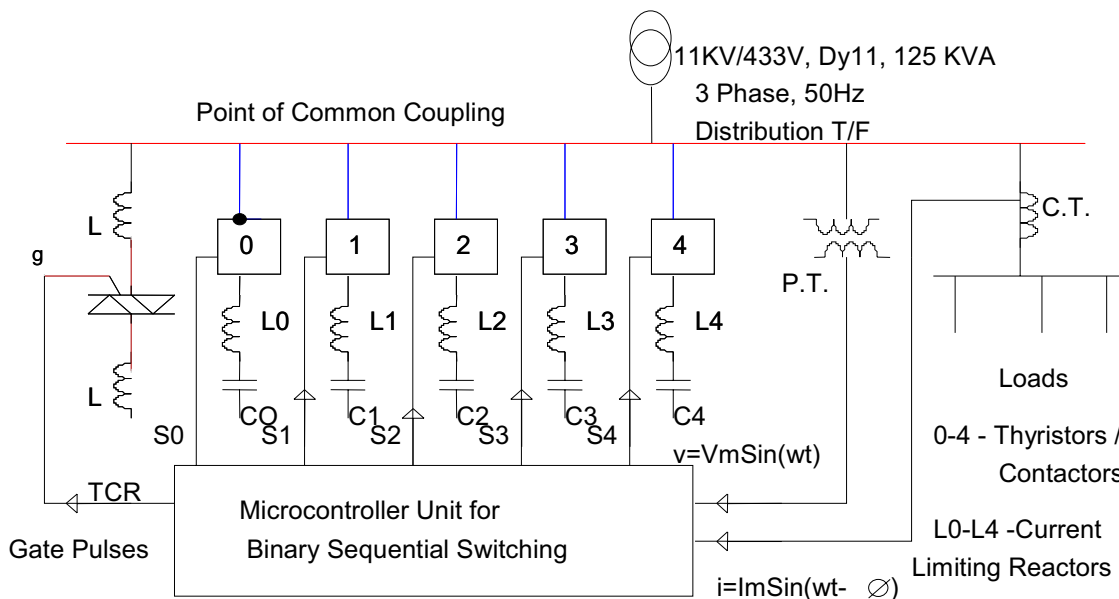

Fig. 1 Basic FC-TCR Scheme

Reactance per Km. distance: 0.365Ω ; Transformer rating: 125KVA, 11KV/433V, 50 Hz. Dy11; Percentage impedance: 4.25 ohms; Capacitor bank rating: 77.5 KVAR; No. of steps: 5 Steps in KVAR: 2.5, 5, 10, 20, 40 KVAR. All the system parameters are calculated and referred to low voltage side. These are as listed below:

1. Source Reactance = $X_s = 0.3175 \Omega$
(With 20KA short circuit level)
2. Transformers impedance referred to primary $Z_p = 41.1 \Omega$
Copper losses in the transformer as 2000 Watts,
Equivalent resistance $R_p = 15.49 \Omega$
And reactance $X_p = 38.069 \Omega$.
3. Feeder parameters: Distance = 5 Km; $R_f/Km = 0.49\Omega$; $X_f/Km = 0.365\Omega$. And $R_f = 0.49 \times 5 = 2.45 \Omega$ & $X_f = 0.365 \times 5 = 1.825 \Omega$
Equivalent values referring to H. V. side
Total resistance $R_{HV} = 17.94 \Omega$
Total equivalent reactance $X_{HV} = 40.259 \Omega$

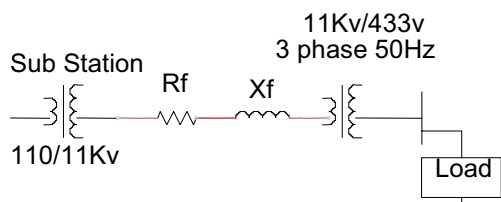

Fig.4 Single Line Diagram of Distribution System

The equivalent values referring to L. V. sides are

$$R_{LV} = 0.0287 \Omega$$

$$X_{LV} = 0.06431 \Omega; (X_{LV} = 0.2047mH)$$

All the parameters are shown in the equivalent diagram Fig. 5.

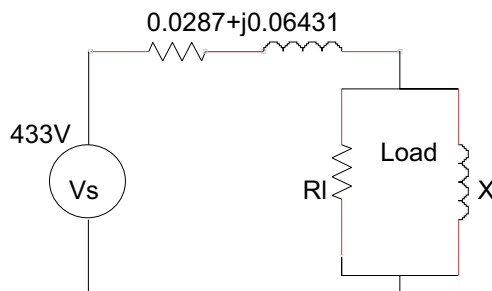

Fig.5 Parametric Diagram on L.V. Side

A. FC-TCR Scheme

The Fig. 6 shows the basic configuration of static compensator FC-TCR. In this case capacitor represents a switched capacitor bank either as mechanically switched or thyristor switched in binary sequential steps as explained earlier and L represents reactor with phase angle control [5]-[7].

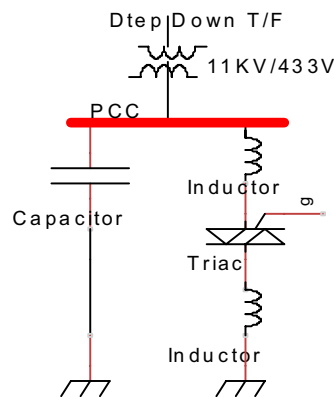

Fig. 6 FC-TCR Scheme

The controllable range of TCR firing angle α extends from 90° to 180° . In case of ideal reactor of L Henry firing angle of 90° results in full conduction with continuous sinusoidal current flow. Practically all six air cored reactors are designed with an average resistance of 10Ω and inductance of 230 mH. The following “(5)” [5] illustrates the relation between firing angle α and the current through inductor I_L for ideal inductor having resistance tending towards zero while “(6)” represents the practical case considering resistance $R \Omega$.

$$I_L = \left(\frac{V}{\omega L} \right) \left(1 - \left(\frac{2}{\pi} \right) \alpha - \left(\frac{1}{\pi} \right) \sin 2\alpha \right) \dots\dots\dots (5)$$

$$I_L(\alpha) = \frac{V_m}{\sqrt{R^2 + X_L^2}} \left[\frac{1}{2\pi} \left\{ (\beta - \alpha) + \frac{\sin 2\alpha}{2} - \frac{\sin 2\beta}{2} \right\} \right]^{0.5} \dots\dots(6)$$

The following observations are important

- i) If $\alpha = \theta$ i. e. firing angle = phase angle
 $\sin(\beta - \theta) = \sin(\beta - \alpha) = 0$
 and conduction angle = $\beta - \alpha = \pi$
- ii) Conduction angle should not exceed π

The range of control angle α is $\theta \leq \alpha \leq \pi$

$$I_{1\alpha} = \frac{V_L}{Z} = V_m Y_{TCR}(\alpha - \theta) \dots\dots\dots (7)$$

Where

$$Y_{TCR(\alpha-\theta)} = Y_{Max} \left[\frac{1}{2\pi} \left\{ (\beta - \alpha) + \frac{\sin 2\alpha}{2} - \frac{\sin 2\beta}{2} \right\} \right]^{0.5} \dots\dots\dots (8)$$

Thus the TCR acts like a variable admittance. By varying the firing angle α admittance changes and consequently fundamental current component which in turn gives rise to variation of reactive power absorbed by reactor. Hence if $\alpha = \theta = 85.5^\circ$ continuous conduction of current take place. However, if firing angle is increased beyond this, non-sinusoidal currents are generated and hence harmonics get introduced. The rms value of nth order harmonic is expressed as a function of α in the following equation:

$$I_1(\alpha) = \frac{V}{Z} \times \frac{2}{\pi} \left[\frac{-2 \cos(\alpha - \theta) \sin n(\alpha - \theta) + \sin(n-1)(\alpha - \theta) + \sin(n+1)(\alpha - \theta)}{n-1} + \frac{\sin(n+1)(\alpha - \theta)}{n+1} \right]$$

Where, $n = 2k+1$ and $k = 1, 2, 3 \dots \dots\dots (9)$

III. SIMULINK MODEL

A three phase delta connected TCR with SSR is shown in the Fig. 7. With six different coils as follows:

- $L_1 = 310\text{mH}; L_2 = 325 \text{ mH}; L_3 = 329 \text{ mH};$
- $R_1 = 10.6; R_2 = 11.23; R_3 = 10.7;$
- $L_4 = 332 \text{ mH}; L_5 = 316 \text{ mH}; L_6 = 332 \text{ mH};$
- $R_4 = 10.9; R_5 = 10.87; R_6 = 11.5;$

The reactor coil in the phase is split in two halves as shown in the Fig. 7 to prevent the full AC voltage appearing across the SSR. The entire Simulink model has been shown in the Fig.8. The display of all the line and phase currents

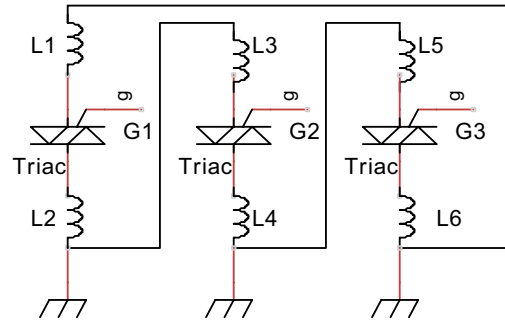

G1 , G2 , G3 --- Gate Pulses
 L1 -----L6 Reactors

Fig. 7 Delta connected TCR

waveforms are carried out for firing angles $\alpha = 90^\circ, 99^\circ, 108^\circ, 117^\circ, 126^\circ, 135^\circ, 144^\circ,$ and 153° . Since all the inductors do not have exactly the same magnitudes, it results in slight asymmetrical operation. The Table 2 shows the various fundamental rms magnitudes as well as percentage of harmonic current generated with respect to fundamental component of the current for firing angle α varying from 85° to 175° . The data for various firing angles α was collected. The various parameters noted are fundamental current component to the 12th harmonic component, active and reactive power values. The plot of magnitude of the entire harmonics v/s firing angle is depicted in Fig.9 to 15.

IV. SIMULINK MODEL RESULTS

The Fig. 9 shows the fundamental line and phase current magnitude variation with respect to the firing angle α . Due to this current, KVAR compensation can be controlled. From the Table II and Fig. 13(a) to 13(d) it is observed that because of asymmetrical operation all triplen harmonics are not cancelled but their magnitudes are reduced considerably. These are insignificant in normal circumstances. This asymmetrical operation results in generating a DC component which has been listed in the Table II also and shown in the Fig. 10. In addition to the harmonics, small in phase component of current (approximately 0.5 to 2%) of fundamental frequency flows in TCR which represents copper losses in TCR winding. The quality factor for TCR coil Q_F equals to

$$\frac{\omega L}{R} = \eta_2$$

is accounting for these losses which are listed in Table 2. The plot of active and reactive power variation with respect to firing angle α is also considered in fig. 12. While, Fig. 11 shows the percent THD component variation with respect to firing angle α . As the angle α approaches to 180° , the THD goes on increasing. It is observed that the safest region of TCR operation without significant harmonics is in between 90° to 130° . The fig. 14 shows all the line and phase odd harmonics. These odd harmonics have a significant magnitude beyond the firing angle α is equal to 130° . Fig. 15 shows all the even harmonics having a small magnitude up to α is equal to 130° . While beyond this angle even harmonics

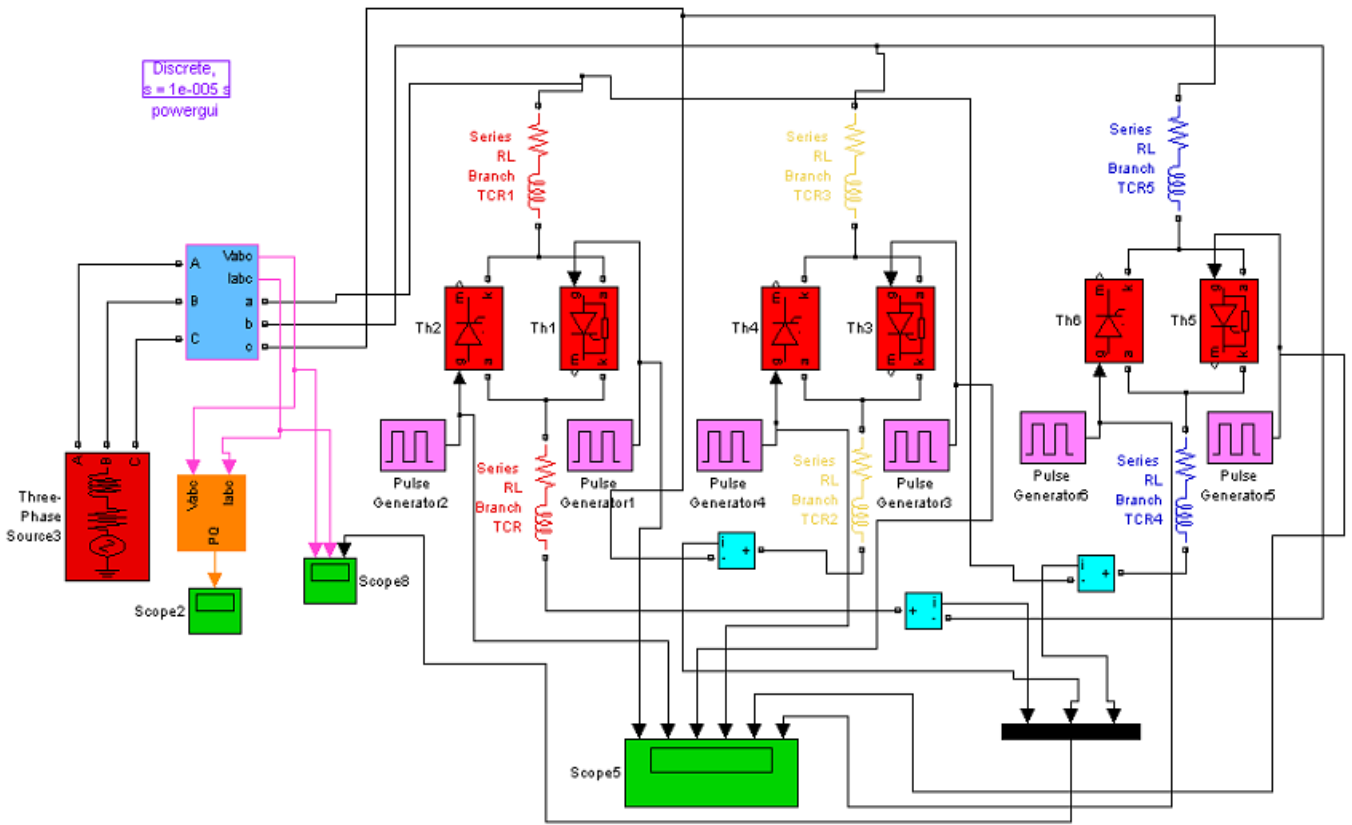

TCR SIMULATION MODEL

Fig. 8 TCR simulation model

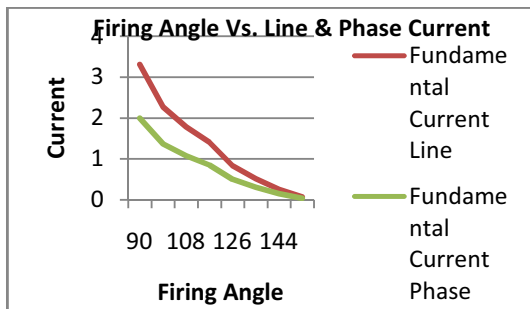

Fig.9 Fundamental component of line & phase current for TCR

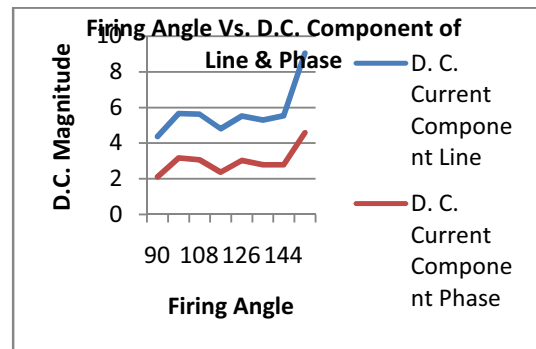

Fig.10 D. C. components of TCR

Table II Simulated Results of TCR for various firing angle (α)

Sr. No	Firing Angle (α)	Fundamental Current		D. C. Current Component		THD		H2%		H3%	
		Line	Phase	Line	Phase	Line	Phase	Line	Phase	Line	Phase
1	90	3.307	1.994	4.36	2.11	6.76	7	5.37	4.84	2.48	3.64
2	99	2.267	1.366	5.65	3.17	12.13	20.81	5.79	4.93	2.7	16.65
3	108	1.781	1.078	5.62	3.06	15.12	31.41	6.04	4.95	2.84	27.47
4	117	1.405	0.848	4.79	2.37	14.03	39.48	6.07	4.84	3.01	36.79
5	126	0.8323	0.501	5.51	3.02	17.35	58.87	6.71	5.47	3.45	55.94
6	135	0.5113	0.309	5.29	2.78	32.13	79.38	6.9	5.36	4.07	73.19
7	144	0.2537	0.153	5.52	2.79	58.22	133.44	7.51	5.68	4.37	96.42
8	153	0.06617	0.040	9.03	4.57	180.09	243.56	11.76	9.26	7.54	168.67

H4%		H5%		H6%		H7%		H8%		H9%	
Line	Phase	Line	Phase	Line	Phase	Line	Phase	Line	Phase	Line	Phase
2.01	2.03	0.75	1.15	1	1.08	1.11	1.29	0.8	0.94	0.73	0.64
2.22	2.86	7.93	8.51	0.55	0.85	5.21	5.49	0.9	1.23	0.68	3.19
2.15	3.36	11.81	12.14	0.65	0.88	5.9	6.13	1.03	1.35	0.68	1.97
1.75	3.67	10.85	11.08	1.43	1.52	4.03	4.46	1.02	1.18	0.69	2.62
1.05	4.27	4.11	2.03	2.47	2.87	14.46	14.22	0.69	0.62	0.74	7.59
0.12	4.91	22.2	20.38	3.1	4.18	21.01	19.85	0.36	1.08	0.93	5.86
1.37	5.86	54.87	52.58	5.16	5.98	15.43	12.8	0.65	3.67	1.75	21.99
5.89	9.79	148.5	141.43	14.86	11.59	94.79	92.57	6.97	11.97	2.7	30.4

H10%		H11%		H12%		H13%		Active Power	Reactive Power
Line	Phase	Line	Phase	Line	Phase	Line	Phase	in KW	in KVAr
0.62	0.64	0.84	0.8	0.59	0.61	0.5	0.43	1.9	4.1
0.61	0.59	2.42	2.12	0.64	0.72	1.43	1.25	1.2	2.8
0.72	0.72	1.09	1.21	0.59	0.74	0.37	0.62	1	2.25
0.79	1.05	2.83	3.24	0.43	0.67	0.69	0.59	0.8	1.75
0.64	1.46	1	1.52	0.42	0.86	2.4	2.44	0.5	1
0.54	1.49	4.47	3.84	0.79	1.23	1	1.54	0.3	0.6
0.95	1.06	0.1	0.85	1.05	1.45	4.28	3.97	0.15	0.3
4.39	3.67	25.36	26.58	1.18	2.3	11.55	11.55	0.025	0.075

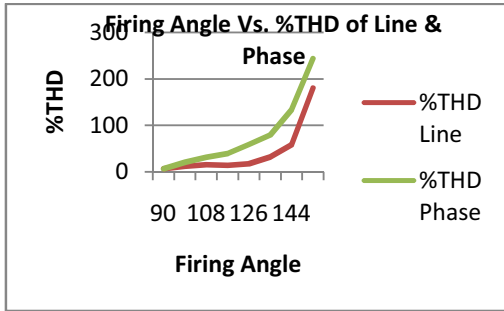

Fig.11 Total THD components of TCR

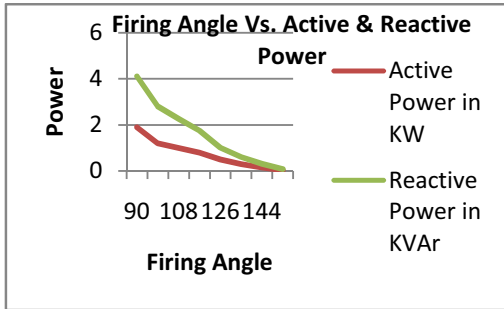

Fig.12 Active & Reactive power of TCR

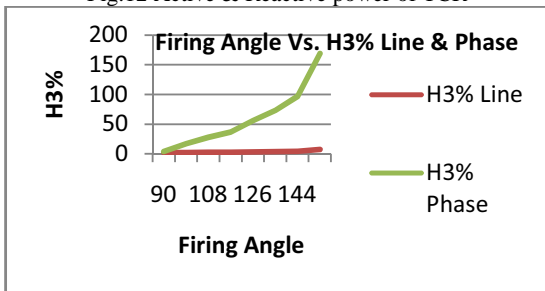

Fig.13(a) Triplen harmonics of TCR for H3

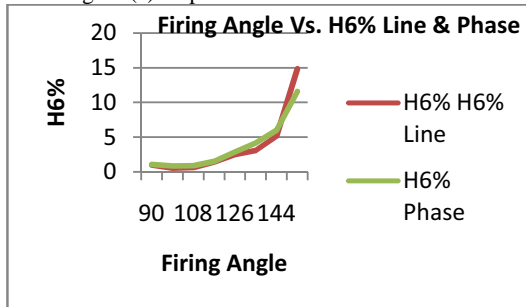

Fig.13(b) Triplen harmonics of TCR for H6

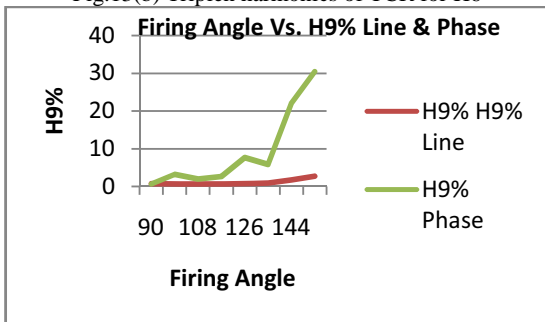

Fig.13(c) Triplen harmonics of TCR for H9

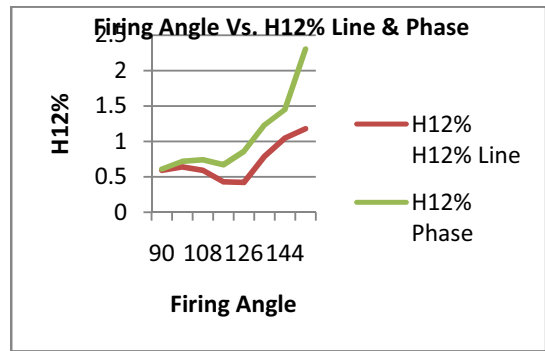

Fig.13(d) Triplen harmonics of TCR for H12

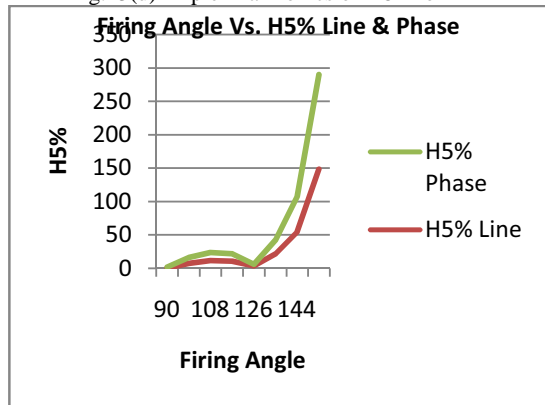

Fig.14(a) Odd harmonics of TCR for H5

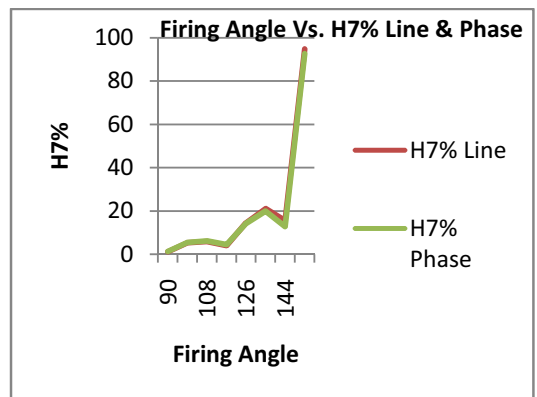

Fig.14(b) Odd harmonics of TCR for H7

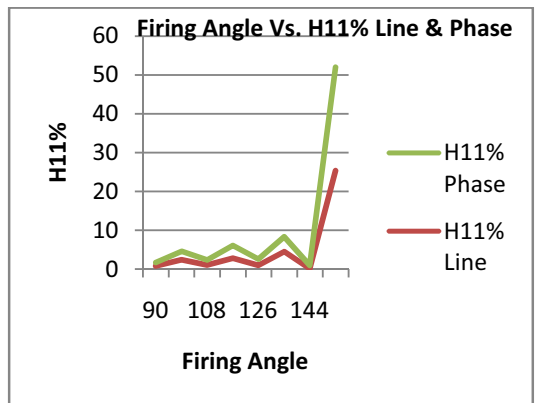

Fig.14(c) Odd harmonics of TCR for H11

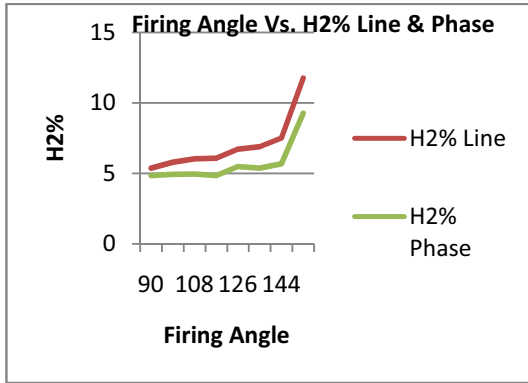

Fig.15(a) Even harmonics of TCR for H2

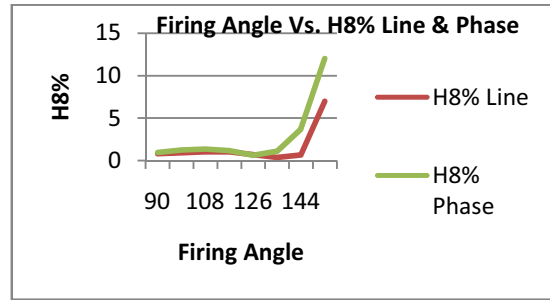

Fig.15(c) Even harmonics of TCR for H8

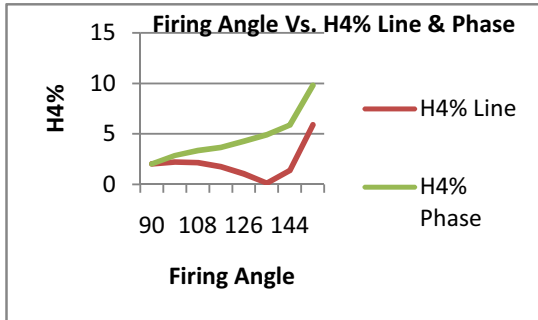

Fig.15(b) Even harmonics of TCR for H4

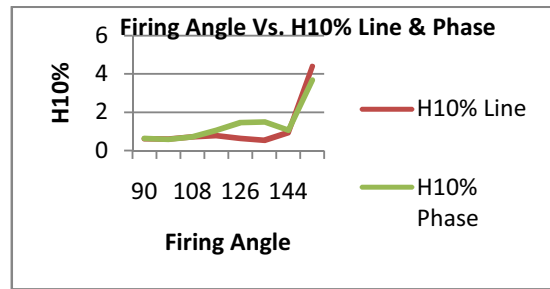

Fig.15(d) Even harmonics of TCR for H10

goes on increasing abruptly. Whenever firing angle is 85° the conduction is smooth and all the quantities are sinusoidally varying. There are no harmonics detected. But as the firing angle goes on increasing from 85° to 175° , more and more harmonics are get generated. For various firing angles, as listed earlier, different wave forms are recorded. The waveforms are: 3 phase line & phase currents, total active and

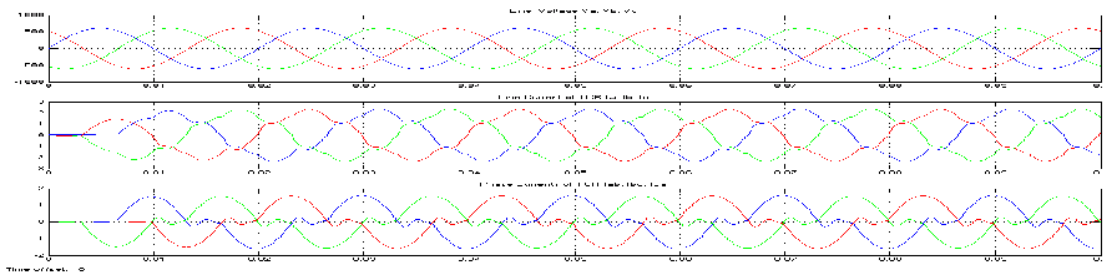

Fig. 16 Line and phase current for $\alpha = 117^{\circ}$

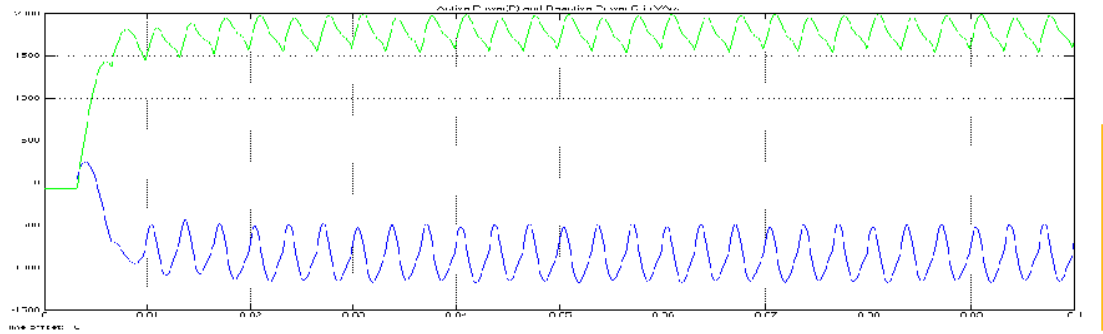

Fig. 17 Active and reactive power for $\alpha = 117^\circ$

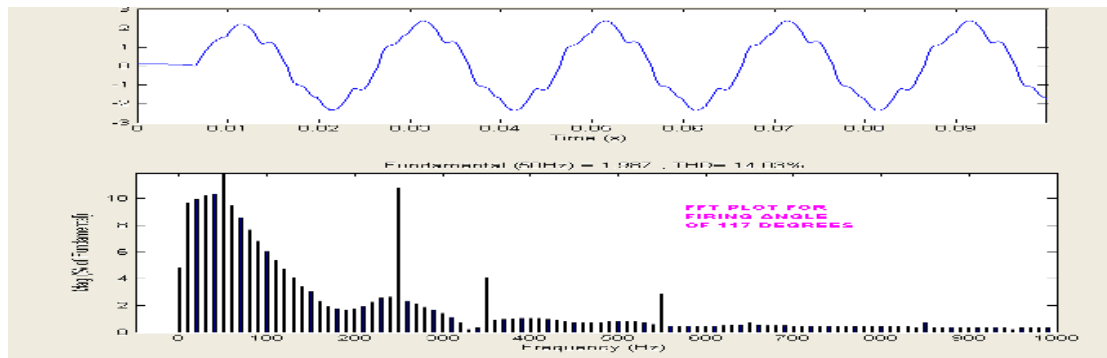

Fig. 6.37 Harmonic spectrum of line current for $\alpha = 117^\circ$

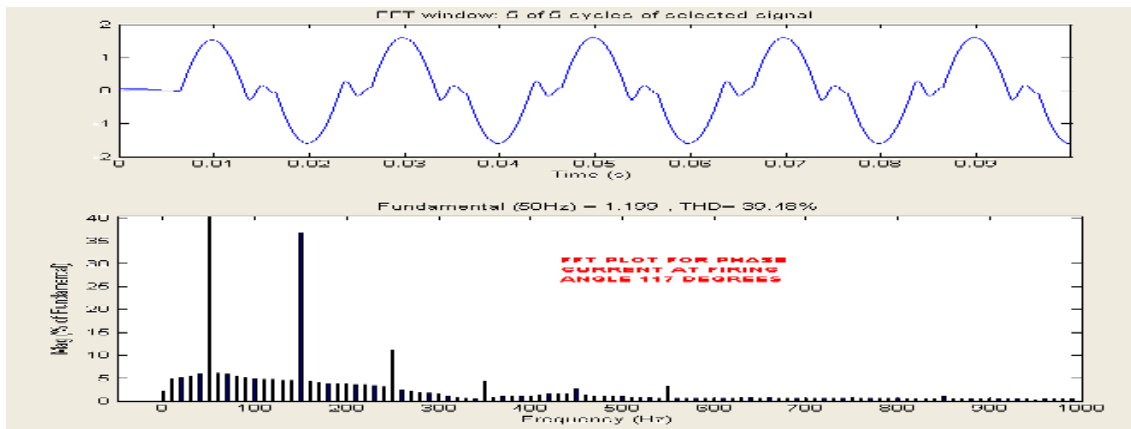

Fig. 18 Harmonic spectrum for phase current at $\alpha = 117^\circ$

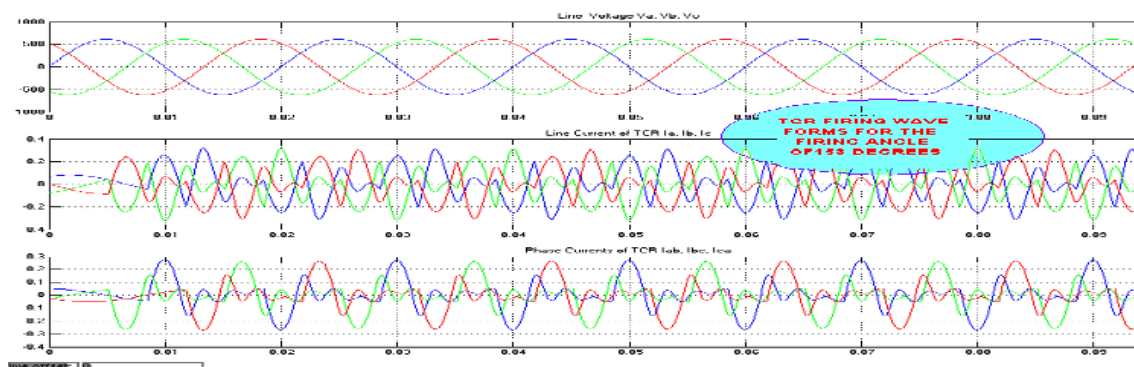

Fig. 19 Line and phase current at $\alpha = 153^\circ$

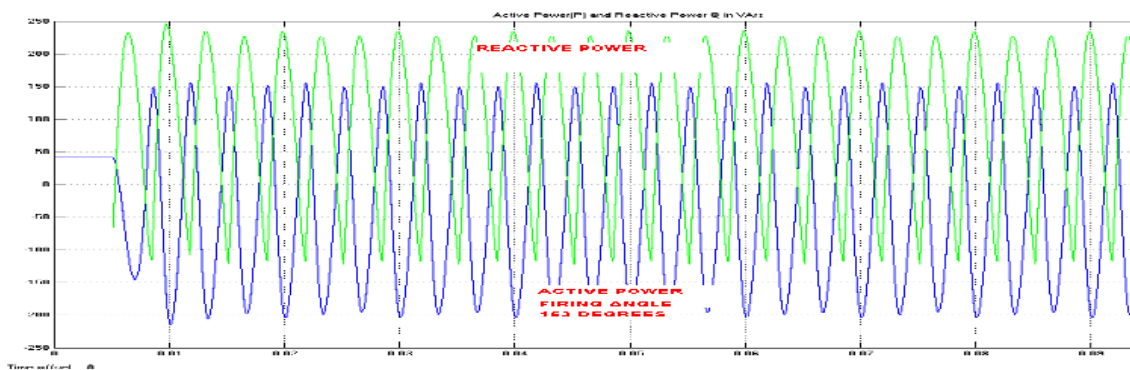

Fig.20 Active reactive power at $\alpha = 153^{\circ}$

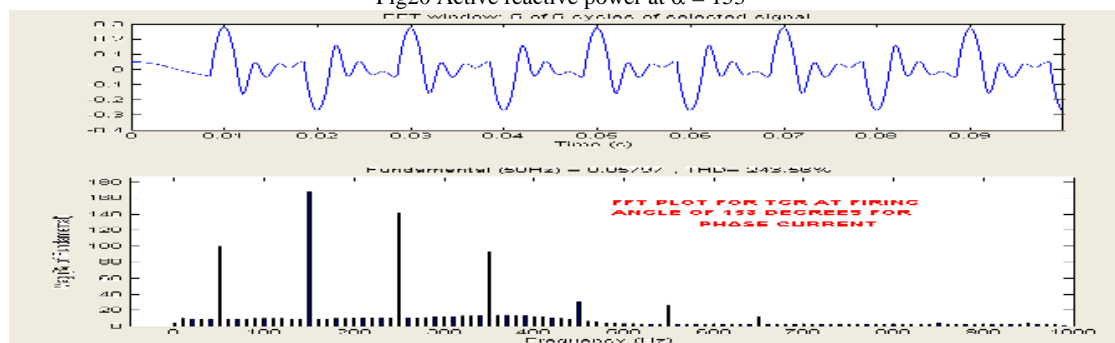

Fig. 21 Harmonic Spectrum for phase currents at $\alpha = 133^{\circ}$

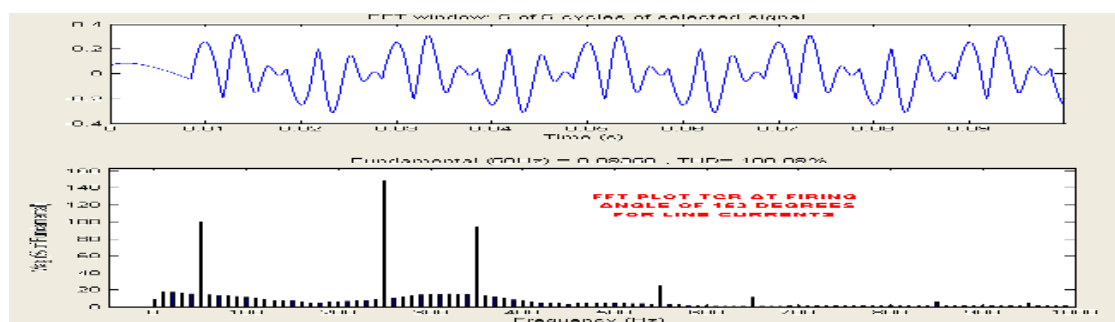

Fig.22 Harmonic spectrum for line current at $\alpha = 153^{\circ}$

V.CONCLUSION

Air cored reactor suitable for delta connected TCR to be operated in conjunction with a capacitor bank in five binary sequential steps are designed, tested and simulation studies are carried out. TCR is the heart of atypical static VAR compensator and problem of harmonics is very sever. A comprehensive work is carried out through simulation studies with the sole purpose of fixing angle range so as to minimize triplen, characteristic and even harmonics on the line side. Thoroughly investigation ravel the firing angle range between 85 to 130 degrees which gives very satisfactory performance with regard to harmonics, real and reactive powers, D.C. components and other variables. A scheme dealt in this paper is practically implemented on live system and the results are matching with simulation study values..

REFERENCES

- [1] Herold Pender and Knov McIwain, "Electrical Engineers Hand Book".
- [2] U. Gudar, Satish Sangale and D. R. Patil, "Adaptive static VAR compensation for Rural Distribution Systems" presented at the workshop on 'Reactive Power Compensation in Power Systems', organized by Engineering Staff College of India, Hyderabad, June 1992.
- [3] A. Hammad and B. Roesle, "New roles for static Var compensators in transmission system", Brown Boveri Rev., Vol. 73, pp 314-320, Jun. 1986.
- [4] J. Kearly et. al., "Microprocessor controlled reactive power compensator for loss reduction in Rural Distribution Feeders", IEEE Transactions on power delivery, Vol. 6, No. 4. October 1991, pp. 1848-1855.
- [5] Narain G. Hingorani and L. Gyugyi, "Understanding FACTS" IEEE Press.
- [6] K. Stahlloepf, M. Wichelm, "Tighter Controls for Busier System", IEEE Spectrum, April 1977, P 49-52.
- [7] J. Grahm, "Transient stability enhancement using Static Var Compensation", Wart Verginia University, Thesis, 378, 3543 Engg. G76tc2, Oct. 1995.
- [8] U. Gudar, "Microprocessor based static compensator of TSC and TCR type meeting A. C. System control requirements", published in CAPACIT-86 by IEEMA M. Young, *The Technical Writers Handbook*. Mill Valley, CA: University Science, 1989.