

Understanding the Discharge Activities in Transformer Oil under AC and DC Voltage Adopting UHF Technique

R. Sarathi, and G. Koperundeivi

Abstract—Design of Converter transformer insulation is a major challenge. The insulation of these transformers is stressed by both AC and DC voltages. Particle contamination is one of the major problems in insulation structures, as they generate partial discharges leading it to major failure of insulation. Similarly corona discharges occur in transformer insulation. This partial discharge due to particle movement / corona formation in insulation structure under different voltage wave shapes, are different. In the present study, UHF technique is adopted to understand the discharge activity and could be realized that the characteristics of UHF signal generated under low and high fields are different. In the case of corona generated signal, the frequency content of the UHF sensor output lies in the range 0.3-1.2 GHz and is not much varied except for its increase in magnitude of discharge with the increase in applied voltage. It is realized that the current signal injected due to partial discharges/corona is about 4ns duration measured for first one half cycle. Wavelet technique is adopted in the present study. It allows one to identify the frequency content present in the signal at different instant of time. The STD-MRA analysis helps one to identify the frequency band in which the energy content of the UHF signal is maximum.

Keywords—Contamination, Insulation, Partial Discharges, Transformer oil, UHF sensors.

I. INTRODUCTION

IN the large scale interconnected power system network, HVDC power transmission play a major role and converter transformers forms important part in it. The reliability of transformers insulation relies on ageing condition caused due to operating electrical stress, thermal stress caused due to overloading, mechanical stress due to electrical vibration caused by the core of the transformer and in addition any contaminant (conducting/non conducting) present in the liquid insulation can cause overstress to the insulating medium initiating localised partial discharges. The manufacturers diagnose the quality of the insulation of the converter transformer by carrying out certain routine tests before installation, which includes AC voltage withstand test, DC voltage test with simultaneous partial discharge measurement, polarity reversal test with partial discharge (PD) measurement etc [1,2].

The authors are with the Department of Electrical Engineering Department, Indian Institute of Technology Madras, Chennai, India (phone: +91-44-2257 4436; fax: +91-44-2257 4402; e-mail:rsarathi@iitm.ac.in).

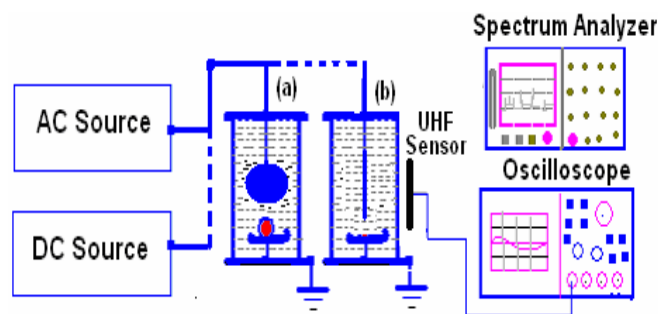

Fig. 1 Experimental Setup (a) Test cell for particle movement study (b) corona discharge study

In this entire test, the partial discharge test provides information regarding incipient discharges that occur in the insulation medium, caused due to defects present in the insulation. The micro defect may be formed due to small protrusion from the winding, which can cause corona and if floating conducting/non-conducting particles present in the transformer oil enhancing the local electric field initiating partial discharges.

Tobazeon observed that when the charged conductive particle comes close to opposite electrode, charge transfer occurs and produces a current peak shorter than 1ns duration [3]. When Partial discharge current pulses involves rise and fall times of a nanosecond or less, signals in the Ultra High Frequency (UHF) range (300-3000MHz) are excited [4,5]. The UHF technique for partial discharge identification in transformers is gaining acceptance due to its high sensitivity and good signal to noise ratio [4]. Considerable research activity has been carried out on partial discharge activity in transformer oil insulation, e.g., [6,7]. Measurements have indicated that the UHF signals radiated by partial discharges propagate at the speed of light in oil ($\sim 2 \times 10^8$ m-s⁻¹) and are attenuated by about 6db per 10 m of travel [8].

The UHF PD detection technique is basically a Non-Destructive Testing (NDT) tool to identify any active defects present in the insulation structure during operation. Having known all this, in the present work, an attempt has been made to correlate the characteristics of UHF signal generated due to particle movement forming partial discharges and corona formation in the transformer oil insulation, under AC and DC voltages. In addition, the multi resolution signal decomposition-wavelet techniques were adopted to

understand the frequency contents of the UHF signal generated due to corona and partial discharges.

II. EXPERIMENTAL

The experimental setup used for the measurement of UHF signal generated due to partial discharges/corona activity in the transformer oil, under the AC and DC voltages is shown in Fig. 1. The experimental setup for the present study could be sectioned in to three parts. The first, second and third part of the experimental setup includes the high voltage source, the oil test cell (Test Apparatus) and the UHF sensor connected to spectrum analyzer/oscilloscope respectively.

(i) High Voltage Source

The high AC voltage of power frequency is produced from a transformer rated for 5KVA, 50 Hz, 100 kV unit. The AC voltage is measured using the capacitance voltage divider. The DC voltage is generated through a Greinacher voltage doubler circuit and it is measured using the resistance method.

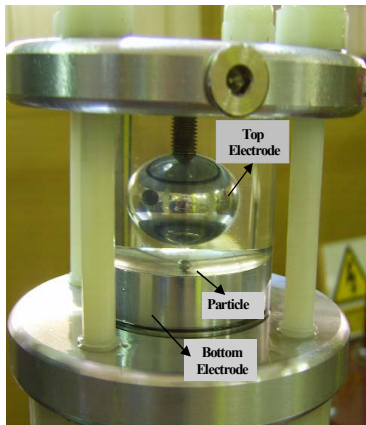

Fig. 2 Photograph of the test cell for particle movement study

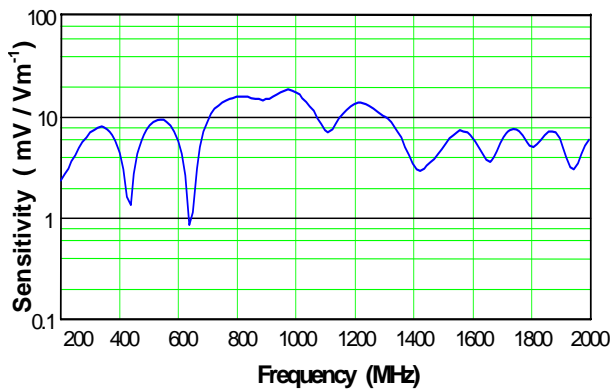

Fig. 3 Frequency response of the UHF sensor

(ii) Test Cell Details

In the present study two different electrode configurations were used Viz. 1. Sphere plane configuration with conducting particle in the gap for partial discharge study and 2. Needle plane configuration for corona discharge study. The test cell used in the present work is shown in Fig. 2. In the sphere-plane configuration, the two electrodes were placed in a

cylindrical container filled with transformer oil. The upper electrode is a spherical electrode of diameter 1.5cm and the lower one was a slightly concave shape dish electrode to contain the particle. The gap between two electrodes maintained at 10 mm. A small aluminium ball of diameter 2.5 mm was placed in the concave lower electrode while the high voltage was connected to the top electrode.

With Needle-plane electrode configuration, the top electrode is a needle electrode with radius of curvature of about 50um (replacing the sphere with needle electrode) and the bottom is a plane electrode. The gap between the needle and the plane electrode maintained at about 10mm. The corona/partial discharge current shape and magnitude was measured using oscilloscope by measuring the potential drop across the resistance which is connected in series with the bottom electrode. In the present study, the AC and the DC voltages were increased at a rate of 300 V/s up to the required test voltage level.

(iii) UHF Sensor Details

The UHF sensors used for partial discharge detection must have broadband response, the reason being the frequency content of signals from a PD varies depending on its location and the signal path. Sensors used for GIS monitoring have also proved suitable for oil filled transformer monitoring. GIS sensitivity requirements stipulate both an average and a minimum sensitivity over the range of 0.5 to 1.5GHz [9, 10]. The sensor used in the present study is a broadband type sensor, which is placed at a distance of 20cm away from the test cell. Fig. 3 shows the sensor frequency response as measured using a UHF calibration system [9]. The output of the UHF sensor connected to the spectrum analyzer/high bandwidth digital storage oscilloscope. The UHF signals were captured using a real time digital storage oscilloscope (LeCroy four channel digital real time oscilloscope, 3 GHz bandwidth, operated at 20 GSa/s) with an input impedance of 50 ohms. A spectrum analyzer (Hewlett Packard E4402B ESA-E-Series) was also used to measure signal frequency in the range 0-3 GHz with resolution bandwidth of 3 MHz. The spectrum analyzer was used in full span mode and in zero span modes.

III. INTRODUCTION TO WAVELET TRANSFORM

Wavelet analysis involves the breaking up of a signal into shifted and scaled versions of a single prototype function called the original or mother wavelet [11]. A mathematical definition of continuous wavelet analysis is as follows:

Let $x(t)$ be a signal defined in $L^2(\mathbb{R})$ space, which denotes a vector space for finite energy signals. \mathbb{R} is a real continuous number system. The signal must satisfy the condition that;

$$\int_{-\infty}^{\infty} x^2(t) dt < \infty \quad (1)$$

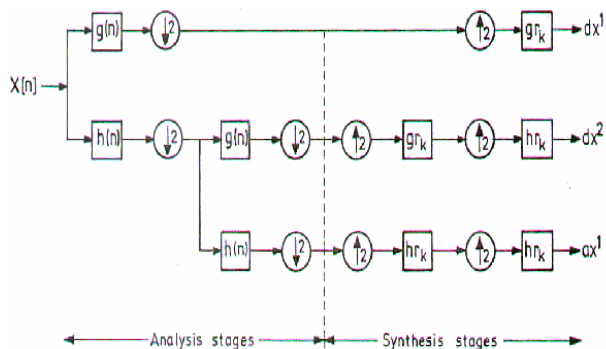

Fig. 4 Schematic representation of implementation of MRSD

The CWT of $x(t)$ is then defined as:

$$CWT_x^\psi(\tau, s) = \psi_x^\psi(\tau, s) = \frac{1}{\sqrt{|s|}} \int x(t) \psi^* \left(\frac{t-\tau}{s} \right) dt \quad (2)$$

where $\psi(t)$ is called a basic wavelet (or mother wavelet). The asterisk denotes a complex conjugate, and $\tau, s \in \mathbb{R}$, $s \neq 0$ are the translation and dilation or scale parameters respectively. The functions that are used as mother wavelets have net area equal to zero. The time analysis is performed with a contracted i.e. low scale, high frequency version of the mother wavelet, while frequency analysis is performed with a dilated i.e. high scale, low frequency version of the same wavelet.

The Discrete Wavelet Transform (DWT) is given by

$$DWT_x^\psi(m, n) = \frac{1}{\sqrt{a^m}} \int x(t) \psi^* \left(\frac{t-nba^m}{a^m} \right) dt \quad (3)$$

This method maps continuous variable into a sequence of coefficients. In the above equation $x(t)$ is discretized signal function and $\psi(t)$ is the wavelet function.

Let $c_0(n)$ be a discrete time signal recorded using certain measuring device. The signal has to be decomposed into a detailed and smoothed representation. From the Multi Resolution Signal Decomposition (MRSD) technique, the decomposed signals at scale 1 are $c_1(n)$ and $d_1(n)$, where $c_1(n)$ is the low pass version of the original signal and $d_1(n)$ is the high pass representation of the original signal $c_0(n)$ in the form of wavelet transform coefficients. They are defined as,

$$c_1(n) = \sum_k h(k-2n)c_0(k) \quad (4)$$

$$d_1(n) = \sum_k g(k-2n)c_0(k) \quad (5)$$

where $h(n)$ and $g(n)$ are the associated filter coefficients that decompose $c_0(n)$ into $c_1(n)$ and $d_1(n)$ respectively. The next higher level decomposition is based on $c_1(n)$. The decomposition signal at scale 2 is given by

$$c_2(n) = \sum_k h(k-2n)c_1(k) \quad (6)$$

$$d_2(n) = \sum_k g(k-2n)c_1(k) \quad (7)$$

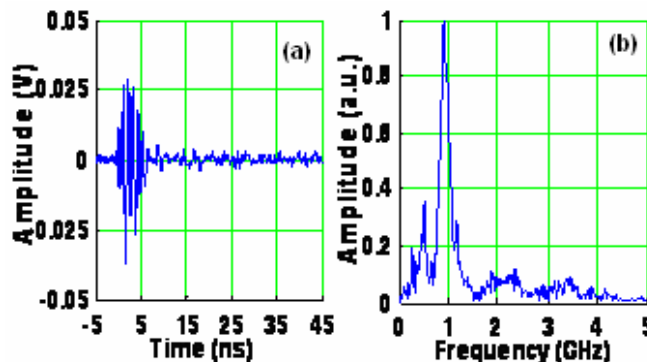

Fig. 5 Typical UHF signal measured due to particle movement in transformer oil (a) time domain signal (b) normalized FFT of (a)

Higher scale decompositions are performed in the same way as described above [12]. The implementation of the multi-resolution signal decomposition technique is explained by Fig. 4. In the present work Daubechies 4 wavelet has been chosen for the analysis for CWT and DWT. The standard deviation can be considered as a measure of the energy present in the signal with zero mean [13]. The purpose of carrying out the standard deviation is to identify the transient energy present at any point of time. Therefore, the Standard Deviation Multi-Resolution Analysis (STD_MRA) is used in the present work as feature to identify occurrence of PD event.

IV. RESULTS AND DISCUSSION

In the present study, UHF technique was adopted to understand two important aspects that occur in transformer insulation Viz. (i) Partial discharge formation due to particle movement in transformer oil and (ii) Corona discharge activity in transformer oil.

(i). Partial Discharge Study Due to Particle Movement

Particle contamination is one of the major problems in transformer insulation. Krinz et al., observed that conducting particle affects the breakdown strength of the oil than the insulating particle [14]. Birlasekaran has studied particle movement in transformer oil under AC and DC fields both theoretically and by experimental study [15,16]. He concluded that under DC voltages, conductive particles transport charge by contact with electrodes and observed the discharge current in the form of a fast rising current pulse and slowly increasing displacement current [15]. The equation of motion of a particle in transformer oil under an applied electric field can be written as [17]

$$ma = Fe + Fd \pm Fg \quad (8)$$

Where m is the mass of the particle, a is the particle acceleration, Fe is the electrostatic force, Fg is gravitational force and Fd is the viscous drag force. The drag force is a function of particle shape, size and the viscosity of the liquid. It is observed that the levitation voltage under AC voltage is 5 kV and for DC voltages it is 7 kV. These levitation voltages were established based on the first pulse being captured by the

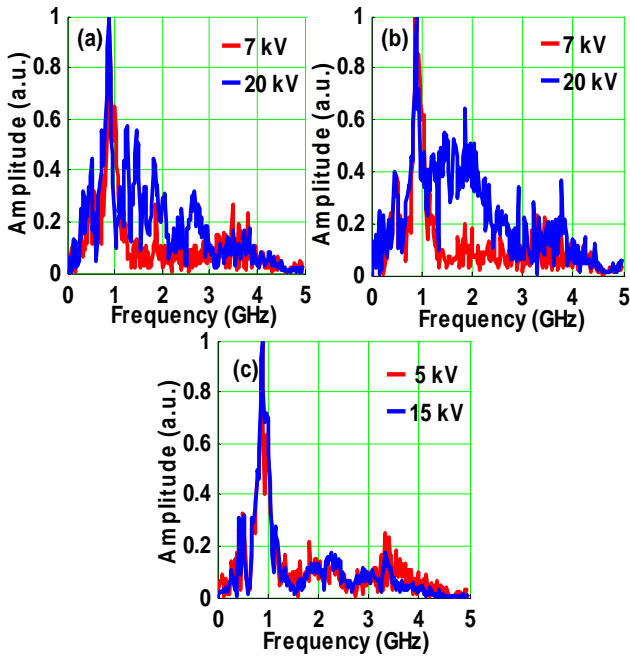

Fig. 6 Frequency domain analysis of UHF signal measured due to particle movement in transformer oil under different voltages (a) +DC (b) -DC and (c) AC voltage

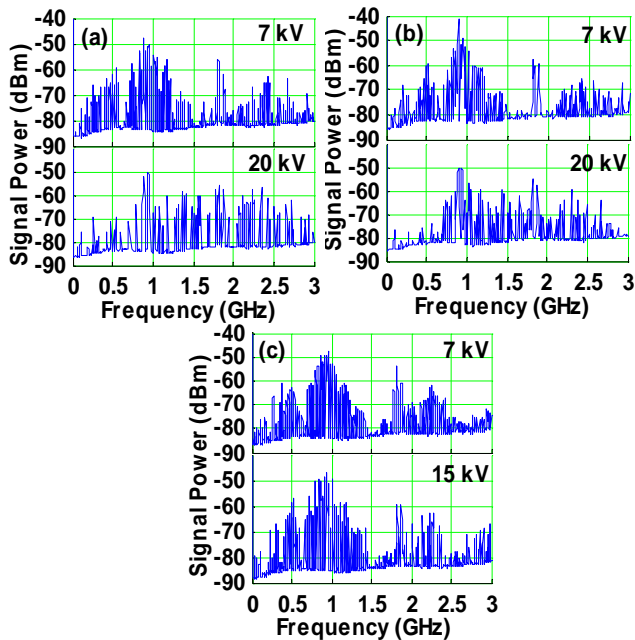

Fig. 7 Typical spectrum analyzer display of UHF signals due to particle movement in transformer oil under different voltages using spectrum analyzer (a) +DC (b) -DC (c) AC

oscilloscope through the UHF sensor output. It is also realized that under DC voltages, the levitation voltage is almost the same and is independent of polarity of the applied voltage. Fig. 5 shows the typical UHF signal generated due to particle movement in transformer oil and the corresponding FFT plot. It is observed that the dominant frequency of the UHF signal is about 1 GHz.

A. Time and Frequency Domain Analysis of UHF Signal Generated Due to Partial Discharges

The partial discharge is basically a charge transfer process, which occurs in about an ns range, excites UHF signal. Fig.6 shows characteristic variation in frequency content of UHF signal generated by the partial discharge formed due to particle movement in transformer oil at different voltage magnitudes, under AC and DC voltage. It is observed that, under DC voltages, at just above the levitation voltage, the frequency content of UHF signal generated lies in the range 0.5-1.2 GHz and further increase in voltage shows dominant frequencies in the range 1-3 GHz. The characteristic variation is high with negative DC voltage. Under DC voltages, when a particle is levitated, its motion is based on the charge it acquired and the applied electric field in its immediate vicinity.

Under the DC voltage, the particles acquires the charge and levitates once the electric force exerted on the particle exceeds the combined gravitational and drag forces. It then moves to the opposite electrode and as it approaches the surface, charge transfer takes place through a microdischarge between the electrode and the particle. Once the particle comes in contact with the opposite electrode (top electrode), it acquires its charge and moves in towards the ground electrode. In the process, the gravitational forces aid the particle movement enhancing its velocity [15]. This cycle continues causing localized partial discharges near to the electrode surfaces. Under AC voltage, the UHF signal generated is almost the same at the voltage above levitation and at higher fields. The cause for it is due to time varying fields under AC voltage.

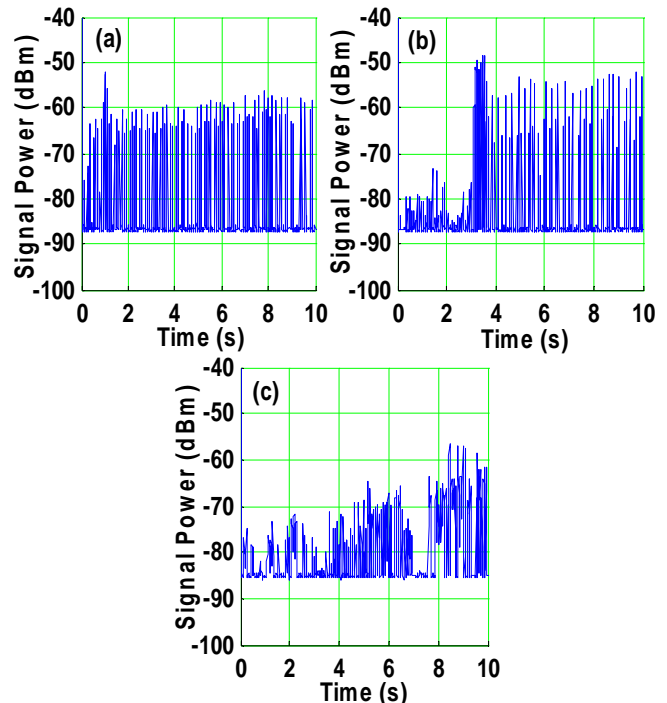

Fig. 8 Zero span analysis of UHF signal generated by partial discharged due to particle movement under different voltages (a) +DC (b)-DC and (c)AC

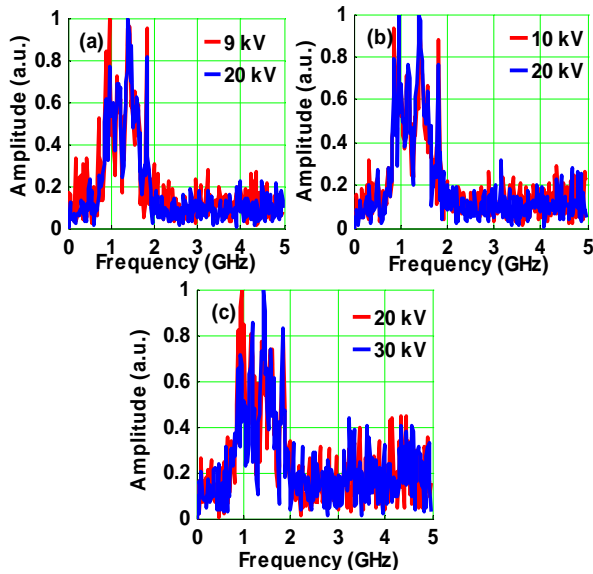

Fig. 9 Frequency domain analysis of UHF signal measured due to corona in transformer oil under different voltages (a) +DC (b) -DC and (c) AC voltage

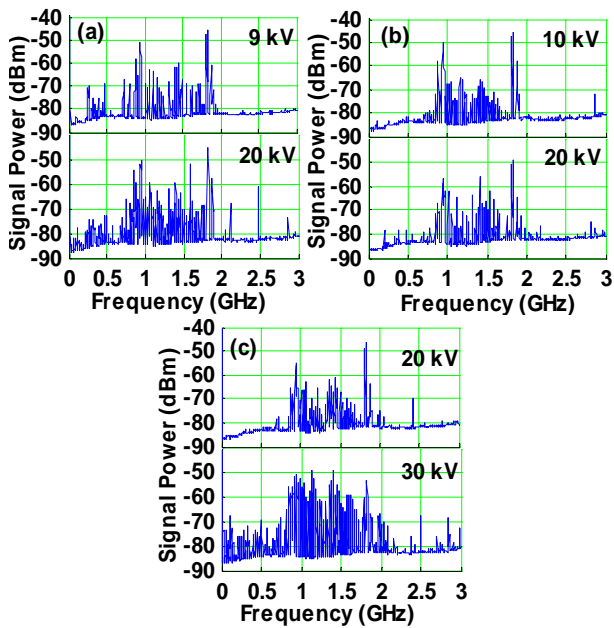

Fig. 10 Typical spectrum analyzer display of UHF signals due to particle movement in transformer oil under different voltages using spectrum analyzer (a) +DC (b) -DC (c) AC

B. Analysis of UHF Signal using Spectrum Analyzer

Fig. 7 shows typical UHF spectra of signals generated by particle movement in transformer oil under AC and DC voltages captured using the spectrum analyzer operating in maximum hold mode for 1 minute. For both AC and DC conditions, signal components in the region of 1 GHz component are predominant. By performing a narrowband measurement of the 1 GHz component alone, it is possible to record each discharge that takes place. Thus a single dominant frequency measurement is helpful for recording the general dynamics of the particle motion through the discharge signals

produced. M.D. Judd et al., demonstrated the important aspects of UHF technique for condition monitoring of transformers [18,19]. Fig. 8 shows typical pulses generated by the particle under AC and DC voltages recorded at a centre frequency of 1 GHz using the spectrum analyzer in zero-span mode with a sweep time of 10 s. The measurements were carried out from the point of inception of particle movement (about 7 kV) by increasing the applied voltage at the rate of 1.8 kV/sec. It could be observed that the discharge process is intermittent and also the magnitude of discharge is different. The cause for it due to charge transfer by the particles to the electrode. Under AC voltages, the magnitude of discharge is high and with increase in voltage, the increase in magnitude of UHF signal not much observed. The major reason is the particle movement occurs locally and consistency in magnitude is high. From these results we observe that the repetition rate of pulses is much higher under AC voltage than DC voltage. Meijer [20] carried out partial discharge studies in transformer using UHF technique and concluded that the technique be sensitive enough to detect PD of 25-30 pC. Raja et al., [21] carried out PD measurement using UHF technique and concluded that UHF PD measurement can detect with good sensitivity even small level of discharges and those buried within the insulation layers. They also have mentioned that acoustic emission technique can detect small level of discharges only when direct line of sight available between discharge source and the sensor.

(ii) Analysis of UHF Signal Generated due to Corona in Oil

Fig. 9 shows characteristic variation in frequency content of UHF signal generated by the corona in transformer oil at different voltage magnitudes, under AC and DC voltage. It is realized that frequency content of the UHF signal generated due to corona under AC and DC voltages is almost the same and are independent of polarity of the applied DC voltage. The results of the study were confirmed using spectrum analyzer output by operating the spectrum analyzer in full span mode for one minute. Fig. 10 shows typical UHF spectra of signals generated by particle movement in transformer oil under AC and DC voltages captured using the spectrum analyzer operating in maximum hold mode for 1 minute.

In the corona generated UHF signal, the dominant frequency is about 1 GHz and zero span analysis was carried out. It is realized that UHF signal generated due to corona at the point of inception have sequential discharges but above certain voltage intensity of discharges increases which could be realized with the zero span analysis plots. Fig. 11 Zero span analysis of UHF signal generated by partial discharged due to particle movement under different voltages. The results of the study clearly indicate that the corona discharges are intermittent type, irrespective of applied voltage. It is also observed that increase in applied voltage shows increase in intensity of corona discharge, which is high with positive polarity compared with negative DC voltage and the magnitude of discharges under AC voltage is nearly same as under positive DC voltage.

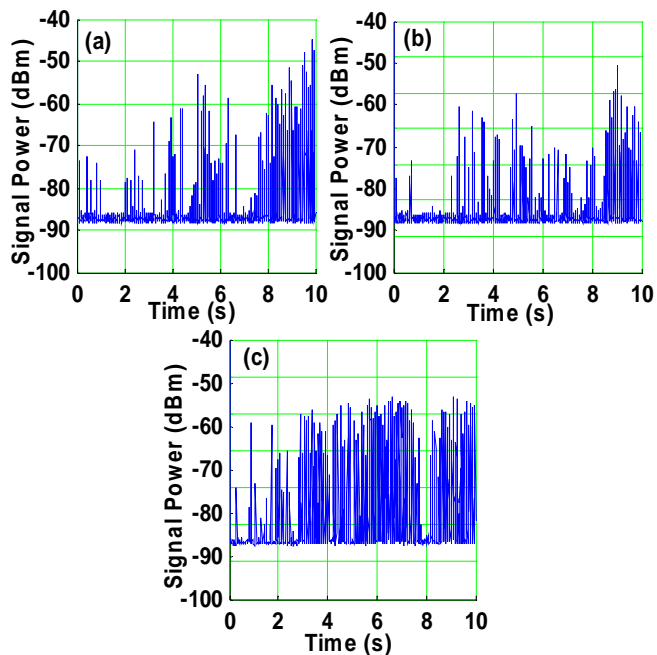

Fig. 11 Zero span analysis of UHF signal generated by partial discharged due to particle movement under different voltages (a) +DC (b)-DC and (c)AC

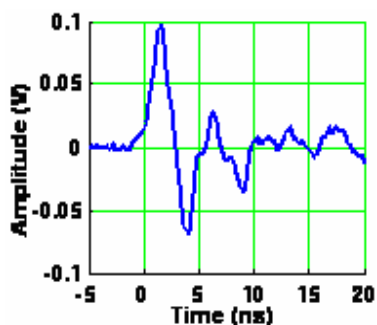

Fig. 12 Typical injected current pulse due to partial discharge formation in transformer oil

Fig. 12 shows typical shape of the injected current pulse formed by partial discharges due to particle movement/corona discharges. The duration of the signal of the first one half cycle is about 4ns, irrespective of the applied voltage, in the case of PD corona activity study. Comparing the UHF signal characteristics generated due to particle movement in transformer oil and corona discharges, the frequency content of the UHF signal generated due to corona has not varied at the point of inception and at higher voltages. In the case of particle movement, increase in applied voltage especially under DC voltages the magnitude of frequency in the range 1-3 GHz is increased.

(iii) Analysis of UHF Signal Generated Due to Partial Discharge Formed Due to Particle Movement and Corona Signal

Fig. 13 shows UHF signal decomposed to different levels. Where S is the actual UHF signal captured, D1-D6 are the different level of its decomposition, A is the approximated signal after final decomposition and RS is the reconstructed signal. The actual signal and the reconstructed signal appear to be the same. It is observed that high and low frequency content are present in the UHF signal acquired. The frequency content of the signal at each level of decomposition is provided in Table I.

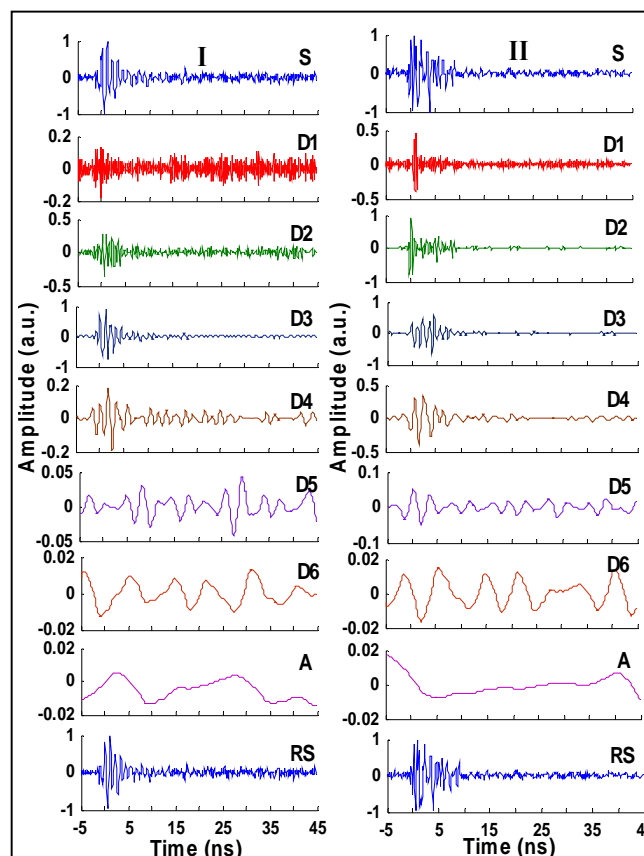

Fig. 13 Typical MRSD analysis of UHF signal (I) UHF signal generated due to particle movement (II) UHF signal generated due to corona D1-D6 are different level of decomposition, (S) actual signal (RS) reconstructed signal

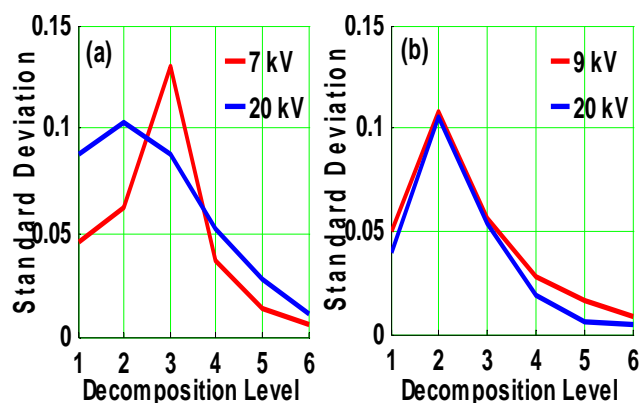

Fig. 14 STD-MRA pattern of MRSD signal obtained from UHF signal generated due to (a) Particle movement (b) Corona

TABLE I
FREQUENCY RANGE AT DIFFERENT LEVEL OF DECOMPOSITION

Level of Decomposition	Frequency Range	Centre Frequency
D1	2.5 GHz – 5 GHz	3.75 GHz
D2	1.25 GHz – 2.5 GHz	1.875 GHz
D3	625 MHz – 1.25 GHz	937.5 MHz
D4	312.5 MHz – 625 MHz	468.75 MHz
D5	156.25 MHz – 312.5 MHz	234.37 MHz
D6	78.125 MHz – 156.25 MHz	117.18 MHz

To arrive at dominant frequency zone, in the present study STD-MRA technique was adopted and from Fig. 14, it is realized that the dominant frequency zone in the UHF signal is the range 625 MHz -1.25GHz for partial discharge formed due to particle movement and for corona signal the dominant peak absorbed in the range 1.25-2.5GHz. Such characteristics observed with particle movement in the high field zone. Thus STD-MRA technique provides finger print identification on characteristics of UHF signal for classifying the partial discharge activity and the corona signal.

V. CONCLUSION

The important conclusions arrived at based on the present investigations are the following

1. It is observed that the levitation voltage of the particle in transformer oil is nearly the same irrespective of polarity of the applied DC voltage
2. It is observed that the UHF signals are generated due to partial discharges caused by the motion of conducting particles and by the corona in transformer oil under AC/DC voltages.
3. Broadband measurement of UHF signals produced due to particle movement in transformer oil under DC voltages, at high applied electric fields, indicates that the frequency content of the signal lies in the entire UHF range of 300 MHz-3GHz.

4. Narrow band measurement of PD signal at 1 GHz, due to particle movement indicates that particle movement in oil gap is highly random. The severity of discharges is high under AC compared with the DC voltages.
5. The duration of injected current pulse due to particle movement/corona under different voltage is about 4 ns.
6. The STD_MRA analysis helps one to understand the energy content of the UHF signal generated. The results of the study clearly indicates the dominant frequency in corona generated signal lies in the frequency band of 0.625-1.25GHz and enhances to the band 1.25-2.5 GHz when the applied electric field is increased in the gap. Similarly the UHF signal generated due to corona under DC voltages, its frequency content lies in the range 1.25-2.5 GHz.
7. The intensity of corona increases with increase in applied voltage (under AC and DC voltages), which could be realized with the zero span analysis of the spectrum analyzer.

ACKNOWLEDGMENT

The author (R.S) wish to thank Dr. M.D. Judd, University of strathclyde for his kind support extended to carryout the present work. Also he wishes to thank central power research institute, Bangalore, for their funding through RSOP scheme for the project entitled “Partial discharge studies in transformers using UHF technique”.

REFERENCES

- [1] IEEE Trial use standard general requirements and test code for oil immersed HVDC converter transformers, IEEE Std C57.129-1999, IEEE USA.
- [2] W. Kennedy, Recommended dielectric tests and test procedures for converter transformers and smoothing reactors, IEEE Trans. On Power Delivery, 1(3), (1986) pp161-166.
- [3] R. Tobazeon, Behaviour of spherical and cylindrical particles in an insulating liquid subjected to a DC uniform field, Conduction and Breakdown in Dielectric Liquids,1993., ICDL '93., IEEE 11th International Conference on 19-23, PP.415 – 420, 1993.
- [4] M.D. Judd, O. Farish and B.F. Hampton, Excitation of UHF signals by partial discharges in GIS, IEEE Trans. On dielectrics and electrical insulation, Vol-3, pp213-228, 1996.
- [5] M.D. Judd, O. Farish and B.F. Hampton, Excitation of UHF signals by partial discharges in GIS, IEEE Trans. On dielectrics and electrical insulation, 3(2), (1996), pp213-228.
- [6] G.P. Cleary and M.D. Judd, UHF and current pulse measurement of partial discharge activity in mineral oil, IEE Proc.- Sci. Meas. Technol. 153(2), (2006), pp47-54.
- [7] A Cavallini, G.C. Montanari, F. Ciani, Analysis of partial discharge phenomena in paper oil insulation system as a basis for risk assessment evaluation, IEEE International Conference on Dielectric Liquids, pp241 – 244, 2005.
- [8] A Convery and M D Judd, “Measurement of propagation characteristics for UHF signals in transformer insulation materials”, Proc. 13th Int. Symp. on High Voltage Engineering (Delft), August 2003.
- [9] M.D. Judd and O. Farish, A pulsed GTEM system for UHF sensor calibration, IEEE Trans. on Instrumentation and measurement, Vol-47, pp875-880, 1998.
- [10] National Grid Company plc, Capacitive couplers for UHF partial discharge monitoring, Technical guidance note: TGN(T)121, Issue 1, Jan 1997.
- [11] O. Rioul and M. Vetterli, Wavelet and Signal Processing, IEEE Signal Processing Magazine, pp. 14 – 38, 1991.

- [12] Mallat, S. G., A Theory for Multi resolution signal decomposition: The wavelet representation. IEEE Transactions on Pattern Analysis and Machine Intelligence, Vol. 11, No. 7 (1989), pp. 674- 693.
- [13] A.M. Gaouda, M.M.A. Salama, M.R. Sultan and A.Y. Chikhani, Power Quality Detection and classification using Wavelet- Multi resolution Signal Decomposition, IEEE Trans. on Power delivery, Vol. 14, No. 4, pp. 1469 – 1476, 1999.
- [14] M. Krins, H. Borsi and E. Gockenbach, Influence of carbon particle on the breakdown voltage of transformer oil, 12th Int. conf. On conduction and breakdown in dielectric liquids (ICDL) Rome, Italy, pp296-299, 1996.
- [15] S. Birlasekaran, The movement of a conductive particle in transformer oil in AC fields, IEEE Trans. on Electrical Insulation, 28(1), (1993), pp9-17.
- [16] S. Birlasekaran, The measurement of charge on single particles in transformer oil, IEEE Trans. on Electrical Insulation, 26(6), (1991) pp1094-1103.
- [17] Lucian Dascalescu, Michaela Mihaiescu, Robert Tobazeon, Modeling of conductive particle behavior in insulating fluids affected by DC electric fields, IEEE Trans. On Industry Applications, 34(1), (1998), pp66-74.
- [18] M.D. Judd, Li Yang, Ian B.B. Hunter, Partial discharge monitoring for power transformers using UHF sensors Part-1: Sensors and signal interpretation, IEEE Electrical Insulation magazine, 21(2), (2005), pp5-14.
- [19] M.D. Judd, Li Yang, Ian B.B. Hunter, Partial discharge monitoring for power transformers using UHF sensors Part-2: Field Experience, IEEE Electrical Insulation Magazine, 21(3), (2005) 5-13.
- [20] Sander Meijer, Edward Gulski, Johan J. Smit, H.F. Reijnders, sensitivity check for UHF Partial discharge detection in power transformers, Conf. Record of the 2004 IEEE int. conf. on Electrical Insulation, pp58-61, Sept. 2004, Indianapolis, USA.
- [21] K. Raja and S. Lelaidier, Experience with UHF partial discharge measurement, Proc of 14th Int. conf. on dielectric liquids, pp239-241, 2002.