

SFCL Location Selection Considering Reliability Indices

Wook-Won Kim, Sung-Yul Kim and Jin-O Kim †

Abstract— The fault current levels through the electric devices have a significant impact on failure probability. New fault current results in exceeding the rated capacity of circuit breaker and switching equipments and changes operation characteristic of overcurrent relay. In order to solve these problems, SFCL (Superconducting Fault Current Limiter) has rising as one of new alternatives so as to improve these problems. A fault current reduction differs depending on installed location. Therefore, a location of SFCL is very important. Also, SFCL decreases the fault current, and it prevents surrounding protective devices to be exposed to fault current, it then will bring a change of reliability. In this paper, we propose method which determines the optimal location when SFCL is installed in power system. In addition, the reliability about the power system which SFCL was installed is evaluated. The efficiency and effectiveness of this method are also shown by numerical examples and the reliability indices are evaluated in this study at each load points. These results show a reliability change of a system when SFCL was installed.

Keywords— Superconducting Fault Current Limiter, Optimal Location, Reliability

I. INTRODUCTION

The fault current of modern power system has become so large because power generating facilities and mass transformers has been increased by the continuous power demand increment and an Impedance of a distribution system has become lower. New fault current results in exceeding the rated capacity of circuit breaker and switching equipments and changes operation characteristic of overcurrent relay [1]. In order to solve these problems, several ways have been proposed. Firstly, it is to replace the existing circuit breakers by those of larger capacity. However, it occur huge cost to replace a great number of existing circuit breakers. Another one is installing serial reactor but it occurs the loss of power. SFCL (Superconducting Fault Current Limiter) has rising as one of new alternatives so as to improve these problems. SFCL is power electronic device which is quenched when electric currents are more than the critical value flowing to the superconductor. SFCL can detect fault currents as quick as possible without additional equipments. And it does not occur

the loss of power. because it has zero impedance at normal state. A fault current reduction effect differs depending on installed location. Therefore, a location of SFCL is very important. Also, SFCL decreases the fault current, and it prevents surrounding protective devices to be exposed to fault current, it then will bring a change of reliability. In this paper, we propose an algorithm which determines the optimal location when SFCL is installed in distribution system. In addition, the reliability about the power system which SFCL was installed is evaluated. Case study is preceded using modified RBTS system [2]. An optimal location of the SFCL is selected by using the proposed method at this paper through case study. The efficiency and effectiveness of this algorithm are also shown by numerical examples and the reliability indices are evaluated in this study at each load points. These results show a reliability change of a system when SFCL was installed.

II. OPTIMAL IMPEDANCE SELECTION OF SFCL

The installation of SFCL is possible to apply to the 2nd winding side of transformer, the feeder or the bus-tie. However it is general to install the 2nd winding side of transformer or 2nd winding side of transformer of mass electric power generating facilities because of easy management or effect of fault current reduction. In this paper, study is processed as installing the 2nd winding side of transformer or 2nd winding side of transformer of DG (Distributed Generation). If the impedance of SFCL is too small, it has weak effect of the fault current reduction. On the other hand too large impedance of SFCL has problem which is difficult to differ between fault current and load current. Therefore the impedance of SFCL has to be chosen as appropriate value. One of the purposes of using SFCL is re-using of the existing circuit breaker. Fault current shall decrease in the range that doesn't exceed the maximum instantaneous current rating permission of fault current of a circuit breaker. Therefore, we can determine the minimum impedance of a circuit breaker from (1).

† Dept. of Electrical Engineering, Hanyang University, Korea
(jokim@hanyang.ac.kr)

$$i(t)_{ij}^{CB} = \frac{V^m}{Z_{ij}} \sin(\omega t + \alpha - \theta_{ij}) - \frac{V^m}{Z_{ij}} e^{-\frac{R}{L}t} \sin(\alpha - \theta_{ij}) \quad (1)$$

$$(Z_{ij} = Z_{ij}^s + Z_{Tr} + Z_{SFCL})$$

The first term is the steady state sinusoidal component. The second term is a dc transient component known as dc offset which decays exponentially [3]. The magnitude of dc component depends on the instant of application of the voltage to the circuit, as defined by the angle α . $\theta_{ij} = \tan^{-1} \omega L / R$. $i(t)_{ij}^{CB}$ means fault current through the circuit breaker located between bus i and j . V^m is maximum voltage of fault point. and Z_{ij} is equivalent impedance of fault point. Z_{Tr} is the impedance transformer and Z_{SFCL} is the impedance of SFCL. The maximum fault current occurs in a circuit breaker when fault came out to the neighborhood of circuit breaker. Therefore, in this paper, fault point which is only neighborhood of circuit break is considered. (1) can be rewritten about impedance of SFCL. And it is as follows.

$$Z_{SFCL} = \frac{V_m}{i(t)_{\max}^{CB}} \sin(\omega t + \alpha - \theta_{ij}) - \frac{V_m}{i(t)_{\max}^{CB}} e^{-\frac{R}{L}t} \sin(\alpha - \theta_{ij}) - Z_{ij}^s - Z_{Tr} \quad (2)$$

$(i(t)_{\max}^{CB})$ has maximum value, when $\alpha - \theta = \pi / 2$. If we assume $\omega L \gg R$, $\theta \approx \pi / 2$. Therefore the impedance of SFCL is expressed as follows.

$$Z_{SFCL} = \frac{V_m}{i(t)_{\max}^{CB}} + \frac{V_m}{i(t)_{\max}^{CB}} e^{-\frac{R}{L}t} - Z_{ij}^s - Z_{Tr} \quad (3)$$

t is time and fault current has maximum value when t is 1/4 cycle. Fault current that flowing through the circuit breaker is different according to positions of SFCL. Therefore, the optimal impedance will be different according to positions of SFCL. When SFCL is installed one of candidates, the required minimum impedance about each circuit breaker is shown in Fig.1.

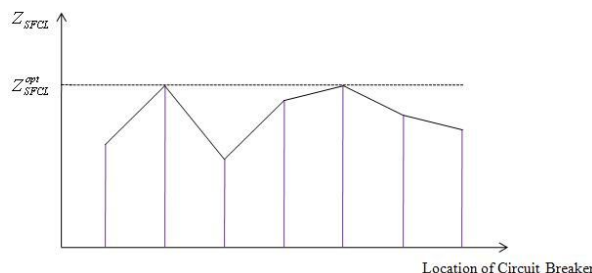

Fig. 1 Location of circuit breaker

Fig. 1 shows by optimal impedance of SFCL which doesn't exceed instantaneous current rating of all circuit breakers. When SFCL is installed one of candidates. Optimal impedance of SFCL only needs to determine in the range that doesn't exceed instantaneous current rating of all circuit breakers. Therefore, SFCL should be to have impedance more than the minimum value of all circuit breakers. However, it is desired economically that SFCL has minimum impedance.

III. CHANGE OF DISTRIBUTION RELIABILITY USING SFCL

A. Breaker Failure Probability

Probability of protection failure of circuit breaker is decreased because Fault current through circuit breaker is decreased by SFCL. The probability of protection failure of circuit breaker by fault current through the circuit breaker is shown in Fig. 2 [4], [5].

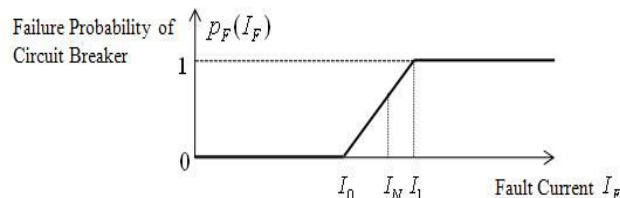

Fig. 2 Failure probability of circuit breaker

$p_F(I_F)$ provides the failure probability of the circuit breaker for each value of the fault current I_F is the fault current flowing to the circuit breaker. I_0 and I_1 are each the lower and the upper failure threshold current. And I_N is the rating of circuit breaker. If the fault current exceeds the upper failure threshold ($I_F > I_1$), the breaker will fail to interrupt the current. For I_F between I_0 and I_1 , it is assumed that the probability of failure linearly transitions from zero to one. Failure probability of breaker due to fault currents is a conditional probability. If there is a fault on the breaker protection zone and the magnitude of fault currents exceeds the upper failure threshold of the breaker ($I_F > I_0$); as shown in

Fig.1 the breaker will fail to interrupt I_F with the probability $p_F(I_F)$. Therefore, the failure probability density of a circuit breaker can be calculated from (4) when fault current occurred to a protective zone of a circuit breaker.

$$CPD = f(i(t)_{ij}^{CB}) p_F(i(t)_{ij}^{CB}) \quad (4)$$

Where λ is total failure rate on a protective zone of a circuit breaker. And in terms of the Exponential distribution, the failure probability of protective zone of a circuit breaker during a period of time t is:

$$P_F = Q(t) = 1 - R(t) = 1 - e^{-\lambda t} \quad (6)$$

Therefore when fault current occurred to a protective zone of a circuit breaker, the failure probability of a circuit breaker is obtained as.

$$P_{CF} = P_{C/F} \times P_F = P_{C/F} \times (1 - e^{-\lambda t}) \quad (7)$$

B. Failure Rate of Transformer

Main fault cause of transformer is due to transient overvoltage disturbance, overheating winding insulation breakdown, insulating bushing breakdown and etc. main fault cause of a transformer. Fault current is a large portion of those causes [6]. Fault current is decreased very much, if SFCL is installed to the 2nd winding side of transformer, and reliability of transformer will be expected to increase. We can draw the frequency of fault current flowing to the transformer from total failure rate of system. If the failure probability of transformer cause of fault current is P_T , Change of failure rate of transformer caused by installed SFCL is as follows.

$$\lambda'_{Tr} = \lambda_{Tr} \left(1 - P_T \times \frac{N'_0}{N_0}\right) \quad (8)$$

λ_{Tr} is failure rate of transformer and λ'_{Tr} is failure rate of transformer changed by SFCL. P_T is failure probability by fault current to exceed rating among the transformer fault causes. N_0 is the number of fault current which exceed rating through the transformer during years. N'_0 is the number that fault current is decreased by SFCL within rating.

IV. RELIABILITY EVALUATION OF DISTRIBUTION SYSTEM

The failure rate of protective devices is changed by the location of SFCL and distribution reliability is also changed.

Optimal location is selected by evaluation of distribution reliability using changed failure rate. SAIFI and SAIDI is used for evaluation of distribution reliability [7], [8]. Algorithm for the optimal location of SFCL can be shown in Fig. 3.

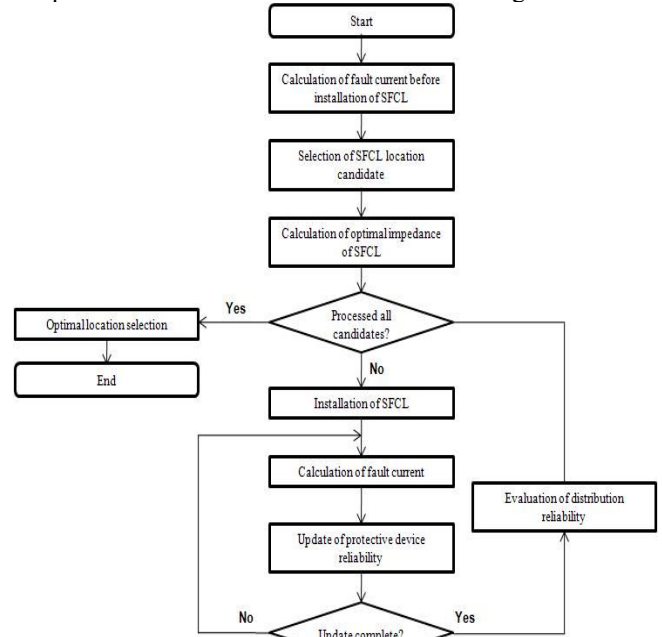

Fig. 3 Algorithm for optimal location selection of SFCL

V. CASE STUDY

Modified RBTS System is composed considering interconnection of distributed generator, and it is shown in Fig. 4. Failure rate of Load point, transmission line, transformer, circuit breaker and bus bar are only considered for simplifications of a case study. Line switch is assumed perfect without failure rate.

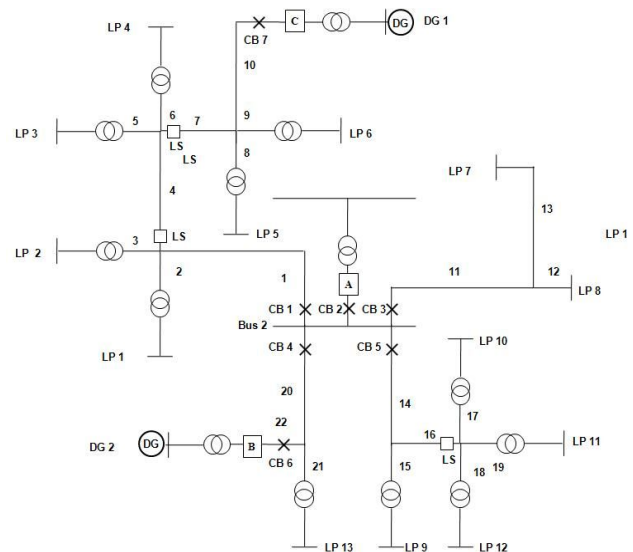

Fig. 4 Modified RBTS system

Candidates of SFCL location is determined A, B and C that is 2nd winding side of transformer or 2nd winding side of transformer of DG. Table I shows customer data and table II shows Reliability parameters for of Modified RBTS System.

TABLE I
CUSTOMER DATA

Load Point	Load(MW)	Number of customer	Type
LP 1	2.5	210	residential
LP 2	2.5	210	residential
LP 3	2.5	210	residential
LP 4	4	10	commercial
LP 5	4	10	commercial
LP 6	4	10	commercial
LP 7	6	1	industrial
LP 8	5	1	industrial
LP 9	2.5	210	residential
LP 10	2.5	210	residential
LP 11	3	300	residential
LP 12	3	300	residential
LP 13	2.5	210	residential

TABLE II
RELIABILITY PARAMETERS FOR SYSTEM

Component	Failure rate	Repair time
154/22.9[kV]	0.015[f/yr]	15
22.9/0.230[kV]	0.015[f/yr]	10
22.9[kV] bus	0.001[f/yr]	2
22.9[kV] lines	0.065[f/yr]	5
Circuit Breaker	0.006[f/yr]	4
SFCL	0.005[f/yr]	4

A. Optimal Impedance Calculation of SFCL

Maximum current rating of circuit breaker which is used in KEPCO is 31.5kA in 22.9kV distribution system and optimal impedance of SFCL is calculated using this value and above formula. Optimal impedance of SFCL are each $j5.24$, $j7.86$ and $j20.96$. If SFCL is installed at candidate A, B and C. The effect of fault current reduction of each circuit break when SFCL is installed each candidate is shown in Fig. 5.

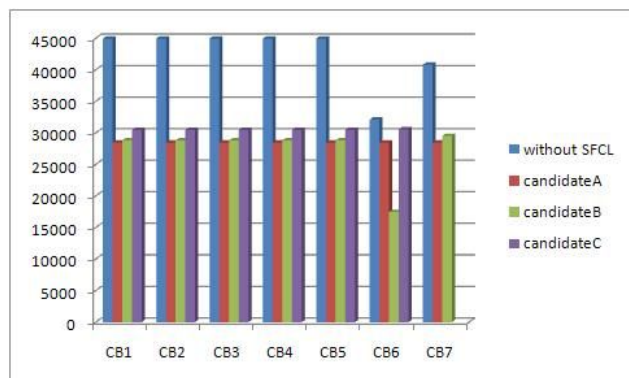

Fig. 5 Fault current reduction by SFCL

B. Reliability Calculation of Protective Devices

Failure rate of transformer due to fault current is assumed 10percent. The change of failure rate of transformer caused by installed SFCL was calculated using (8). Fault current was calculated using MATLAB with Newton Raphson. Also the fault probability of circuit was calculated using proposed method. Table III is Reliability enhancement of Protective Devices by SFCL.

TABLE III
RELIABILITY ENHANCEMENT OF PROTECTIVE DEVICES

	Without SFCL	Candidate A	Candidate B	Candidate C
154/22.9[kV]	0.015[f/yr]	0.0135	0.0137	0.0138
22.9/0.230[kV]DG1	0.015[f/yr]	0.0136	0.0138	0.0136
22.9/0.230[kV]DG2	0.015[f/yr]	0.0136	0.0136	0.0139
CB1	0.006[f/yr]	0.004024	0.004192	0.004197
CB2	0.006[f/yr]	0.004024	0.004192	0.004197
CB3	0.006[f/yr]	0.004024	0.004192	0.004197
CB4	0.006[f/yr]	0.004024	0.004192	0.004197
CB5	0.006[f/yr]	0.004024	0.004192	0.004197
CB6	0.006[f/yr]	0.005385	0.003264	0.005516
CB7	0.006[f/yr]	0.00448	0.004493	0.004302

C. Evaluation of Distribution System Reliability

Change of Distribution System Reliability is evaluated using failure rate of circuit breaker and transformer which is calculated above. SAIFI and SAIDI have been used for Evaluation of Distribution System Reliability. Table IV shows change of reliability according to the location of SFCL.

TABLE IV
RELIABILITY OF DISTRIBUTION SYSTEM

	Without SFCL	Candidate A	Candidate B	Candidate C
SAIFI	0.2793	0.2494	0.2524	0.2527
SAIDI	1.6853	1.4957	1.5186	1.5416

SFCL decreases the fault current, and it prevents surrounding protective devices to be exposed to fault current, thereby decreasing the failure rate of devices. As a result, SFCL will improve the reliability of distribution system in spite of its own failure rate. Improvement of reliability is shown in Fig. 6.

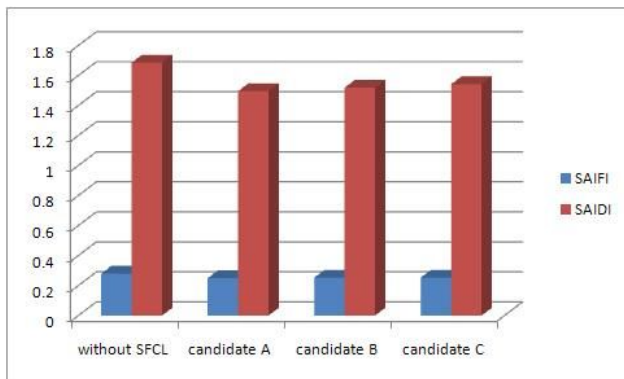

Fig. 6 Reliability of distribution system

[8] Roy Billinton and Ronald N. Allan, "Reliability Evaluation of Engineering Systems", Plenum Press, 1996.

The largest improvement of Reliability is shown in Fig. 6 when SFCL is installed to candidate A. This is shown that the candidate1 affect more improvement of decreasing fault current than other candidates. Therefore, it is desired that SFCL is installed to candidate A considering reliability when SFCL is introduced in the distribution system. Also proposed method can be used when multiple SFCLs is introduced.

VI. CONCLUSION

SFCL has rising one of new alternatives to improve large fault current problems. However it is necessary to select the optimal impedance of SFCL and the optimal location of SFCL. In this paper, optimal impedance of SFCL considering rating capacity of circuit breaker and SFCL location selection considering distribution reliability is proposed. Case study shows that the enhancement of reliability of distribution system by SFCL. And optimal location has been selected among candidates which has the highest reliability. The proposed method in this paper is useful to select optimal location of SFCL when SFCL is installed in the distribution system which is interconnected with distributed generator.

REFERENCES

- [1] L. Ye, L. Z. Lin, and K. P. Juengst, "Application studies of superconducting fault current limiters in electric power systems" *IEEE Trans. Superconductivity*, vol. 12, no. 1, pp.900–903, March 2002.
- [2] Ronald N. Allan; Roy Billinton; I.Sjarief, L.Goel, K.S.So "A Reliability Test System for Educational Purposes Basic Distribution System Data and Results", *IEEE Trans. Power System*, vol.6, no.2, pp.813-820, 1991.
- [3] Hadi Saadat, "Power System Analysis", Mc Graw Hill, 2004.
- [4] M. R. Haghifam, A. Ghaderi, and M. Abapour, "Enhancement Circuit Breaker Reliability by Using Fault Current Limiter", in Proceedings of *IEEE PES 09 Conference*,
- [5] Q. Binh Dam and A. P. Sakis Meliopoulos, "Reliability Implications of Increased Fault Currents and Breaker Failures", *iREP 2007*, Charleston, SC, USA, August 2007.
- [6] James W. Aquilino, "Report of Transformer Reliability Survey-Industrial Plants and Commercial Buildings", *IEEE Trans. Industry Applications*, vol. I A-19, no. 5, pp 858-866, September/October 1983.
- [7] Roy Billinton and Ronald N. Allan, Reliability "Evaluation of Power System", Plenum Press, 1996.