

Comparison of Eurocodes EN310 and EN789 in Determining the Bending Strength and Modulus of Elasticity of Red Seraya Plywood Panel

S.F. Tsen and M. Zamin Jumaat

Abstract—The characteristic bending strength (MOR) and mean modulus of elasticity (MOE) of tropical hardwood red seraya (*Shorea* spp.) plywood were determined using European Standard EN310 and EN789. The thickness of the test specimen was 4.0mm, 7.0mm, 9.0mm, 12.0mm and 15.0mm. The experiment found that the MOR of red seraya plywood in EN310 is about 12% to 20% and 7% to 24% higher than EN789 whereas MOE were about 28% to 41% and 30% to 36% lower than those obtained from EN 789 for test specimens parallel and perpendicular to the grain direction. The linear regression shows that MOR and MOE for EN789 is about 0.8 times less and 1.5 times more than EN310. The experiment also found that the MOR and MOE of EN310 and EN789 also depend on the wood species that used in the experiment.

Keywords—Bending strength, Modulus of elasticity, EN310, EN789

I. INTRODUCTION

CONSTRUCTION and industrial plywood has traditionally been made from softwoods, but the current Wood Handbook has listed and classified the strength of a large number of hardwoods that are suited for a similar purpose [1]. Red seraya (*Shorea* spp.), a tropical hardwood also known as light red meranti, is one of the hardwoods listed. Red seraya species is widely used in plywood as it is easily machined, dried without degradation and its smooth surface is suited to all kind of finishes. However, there have been few studies on the strength properties of plywood made from Malaysian red seraya timber originating from Sabah. The strength properties of plywood are normally determined using different testing standards in different region of the world. In Europe, structural wood-based panels are regulated by European Standards BS EN13986, Wood-based panels for used in construction - Characteristics, evaluation of conformity and marking. While in US, structural panels have to comply with the Performance Standard PS 2-07 for wood-based structural-use panels (NIST 04) where ASTM method were adopted. In European Standards [2], there are two testing methods that can be used to determine the strength properties for plywood, EN310

S.F. Tsen is with Department of Civil Engineering, Faculty of Engineering, University of Malaya, 50603, Kuala Lumpur, Malaysia. (phone: 6012-811-3750; e-mail: sandra_tsf@yahoo.com).

M. Zamin Jumaat is with Department of Civil Engineering, Faculty of Engineering, University of Malaya, 50603, Kuala Lumpur, Malaysia. (phone: 603-7967-5203; e-mail: zamin@um.edu.my).

(three-point bending test) and EN789 (four-point bending test). Generally, the strength properties obtained using different testing methods are considered to be equivalent. However, the different in test set up may affect the strength properties of wood-based panel. Thus, the objective of this paper is to compare the MOR and MOE between EN310 and EN789 using red seraya plywood panel.

II. MATERIAL AND METHOD

A. Material

Logs of red seraya from the Sabah rainforest were harvested and manufactured into 1200mm by 2400mm plywood sheets, with a nominal thickness of 4.0 mm (3 plies), 6.5 mm (5 plies), 9.0 mm (7 plies), 12.0 mm (9 plies) and 15.0 mm (11 plies).

B. EN789 (Four-Point Bending Test)

The plywood was cut according to the cutting plan (Fig 1) in the four-point bending test method of EN789 for the determination of mechanical properties of wood based panels. The cutting plan shows a batch of four plywood panels for specimen sampling. There were a total of 8 batches, with each batch consisting of 4 panels of plywood. One test piece parallel (0) to the grain and one perpendicular (90) to the grain were cut from each panel. The specimens for the bending test in each direction were not sampled from the same position in different panels of the same batch; only one specimen was sampled from each panel. The width of the test specimen was 300 ± 5 mm and the length was $(l_2 + l_3)$ as depicted in Fig. 2, which shows the arrangement of the bending test according to EN789.

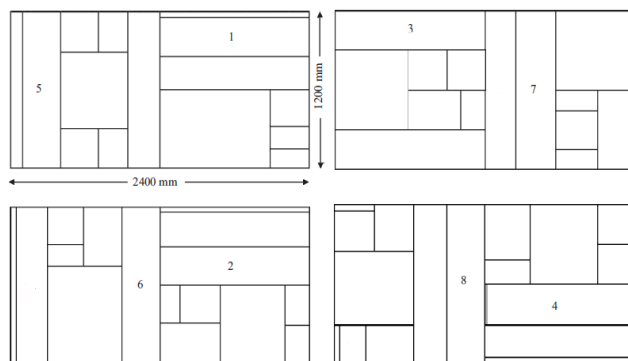

Fig. 1 The cutting plan shows on a sample of four panels for sampling of specimens according to EN 789. Test specimen no.1 to no.4 is longitudinal grain direction while test specimens no.5 to no.8 is transverse grain direction

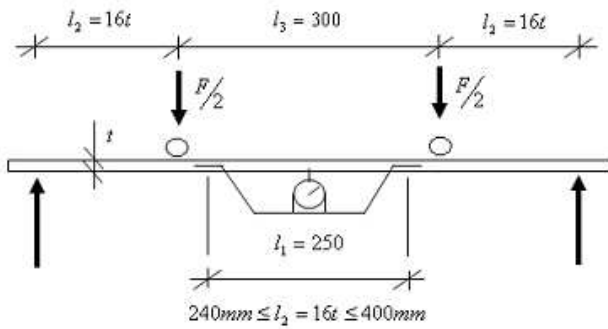

Fig. 2 Arrangement for the bending test, Dimensions are in mm

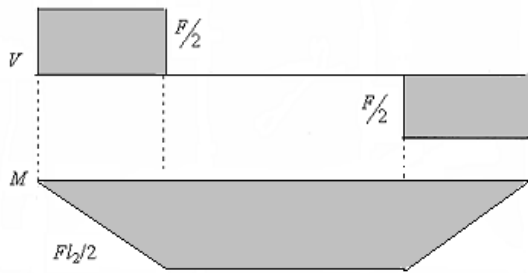

Fig. 3 Shear force (V) and bending moment (M) diagram of EN789.

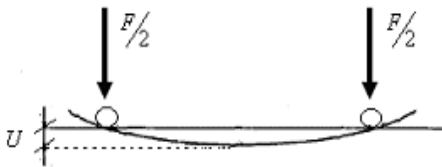

Fig. 4 Measurement of deflection (U) of EN789

The deflection of the mid-span was measured and the load-deflection curves were plotted. The MOR of the test piece was calculated from the following formula:

$$MOR = \frac{3F_{max}l_2}{bt^2} \quad (1)$$

Where, MOR is bending strength (N/mm^2), F_{max} is maximum load (N), l_2 is 16 times thickness (mm), b is the width of test specimen (mm), t is thickness of test specimen (mm) as depicted in Fig. 2. The MOE of the test piece was calculated from the following formula:

$$MOE = \frac{3(F_2 - F_1)l_1^2l_2}{4bt^3(U_2 - U_1)} \quad (2)$$

where $(F_2 - F_1)$ is the increment of load on the straight line portion of the load-deflection curve, where F_1 was

approximately 10% and F_2 was approximately 40% of the maximum load F_{max} , $(U_2 - U_1)$ is the increment of deflection corresponding to $(F_2 - F_1)$ in load-deflection curve. The MOR used in this paper was the 5-percentile value while MOE was the mean value of the results for 8 batches.

C. EN310 (Three-Point Bending Test)

There were a total of 12 panels of plywood for each thickness in the cutting plan of EN310 (Fig. 5). Each plywood panel was cut into two groups of bending test specimens, 6 pieces of parallel and 6 pieces of perpendicular grain directions. The test specimen is rectangular with width b , (50 ± 1) mm and length is 20 times the nominal thickness (t) plus 50mm. The test specimens are conditioned to a constant mass in an atmosphere with relative humidity $(65 \pm 5)\%$ and temperature $(20 \pm 2)^\circ C$. A cylindrical loading head with diameter (30.0 ± 0.5) mm was placed parallel to the supports. The test specimen was set between the adjustable supports with the centre point under the load as shown in Fig. 6. The load that applied to the test specimen was adjusted so that the maximum load reached within (60 ± 30) s throughout the test.

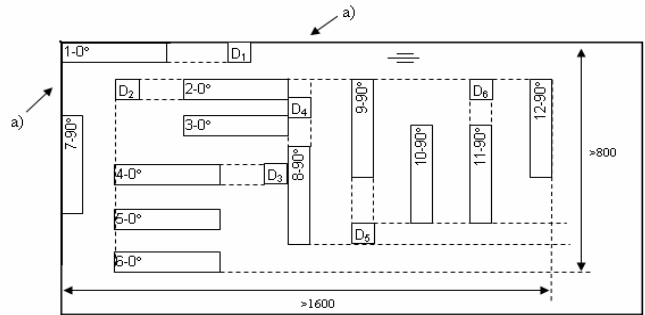

Fig. 5 The cutting plan of EN310, Test piece number 1 to 6 indicates the orientation of face plies parallel to the span whereas test piece number 7 to 12 indicates the orientation of face plies perpendicular to span. The dimensions are in millimetres. Symbol a) means outer edge trimmed

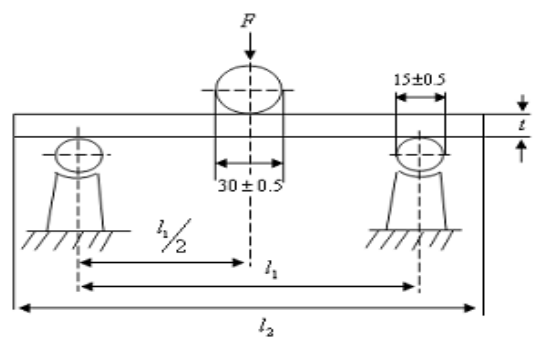

Fig. 6 Bending apparatus setup. Dimensions are in mm

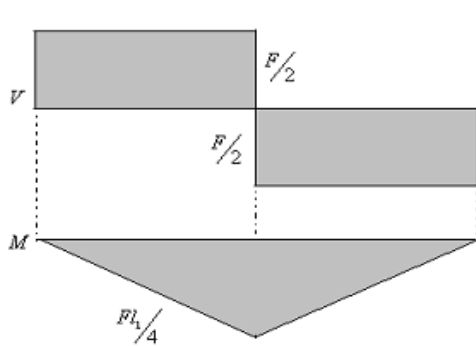

Fig. 7 Shear force (V) and bending moment (M) diagram of EN310

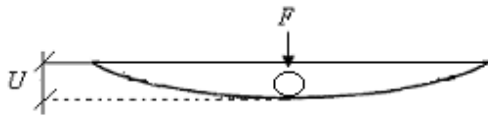

Fig. 8 Measurement of deflection (U) of EN310

The deflection of the mid-span was measured and the load-deflection curves were plotted. The MOR of the test piece was calculated from the following formula:

$$MOR = \frac{3F_{max}l_1}{2bt^2} \quad (3)$$

Where F_{Max} is maximum load (N), l_1 is the distance between the centres of two supports (mm), b is the width of the test pieces (mm), t is the thickness of the test pieces (mm) as depicted in Fig. 6. The modulus of elasticity (MOE) of each test pieces is given by formula:

$$MOE = \frac{l_1^3(F_2 - F_1)}{4bt^3(U_2 - U_1)} \quad (4)$$

Where l_1 , b and t is as defined in above and depicted in Fig. 6. $(F_2 - F_1)$ is the increment of load on the straight line portion of the load-deflection curve, where F_1 was approximately 10% and F_2 was approximately 40% of the maximum load F_{max} , $(U_2 - U_1)$ is the increment of deflection corresponding to $(F_2 - F_1)$ in load-deflection curve.

The MOR for all test specimens were analyzed using the 5-percentile value and the MOE for all test specimens were analyzed using mean values.

III. RESULTS AND DISCUSSION

TABLE I
STRENGTH AND STIFFNESS PROPERTIES FOR RED SERAYA (*SHOREA SPP*)
USING EN789

t (mm)	Plies	MOR (Nmm ⁻²)		MOE (Nmm ⁻²)	
		0	90	0	90
4	3	48.9 (3.3)	9.5 (4.0)	15202 (4.1)	-
6.5	5	42.9	18.0	9686	3539

			(4.0)	(3.6)	(4.5)	(3.2)
9	7	41.5 (3.5)	26.3 (3.5)	8904 (4.1)	4659 (3.7)	
12	9	39.9 (2.1)	27.7 (3.0)	8319 (4.6)	5146 (2.5)	
15	11	37.7 (4.0)	29.4 (2.5)	7782 (3.3)	5402 (4.2)	

^aMOR values are the 5-percentile of 32 readings. MOE values are the means of 32 readings, with the % coefficients of variation in brackets. t – thickness, 0 – Parallel to wood grain direction, 90 – Perpendicular to wood grain direction. Result of 4mm 90 is not displayed due to large deflection.

TABLE II
STRENGTH AND STIFFNESS PROPERTIES FOR RED SERAYA (*SHOREA SPP*)
USING EN310

t (mm)	Plies	MOR (Nmm ⁻²)		MOE (Nmm ⁻²)	
		0	90	0	90
4	3	56.3 (5.7)	11.2 (10.2)	9010 (6.3)	642 (18.6)
6.5	5	50.5 (5.0)	20.2 (6.4)	6454 (5.1)	2280 (8.5)
9	7	46.5 (3.0)	28.1 (4.6)	5807 (2.9)	3058 (6.1)
12	9	48.0 (3.5)	34.3 (4.5)	6008 (5.1)	3589 (4.6)
15	11	42.5 (1.8)	33.0 (2.9)	5253 (2.4)	3687 (1.5)

^aMOR values are the 5-percentile of 144 readings. MOE values are the means of 144 readings, with the % coefficients of variation in brackets. t – thickness, 0 – Parallel to wood grain direction, 90 – Perpendicular to wood grain direction.

TABLE III
DIFFERENCE OF MOR AND MOE BETWEEN EN310 AND EN789 IN
PERCENTAGE (%)

t (mm)	Plies	MOR (Nmm ⁻²)		MOE (Nmm ⁻²)	
		0 (%)	90 (%)	0 (%)	90 (%)
4	3	-15.2	-17.3	40.7	-
6.5	5	-17.8	-12.1	33.4	35.6
9	7	-12.0	-6.7	34.8	34.4
12	9	-20.4	-23.6	27.8	30.3
15	11	-12.6	-12.2	32.5	31.7

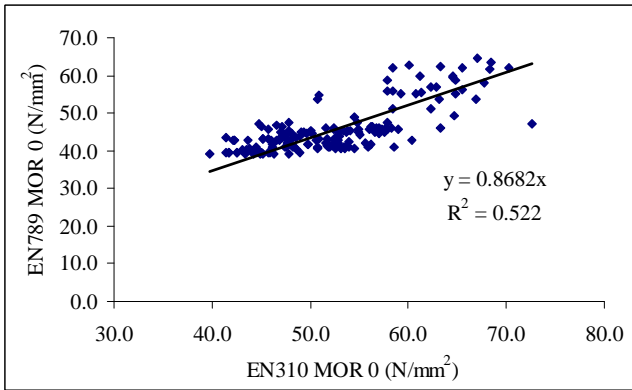

Fig. 9 Linear regression lines illustrating the dependence of MOR 0 for EN789 to EN310

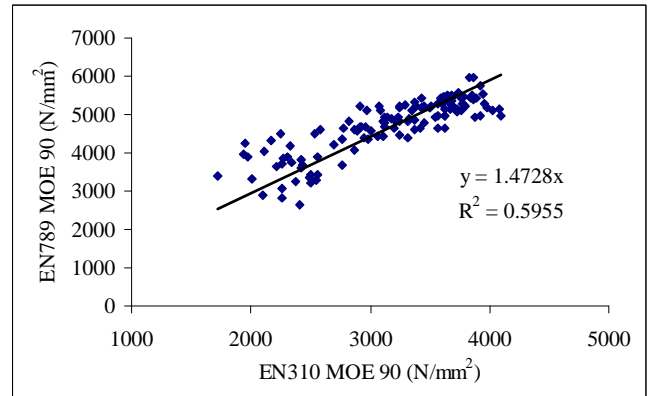

Fig. 12 Linear regression lines illustrating the dependence of MOE 90 for EN789 to EN310

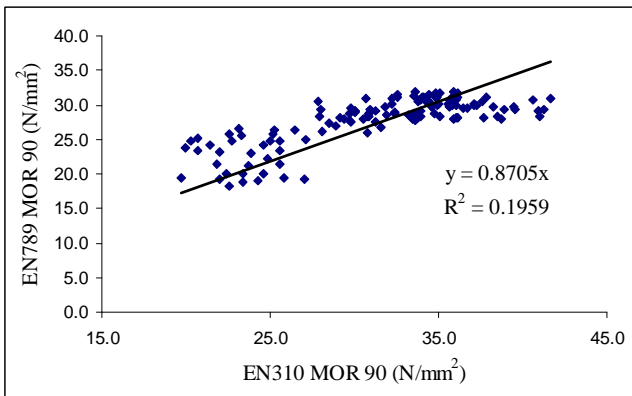

Fig. 10 Linear regression lines illustrating the dependence of MOR 90 for EN789 to EN310

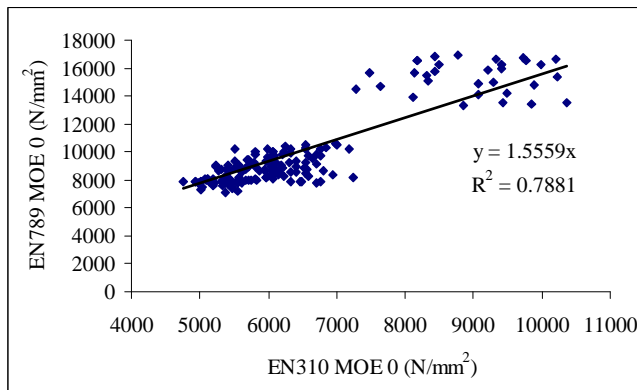

Fig. 11 Linear regression lines illustrating the dependence of MOE 0 for EN789 to EN310

The MOR and MOE of three-point bending and four-point bending test have been studied experimentally. Table I and II shows the MOR and MOE of 5 different plywood thickness obtained by EN310 and EN789.

In general, the MOR obtained by three-point bending test is higher than four-point bending test. The overestimation of MOR of three-point bending is due to the evaluation point of bending strength and also the depth and length of test specimen. The evaluation point of bending strength for three point bending test is located pointwise at the mid-span whereas the four point bending test is located at the weakest point between the loading noses [5].

Thus, the strength properties obtained by the three-point bending test are usually larger than those obtained by the four-point bending test [6]. The MOR values obtained by EN310 are larger than EN789. The overestimation of MOR for EN310 compared to EN789 was about 12% to 20.4% and 6.7% to 23.6%, for specimens parallel and perpendicular to grain, respectively.

It was expected that MOE under three-point bending test would be smaller than four-point bending [6]. In four-point bending test, the evaluation point of deformation was located in the uniform bending moment area, this could highly reduced the influence of deformation induced by shear force. In addition, the span/depth ratio for four-point bending test was larger than three-point bending. Hence, the MOE of four-point bending would be larger than three-point bending test. Reference [7] had reported that a three-point bending test had underestimates about 19% the MOE value in relation to a four-point bending test. This is due to the influence from the shear effect and the indentation effect of the loading head and the supports are neglected. Table III shows the underestimation (%) of MOE for EN310 compare to EN789. The EN310 had significantly underestimated the MOE in range 27.8% to 40.7% and 30.3% to 35.6% for both test specimens parallel and perpendicular, respectively.

The MOR and MOE of EN789 were correlated with MOR and MOE of EN310, respectively. The correlation was tabulated in Fig. 9 to Fig. 12. The linear correlation is considered to be significant as the data was in large amount. Reference [8] had reported that the MOR of Birch plywood for EN789 is about 0.7 times of EN310 whereas the MOE is about 1.3 times of EN310 for both parallel and perpendicular test specimen. In comparison with the current results, the MOR for EN789 is 0.9 times of EN310 whereas the MOE is 1.5 times of EN310 for both parallel and perpendicular test specimen. It was also observed that the coefficient correlation (R^2) for parallel test specimens is stronger than perpendicular test specimens for both MOR and MOE.

IV. CONCLUSION

Plywood tested under EN310 had MOR larger and MOE smaller than EN789. In addition to the already known dependence of MOR and MOE to the location of evaluation point, radius of support and loading noses, a biasing effect of different wood species was observed in this study. We found that the different wood species could influence the MOR, MOE and correlation between EN310 and EN789.

REFERENCES

- [1] J. A. Youngquist, "Chapter 10 Wood-based Composites and Panel Products," in *Wood Handbook—Wood As An Engineering Material*, Forest Service United States: Forest Products Laboratory, 1999, pp. 10-1 – 10-31.
- [2] European Committee for Standardization, *EN 13986:2004 Wood-based Panels for Use In Construction – Characteristics, Evaluation Of Conformity And Marking*, 2004.
- [3] European Committee for Standardization, *EN 789 Timber Structures – Test Methods – Determination of Mechanical Properties of Wood Based Panels*, 2004.
- [4] European Committee for Standardization, *EN310 Determination Of Modulus Of Elasticity In Bending And Of Bending Strength*, 1993.
- [5] D. F. Adams, L. A. Carlsson, and R. B. Pipes, *Experimental characterization of advanced composite materials*. 3rd edition. Boca Raton, CRC Press, 1993.
- [6] H. Yoshihara and D. Nakano, "Flatwise bending properties of commercial Lauan five-ply wood and medium-density fibreboard obtained by the methods based on three major standards," *Bulletin Faculty of Science and Engineering, Shimane University, Japan*, 2011.
- [7] L. Brancheriau, H. Bailleres and D. Guitard, "Comparison between modulus of elasticity values calculated using 3 and 4 point bending tests on wooden samples," Springer-Verlag. *Wood Science and Technology*, Vol. 36, pp. 367-383, 2002.
- [8] H. Tuherm and K. Zudrgas, "Determination of characteristic bending properties of birch plywood by EN310 test method," in *2006 Proc. 2th Meeting of Nordic Baltic Network in Wood Material Science & Engineering (WSE) Conf.*, Stockholm, Sweden.