

# Access Control System: Monitoring Tool for Fiber to the Home Passive Optical Network

Aswir Premadi, Mohammad Syuhaimi Ab. Rahman, Mohamad Najib Moh. Saupe, and Kasmiran Jumari

**Abstract**—An optical fault monitoring in FTTH-PON using ACS is demonstrated. This device can achieve real-time fault monitoring for protection feeder fiber. In addition, the ACS can distinguish optical fiber fault from the transmission services to other customers in the FTTH-PON. It is essential to use a wavelength different from the triple-play services operating wavelengths for failure detection. ACS is using the operating wavelength 1625 nm for monitoring and failure detection control. Our solution works on a standard local area network (LAN) using a specially designed hardware interfaced with a microcontroller integrated Ethernet.

**Keywords**—ACS, monitoring tool, FTTH-PON.

## I. INTRODUCTION

IN the optical fiber communication era, it is expected that broadband network provision will require thousands of optical fibers to be accommodated in a central office (CO) for the optical access network. Optical fiber is capable of delivering bandwidth-intensive integrated, voice, data and video services at distance beyond 20 km in the subscriber access network. All transmission in a PON is performed between an optical line terminal (OLT) and optical network unit (ONU). The OLT resides in the central office, connecting the optical access network to the metro back-bone, and the ONU is located the end-user location.

Optical fiber maintenance is a very important issue to be consider in a developing a high quality and reliable PON. The long feeder line in a PON is a vulnerable part of the network; when unprotected, a break of it puts the whole PON out of service. One types of network protection have been described in ITU-T Recommendation G.983.1, as shown in Fig. 1. Protection of the feeder fiber only by a spare fiber over which the traffic can be rerouted by means of optical switches. After detection of a failure in the primary fiber and switch-over to the spare fiber, also reranging has to be done by the PON transmission convergence (TC) layer.

Aswir Premadi is with the Computer and Network Security Research Group Dept. of Electrical, Electronic, and Systems Engineering University Kebangsaan Malaysia, 43600 UKM Bangi, Selangor, Malaysia, on leave from the Institut Teknologi Padang, Indonesia (e-mail: aswirp@vlsi.eng.ukm.my).

Mohammad Syuhaimi Ab. Rahman is with the Computer and Network Security Research Group Dept. of Electrical, Electronic, and System Engineering Universiti Kebangsaan Malaysia, 43600 UKM Bangi, Selangor, Malaysia. He joined the Institute of Micro Engineering and Nanoelectronics (IMEN) in 2003. He is currently a senior lecturer in UKM (corresponding author to provide phone: 603-8921-6448; fax: 603-8921-6146; e-mail: syuhaimi@vlsi.eng.ukm.my).

To support various optical communication network services expected in the coming years, there has been much effort to develop a fiber to the home (FTTH) passive optical network (PON). FTTH-PON offers many advantages such as high-speed, large capacity, and low cost [1]. However, despite its advantages, a typical FTTH-PON with the feeder fiber architecture does not have self-monitoring capability. Preventive monitoring on the optical level can save a considerable amount of operational cost.

Monitoring tool for detecting failure in optical fiber networks is traditionally set up on dark fiber as this provides good balance between material cost, system provisioning effort and fault detection success rate. Most monitoring systems used for physical fault detection and positioning employ optical time domain reflectometer (OTDR) [2]. In a PON topology, fiber fault detection by OTDR is not suitable because the Rayleigh back-scattered light from different branches cannot be distinguished at the OTDR. To overcome this drawback, several methods have been proposed [3], [4].

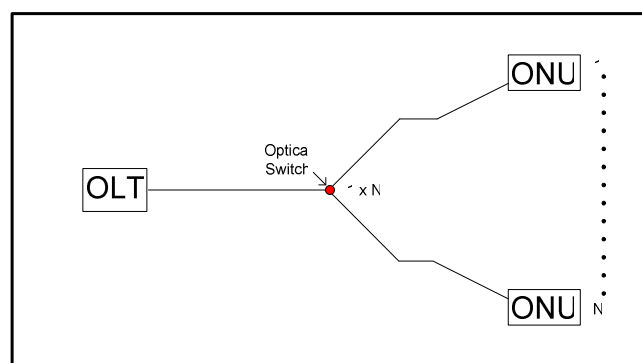

Fig. 1 Protection Scheme: feeder fiber

In this study, we demonstrate a monitoring tool for optical fiber fault in FTTH-PON. To detect and monitor the fault on the physical layer, the access control system (ACS) is used in the OLT at central office (CO). In this monitoring, the OLT can distinguish transmission fiber fault and upstream transmitter failure in the ONU

An optical switch can uses to monitoring and measurement. The device has optimized mechanical latching system combined with a prism, and used in specialized systems such as optical network. A switch that enables signals in optical fibers or integrated optical circuits to be selectively switched

from one circuit to another, or may be used for alternate routing of an optical transmission path, e.g., routing around a fault [5].

As technology advances, PIC microcontroller is manufactured by Microchip Technology Inc. Currently they are one of the most popular microcontroller, used in many applications. It is a self-contained computer-on-a-chip that integrates a microprocessor, input and output ports, memory for program and data storage, an internal clock, and one or more peripheral devices such as timers, counters, analog-to-digital converters, communication facilities, watchdog circuits and special hardware features. Among all the PIC microcontroller families, especially the PIC18F97J60 of devices feature an integrated Ethernet controller module. It was integrated MAC and 10Base-T PHY, making Ethernet communication possible. The PIC18F97J60 is the superset device in 100 pin Ethernet MCU, with 8 Kb on buffer RAM dedicated for Ethernet communication providing a full state machine so as to prevent overloading the core when sending or receiving packet data. The 8-bit microcontroller has enjoyed a tremendous growth in embedded systems applications. It is a fine chip that is easy to program by means of a simple device attached to the parallel or serial port or Ethernet port. With the 128Kb of code space available on the PIC18F97J60, a TCP/IP stack can easily be accommodated

while leaving plenty of program memory for the application, which is one of the important factors in such a system [6],[7] was chosen due to its variety of hardware modules needed for monitoring scheme FTTH-PON.

## II. HARDWARE DESIGN

### A. Access Control System

ACS is focusing on providing survivability through the protection against failure by means of dedicated and shared protection that is applied in FTTH-PON. ACS is used to monitor the status of the working and restoration fibers. ACS recognized the types of failure and sent the activation signal to the related optical switch according to the activated protection mechanisms. Each ONU is connected to splitter output terminal by two fibers; working line and protection line through optical switch that is controlled by ACS. The function of optical switch is to switch the signal to the protection line when failure occurs in the working line. The route depends on the restoration mechanism that is activated according to the types of failure. When the failure occurs in the working line, the first ACS will switch the signal to the local protection line and the second ACS will be activated simultaneously to switch the signal back to the transmission line.

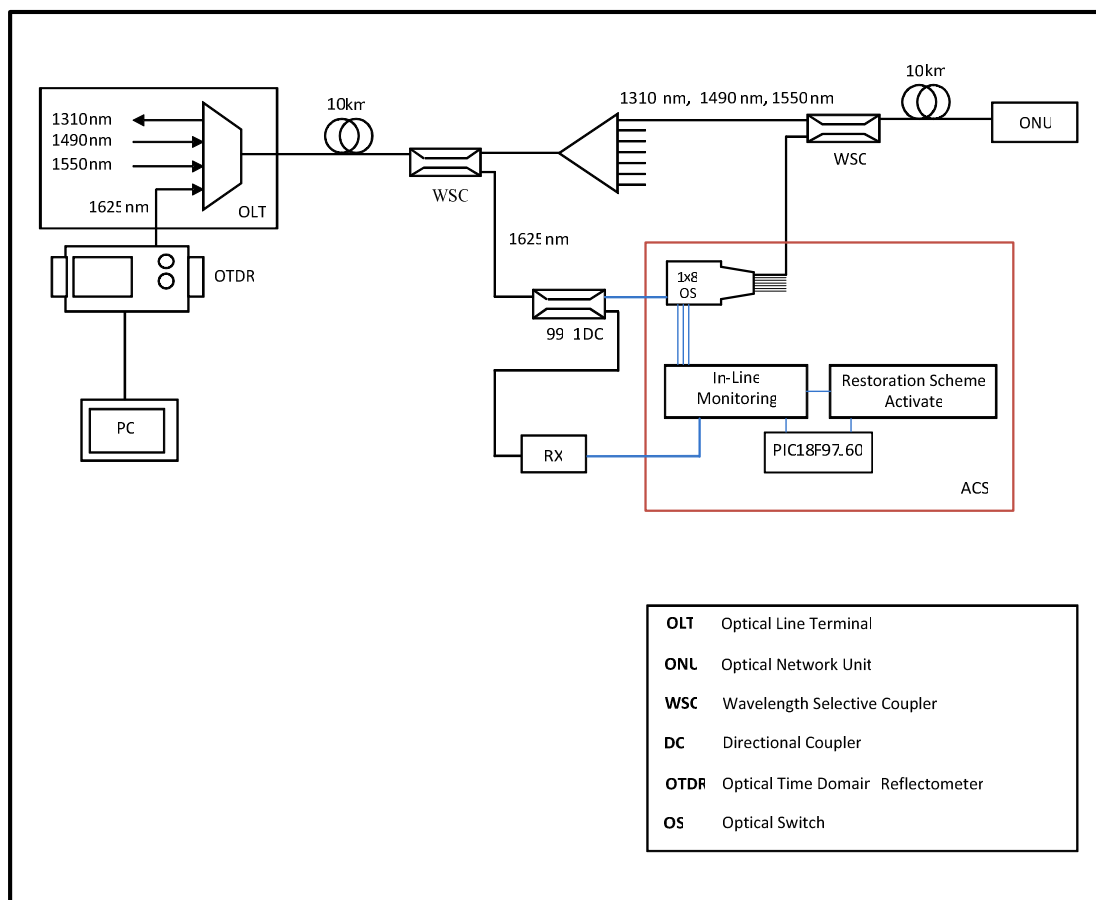

Fig. 2 Access Control System for FTTH-PON

The detailed diagram for ACS scheme is shown in Fig. 2. To locate a failure without affecting the transmission services to other customers, it is essential to use a wavelength different from the triple-play services operating wavelengths for failure detection. ACS integrated Ethernet is using the operating wavelength 1625 nm for failure detection control and in-service troubleshooting. The triple-play services operating wavelengths (1310 nm, 1490 nm and 1550 nm) are multiplexed with a testing signal (1625 nm) from OTDR. The OTDR is installed in the OLT and will be connected to a PC to display the troubleshooting result.

When four kinds of signals are distributed, the testing signal will be split up by the Wavelength Selective Coupler (WSC) which is installed before the splitter. The WSC only allow the testing signal at 1625 nm to enter into the taper circuit and reject all unwanted signals (1310 nm, 1490 nm and 1550 nm) that contaminate the OTDR measurement. The downstream signal will go through the WSC which in turn connected to splitter before it reaches the ONUs. The distance between the OLT and ONU is about 20 km. On the other hand, the testing signal which is demultiplexed by WSC will be split up again in power ratio 99:1 by using directional coupler to activate the ACS. The 99% 1625 nm signal will then be configured by using optical splitter which each output is connected to single line of ONU. The operational of optical switch is controlled by ACS system that is activated by 1% of 1625 nm signal.

The principal limitation to live fiber monitoring at 1625 nm, will come from the spontaneous Raman scattering noise that reaches the OTDR port. In case of bidirectional transmission, OTDR power and transmission power levels may require adjustments so that effect remains negligible.

Access Control System (ACS) is control the status of any optical switch device connected to it and transmits its status to the PIC18F97J60. Its then arranges the information in the form of a packet and transmits it over the LAN using the embedded Ethernet system. It consists of four major parts, PIC18F97J60 microcontroller, 1x8 optical switches, In-Line Monitoring (ILM) and Restoration Scheme Activate (RSA). Generally, ACS is integrated in a single system, which also includes splitter, OTDR and personal computer (PC). Tapping 3% of the downstream and upstream signal by using coupler can recognize the status of feeder section and drop section. If breakdown occurs in feeder section, ACS will send a signal to activate the dedicated protection scheme. But if the breakdown is the detected in drop section, ACS will recognize the related access line by the 3% tapped signal that is connected to every access line. The activation signal is then sent to active the dedicated protection scheme. But if fault is still not restored, the shared protection scheme will be activated. The monitoring signal section is responsible for sensing fault and its location whereas generation of activation of signal is sent by activation section in ACS [8].

### B. Ethernet Module

The Ethernet Module System is designed to transmit the status of optical switch device connected to our system over

the LAN or internet connectivity applications through Ethernet connection.

The PIC18F97J60 microcontroller with integrated Ethernet is a complete connectivity solution, including full implementations of both Media Access Control (MAC) and Physical Layer transceiver (PHY) modules. Two pulse transformers and a few passive components are all that are required to connect the microcontroller directly to an Ethernet network.

A simple block diagram of the module is shown in Fig. 3.

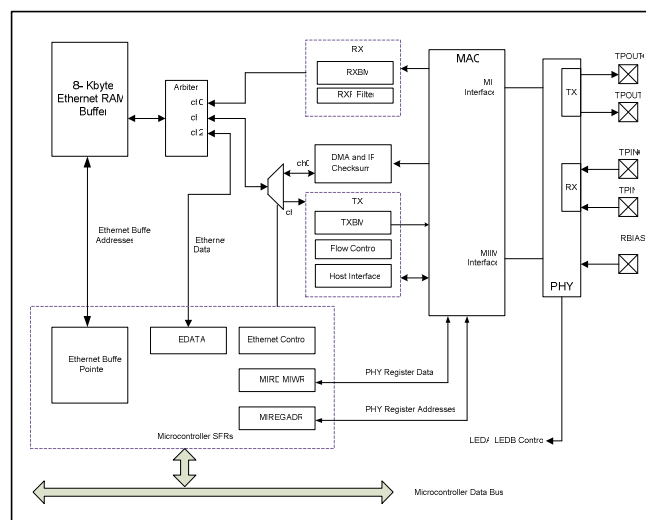

Fig. 3 Block diagram for Ethernet module system

The Ethernet module consists of the five major functional blocks:

- The PHY transceiver module that encodes and decodes the analog data that is present on the twisted-pair interface and sends or receives it over the network
- The MAC module that implements IEEE 802.3 compliant MAC logic and provides Media Independent Interface Management (MIIM) to control the PHY.
- An independent, 8-Kbyte RAM buffer for storing packets that have been received and packets that are to be transmitted.
- An arbiter to control access to the RAM buffer when requests are made from the microcontroller core, DMA, transmit and receive blocks.
- The register interface that functions as an interpreter of commands and internal status signals between the module and the microcontroller's SFRs.

To complete the Ethernet interface, the Ethernet module requires several standard components to be installed externally. These components should be connected as shown in Fig. 4. The internal analog circuitry in the PHY module requires that an external resistor (2.26 kΩ) be attached from RBIAS to ground. The resistor influences the TPOUT+/- signal amplitude. It should be placed as close as possible to the chip with no immediately adjacent signal traces to prevent noise capacitively coupling into the pin and affecting the

transmit behavior. It is recommended that the resistor be a surface mount type.

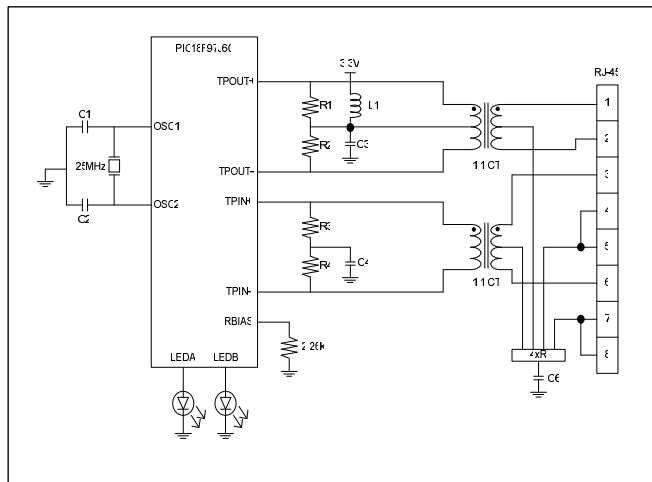

Fig. 4 External components for Ethernet

The Ethernet module is designed to operate at 25MHz. This is provided by the primary microcontroller clock either with a 25MHz crystal connected to the OSC1 and OSC2 pins or an external clock source connected to the OSC1 pin. Its uses three independent memory spaces for its operations:

- An Ethernet RAM buffer which stores packet data as it is received and being prepared for transmission.
- A set of 8-bit Special Function Registers (SFRs), used to control the module and pass data back and forth between the module and microcontroller core.
- A separate set of 16-bit PHY registers used specifically for PHY control and status reporting.

Now at this point it must be mentioned that the connection to Ethernet through the RJ-45 connector requires the standard twisted pair for transmission or the TX+/TX- and also the twisted pair for RX+ and RX-.

### III. EXPERIMENTAL RESULTS

Fig. 2 shows the experimental setup to demonstrate the proposed fault monitoring in FTTH-PON. For ACS, coupler, and WSC were used at the CO. We used the 10km single mode fiber to connect the OLT with the optical splitter. To implement a single fiber FTTH-PON, we as signed operating wavelength 1625 nm for the downstream and monitoring signals. In this experiment, the upstream traffic was not considered. The ONU were signed for the upstream traffic and the fault monitoring signals, respectively, and transmitted to the OLT. The OTDR was used as the broadband light source. The wavelength selective couplers (WSCs) in both the OLT and the ONU separate the wavelength 1625 nm monitoring signals. At the OLT, the upstream data signal and the reflected monitoring signal assigned to each ONU separated by the WSC were received by the ACS. In case of an upstream transmitter failure, the pin receiver not receive the data signal, but the monitoring ACS can detect the power of the

monitoring signal without intermission. If a distribution fiber cut occurs, the pin receiver and the monitoring ACS can not receive the data signal and detect the optical power, respectively.

TABLE I  
WORKING CONDITION FOR OPTICAL SWITCH

Route Optical Switch	Input	Output Pin		
		D1	D2	D3
Line 1	000	0	0	0
Line 2	001	0	0	1
Line 3	010	0	1	0
Line 4	011	0	1	1
Line 5	100	1	0	0
Line 6	101	1	0	1
Line 7	110	1	1	0
Line 8	111	1	1	1

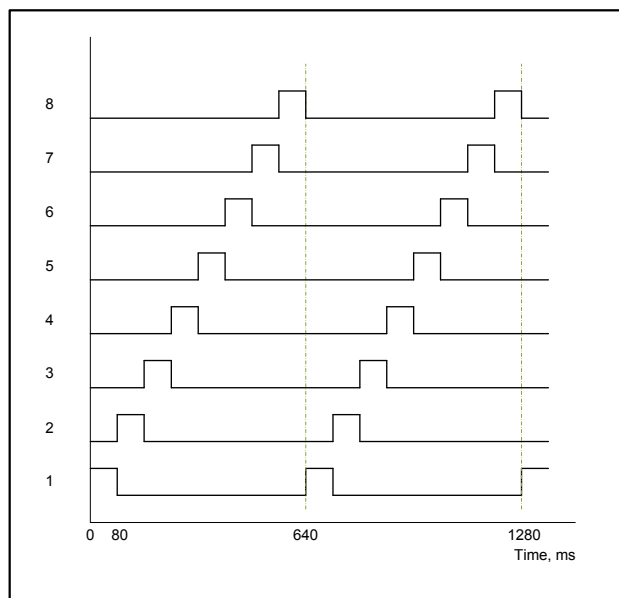

Fig. 5 Working Condition

ACS send 3 bits signal to monitor route line of optical switch, and send or received 1 bits signal ready to activated optical switch. The function of optical switch is to switch the signal to the protection line when failure occurs in the working line. The route depends on the restoration mechanism that is activated according to the types of failure. When the failure occurs in the working line, the first ACS will switch the signal to the local protection line and the second ACS will be activated simultaneously to switch the signal back to the transmission line.

To show the performance of the proposed optical switch, Table I shows the working condition of optical switch of the proposed real-time fiber monitoring. Therefore, by monitoring of the optical switch route of the proposed ACS scheme can be detected the line faults.

TABLE II  
FAULT CONDITION FOR OPTICAL SWITCH

Route Optical Switch	Input	Activated	Output Pin			Remark
			D1	D2	D3	
Line 1	000	0	0	0	0	Fault
Line 2	001	1	0	0	1	Used
Line 3	010	1	0	1	0	Used
Line 4	011	0	0	1	1	Fault
Line 5	100	1	1	0	0	Used
Line 6	101	1	1	0	1	Used
Line 7	110	1	1	1	0	Used
Line 8	111	1	1	1	1	Used

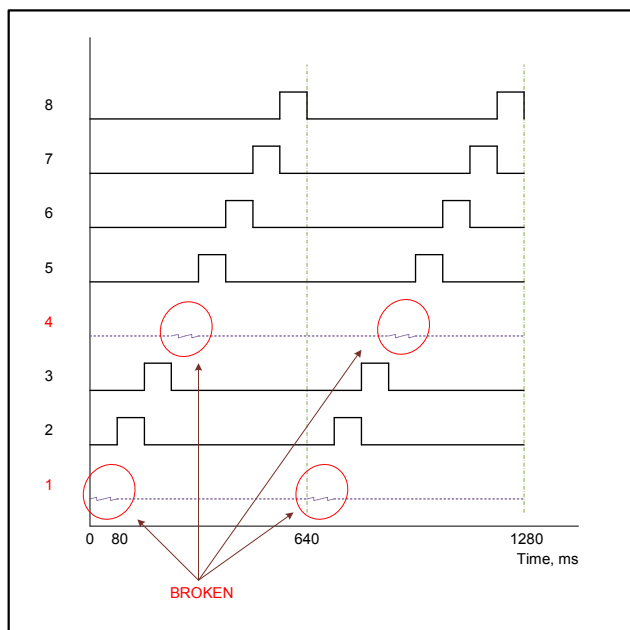

Fig. 6 Fiber fault condition

To demonstrate the fault monitoring function, we simulated a fiber cut on the path and transmitter failure using a 1x8 optical switch. Table II shows the fault monitoring characteristics for failure at the line fiber network. And to simulate the fault identification process, Fig. 6 shows the curve of optical power output of the proposed fiber line monitoring when the fiber line 1 and 4 are broken by the external force application. The solid line indicates the normally operation from fiber line 2-3, 5-8, and the dotted line shows the fiber fault behavior when the fiber line 1 and 4 are disconnected. The experimental results show that our proposed scheme is very feasible.

The status of each line is automatically updated to a web server which can access by remote monitor via internet or LAN. At the CO, the network operator can read the status of each fiber line timely through some web browsers such as Internet Explorer, as shown a Fig. 7.

The monitoring scheme of a FTTH-PON using ACS has been proposed, we have designed an efficient and cost-effective system for PON appliances. It was successfully identified without affecting communication signal

transmission, with the specification available a complete system can be made with 24 man-hours. It will to improve the service reliability and reduce the restoration time and maintenance cost.

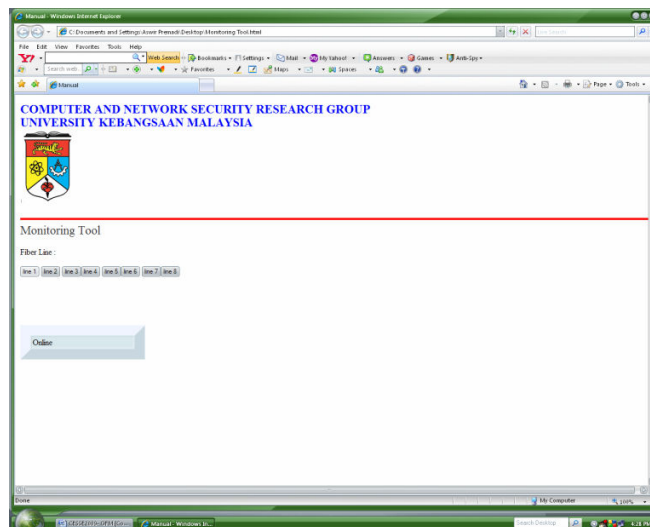

Fig. 7 Webpage monitoring tool

#### REFERENCES

- [1] T. Koonen, "Fiber to the Home/Fiber to the Premise: What, Where, and When?," *Proceedings of the IEEE*, 2006, pp.911-934..
- [2] H. Chen, M. Leblanc, O. Plomteux, "Live-Fiber OTDR Testing: Traffic and Measurement Impairments", EXFO Electro-Optical Engineering Inc., 2007, pp.1-7.
- [3] A. A. A. Bakar, M. Z. Jamaludin, F. Abdullah, M. H. Yaacob, M. A. Mahdi, M. K. Abdullah, "A New Technique of Real-Time Monitoring of Fiber Optic Cable Networks Transmission", *Optics and Lasers in Engineering*, vol. 45, 2007, pp.126-130.
- [4] H. Yeh, S. Chi, "Fiber Fault Monitoring Technique for Passive Optical Networks Based on Fiber Bragg Gratings and Semiconductor Optical Amplifier", *Optics Communication*, Vol. 257, 2006, pp.306-310
- [5] The Omron Electronic Component Website, 2008 [Online]. Available: <http://components.omron.eu/>
- [6] The Microchip Website, 2008 [Online]. Available: <http://www.microchip.com>
- [7] PIC18F97J60 Family Data Sheet, Microchip Technology Inc., 2008, Doc. no. DS39762DC.
- [8] M. S. A. Rahman, M. T. M. Yusof, "Development of Optical Multifunctional Switch," *Wireless and Optical Communication Network, 2008, WOCN '08, 5<sup>th</sup> IFIP International Conference*, pp.1-7.



**Aswir Premadi** was become Lecturer at Institut Teknologi Padang, Indonesia, before working toward the M.Sc. degree in Electrical, Electronics, and Systems Engineering at Universiti Kebangsaan Malaysia, until 2008. Currently he is Research Engineer of Computer and Network Security Research Group Universiti Kebangsaan Malaysia. His fields of interest are access control system for fiber to the home network.



**Mohammad Syuhaimi Ab. Rahman** was received the B.Eng, M.Sc, and PhD degree from Department of Electrical, Electronic, and Systems Engineering, Universiti Kebangsaan Malaysia, Bangi, Malaysia, in 2000, 2003, and 2007, respectively.

He joined the Institute of Micro Engineering and Nanoelectronics (IMEN) in 2003. He is currently a senior lecturer in UKM, Malaysia. He is also an associated research fellow of IMEN since 2006. His current research interests are in the area of photonic networks and optical communication technologies such as optical security nodes, device fabrication, photonic crystal, laser technology, active night vision, plastic optical fiber, fiber to the home, fiber in automotive and optical code-division multiplexing (OCDM). The current and interest project is development of survivability and smart network system for customer access network then can be called as an intelligent FTTH (*i*-FTTH), collaborated with Ministry of Science, Technology and Innovation (MOSTI) of the Government of Malaysia.



**Kasmiran Jumari** is a professor in the Department of Electrical, Electronics and Systems Engineering, UKM. He received the B.Sc. and M.Sc. in Physics and Instrument Design from UKM and University of Aberdeen in 1976 and 1978, respectively. In 1985, he holds a PhD degree in Electronics from University of Kent.

His research is in the area of security system, intrusion detection system, signal processing, image processing and computer communications networks. Currently, he is also hold a position as an associate research fellow of Institute of Space Science (ANGKASA) UKM.



**Mohamad Najib Mohamad Saupe** is Research Student of Computer and Network Security Research Group Universiti Kebangsaan Malaysia. His fields of interest are access control system for fiber to the home network.