

Robust Steam Temperature Regulation for Distillation of Essential Oil Extraction Process using Hybrid Fuzzy-PD plus PID Controller

Nurhani Kasuan, Zakariah Yusuf, Mohd Nasir Taib, Mohd Hezri Fazalul Rahiman, Nazurah Tajuddin, Mohd Azri Abdul Aziz

Abstract—This paper presents a hybrid fuzzy-PD plus PID (HFPP) controller and its application to steam distillation process for essential oil extraction system. Steam temperature is one of the most significant parameters that can influence the composition of essential oil yield. Due to parameter variations and changes in operation conditions during distillation, a robust steam temperature controller becomes nontrivial to avoid the degradation of essential oil quality. Initially, the PRBS input is triggered to the system and output of steam temperature is modeled using ARX model structure. The parameter estimation and tuning method is adopted by simulation using HFPP controller scheme. The effectiveness and robustness of proposed controller technique is validated by real time implementation to the system. The performance of HFPP using 25 and 49 fuzzy rules is compared. The experimental result demonstrates the proposed HFPP using 49 fuzzy rules achieves a better, consistent and robust controller compared to PID when considering the test on tracking the set point and the effects due to disturbance.

Keywords—Fuzzy Logic controller, steam temperature, steam distillation, real time control.

I. INTRODUCTION

THE quality of essential oil is a crucial matter in many industries or applications such as aromatic and fragrance[1], food and flavors[2], cosmetic[3], insect repellent and pesticides[4] and etc. The essential oil from plant materials contains fragile aromatic molecules that can be easily annihilate or modified by any changes during extraction process. Even a subtle difference in extraction process conditions can give significant effect on the oil quality. In many studies, there are several parameters are concerned that have effect to extraction yield. These parameters are temperature, pressure, distillation time, chemical composition and particle size [5,6]. However, this paper is concentrating on steam temperature variation as a controlled parameter since it is one of the most significant parameter in distillation process [7]. In operating the extraction, applying high temperature or long duration exposure of heat to botanical plant that being extract, it may cause the extracted oil yield to experience thermal degradation [3,8]. Consequently, quality of oil's chemical composition properties will reduce as it affects the oil's aromatic profiles and its physical color.

Authors are with Universiti Teknologi MARA, Shah Alam, Malaysia.

A dedicated extraction technique implemented in this study is steam distillation process. This method is popular for many essential oil plants extractions. Even though, the steam distillation is considered as conventional method, but this technique still relevant and preferred in industrial and research area due to several factors i.e. system cost, cleanliness, productivity and operational cost [9]. Moreover, it has several advantages over other methods [10]. In normal operating system, most of steam distillation processes are lacking of system robustness towards parameters changes. A typical controller applied for steam distillation system is ON-OFF controller. It posses disadvantage of being insensitive to parameters changes and exhibits less precision in terms of control response. Moreover, the characteristic of steam temperature is highly nonlinear with uncertainties making the robust controller becomes nontrivial. In order to overcome these shortcomings, a robust hybrid fuzzy-PD plus PID (HFPP) controller that is integrated to steam distillation system is proposed. This controller is expected to execute a robust and better control of steam temperature during distillation process for achieving better assurance of essential oil quality.

There has been a tremendous numbers of research works on fuzzy logic controller associated with Proportional, Integral and Derivative controller components and its applications [11-15]. For thermal or temperature control, [16-19] demonstrated that mixing the fuzzy with P,I and D parts in the controller gained better and effective performance which improved the system response and uncertainties. Additionally, the design of fuzzy itself is based on user experience and knowledge that can offer the user to meet specific system characteristics. The control tuning is the next issue [20,21] that is very important to achieve optimal parameters for fuzzy P-I-D control structure and better system performance and stability. In [12] the fuzzy-PI is more practical but has poor response at transient stage and fuzzy-PD is difficult to reduce steady state error. Therefore the enhancement of fuzzy PID is expected to gain better performance.

The remaining parts of the paper are outlined as follows. Section 2 describes overall system integration in terms of experimental set up and data acquisition. Modeling strategy using generated PRBS as input signal is explained in Section 3. The detail of controller design is elaborated in Section 4. Section 5 will be discussing the results and compares the

control performance of HFPP controller with PID controller.

II. SYSTEM INTEGRATION

A. System Configuration

This section explains the proposed steam temperature control system integration for steam distillation extraction essential oil process. The system is divided into 3 main parts i.e. process plant, data acquisition via PCI-1711 and computer control section as illustrates in Fig. 1. The system consists of a three phase 240-Vac immersion type heater with a power rating of 3kW, microprocessor based 25A ac power controller to drive the heater and temperature sensing modules. The sensor is a platinum sensing element i.e. PT100 3-wires type and connected with signal processing circuit with output ranging from 0 to 5V that corresponds to temperatures from 0°C to 110°C..

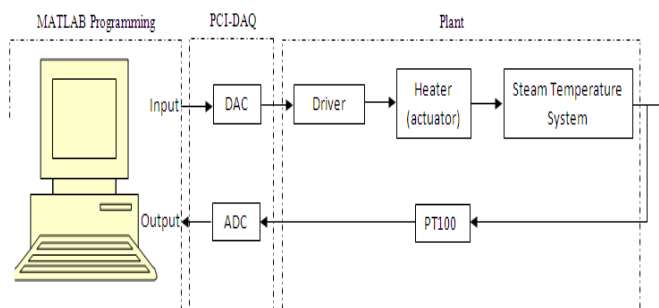

Fig. 1 Block diagram of the overall system integration

The system is using PC-based as control unit. Whereas, acquiring data employed PCI-1711 Advantech data acquisition card to interface between hardware and the computer. MATLAB is a programming tool for control platform and monitoring of signal responses in to or out from the system. The temperature of the plant is regulate using power controller that generates control signals from 0 to 5Vdc via digital-to-analog converter (DAC) then fed to the heater as an actuator to the plant. The sampling period for the system is 10 seconds. For the software part, MATLAB Real Time Workshop (RTW) is employed. The input or perturbed signal is generated from the software.

B. Laboratory Scale Steam Distillation Column

Steam distillation process set up is visualized as in Figure 2(a). The distillation column with 10-litre water has a packed bed that contained botanical material at the top. The water is heated by immersion heater will produce steam which passes through the plant materials. Heat from the steam forces plant's tiny oil sacks to release their preserved essential oil. Then, steam works as a transportation medium for the particles essence to evaporate and condensed. Finally, the yield is in a form of layer of essential oil and hydrosol (mixture of extracted oil and water).

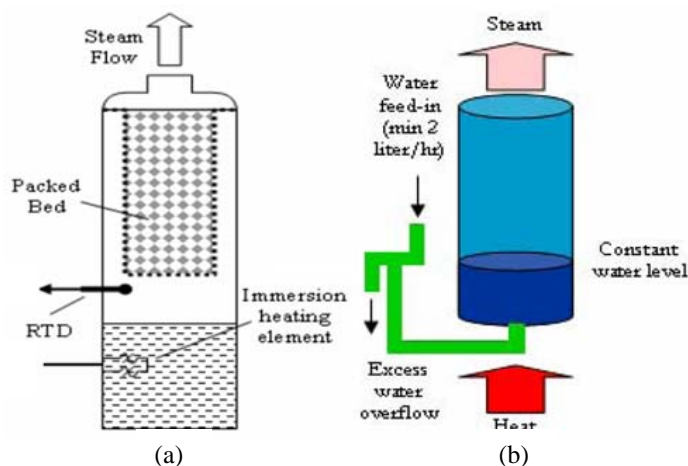

Fig. 2 (a) Plant set up, (b) Water level retaining technique for steam distillation essential oil extraction process

In distillation column, water was maintained at a safety level. There was a self-refilling water line that allowed in-flow water to compensate those evaporated/escaped water in the column. In order to re-utilize water source, the self-refilled water was initially used as coolant for condenser before entering distillation column. The self-refilled water then gets warmer. Consequently, the difference of water temperature flow-in and inside the column can be reduced and thus minimized column temperature disturbance. Figure 2(b) shows a modified steam distillation process [22].

III. MODELING STRATEGY OF STEAM TEMPERATURE RESPONSE

Due to lacking of information on mass transfer, equilibrium relationship together with nonlinear interaction and uncertain conditions in the system, the empirical model is sufficiently enough to represent the system via proper experimentation of steam distillation process. For system characteristics determination, the system is tested using step response with open loop control. The experimental input-output data is acquired by implementation of PCI-1711 Advantech module. A step input signal of $u(t)=5V$ is given to act as control signal and drive the heater response. The process is a quite slow process with time constant of 360s.

Then, for modeling the output temperature response, a Pseudo Random Binary Sequence (PRBS) is perturbed into system input. The use of PRBS is for triggering output response at various frequencies and is an appropriate means to drive the system since it is a periodic signal, deterministic and also similar to white noise properties. In the study, the PRBS signal is generated by 9-bit shift register with an Exclusive OR gate as shown in Fig. 3. The signal is devised as a perturbation signal $u(k)$ for the system. The PRBS amplitude is selected to adhere at maximum of 80% from the full scale (4V) when the PRBS signal is 1 and 20% of full scale (1V)

when the PRBS signal is at 0.

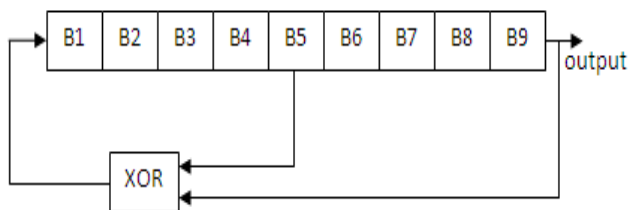

Fig. 3 A 9-bit PRBS signal generation using shift register

Based on the PRBS triggering, the output response of steam temperature output is visualized in Fig. 4. As the water boiled at approximately 77°C of steam temperature, the water gets enough heat energy to convert itself from liquid state to gaseous or steam. The steam produces rigorously and starts to fluctuate and shows a nonlinear behavior. At 1700s, the temperature experience sudden falls at minimum of 72.3°C. The highest value of steam temperature was recorded at 89.3°C approximate at 3580s.

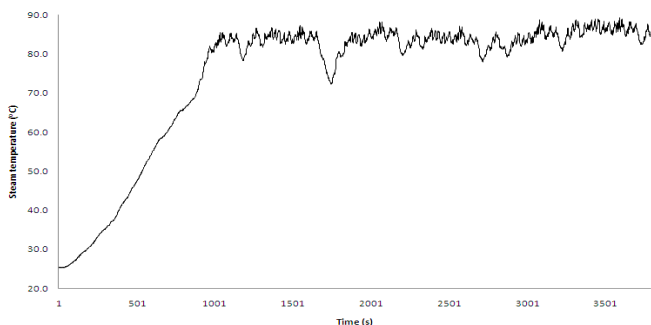

Fig. 4 Steam temperature response using PRBS input signal

A. ARX Modeling

Based on data acquired as in Fig. 4, the steam temperature is represented as $y(t)$. $u(t)$ is referred to PRBS control signal. The steam temperature for steam distillation process can be well approximated by the following autoregressive with exogenous (ARX) model:

$$y(t) = q^{-nk} \frac{B(q)}{A(q)} u(t) + \frac{1}{A(q)} e(t) \quad (1)$$

where $A(q)$ and $B(q)$ are polynomials for output, $y(t)$ and input, $u(t)$ terms. While, $e(t)$ represents white noise entering the system. n is the time delay in the number of sampling time. The chosen sampling time is 10s.

$$\begin{aligned} A(q) &= 1 + a_1 q^{-1} + \dots + a_{na} q^{-na} \\ B(q) &= b_o + b_1 q^{-1} + \dots + b_{nb} q^{-nb} \end{aligned} \quad (2)$$

The modeling data is divided into two parts and subjected for training and validating the model. The division of input-output data is carried out by using interlacing technique; where odd sequence data meant for training while even sequence data is meant for testing or validating purposes. The ARX model obtained from this system identification as

follows:

$$\begin{aligned} A(q) &= 1 - 0.9981 q^{-1} \\ B(q) &= 0.08088 q^{-1} \end{aligned} \quad (3)$$

The validation on testing data of the above ARX model shows the performance criteria using root means squared error (RMSE) is 0.3266. The model accepted to performed simulation for controller design.

IV. HYBRID FUZZY-PD PLUS PID CONTROLLER DESIGN

The hybrid fuzzy-PD plus PID controller is a combination of fuzzy-PD controller with basic PID controller structure in order to improvised the performance of the system under control. Without the present of control scheme, the steam temperature response is originally very dynamic and uncertain therefore smoother output is required for temperature regulation. Fig. 6 illustrates the block diagram of HFPP as a controller module which gives a control signal to power up the heater for distillation column. For measuring system robustness, external disturbance is added.

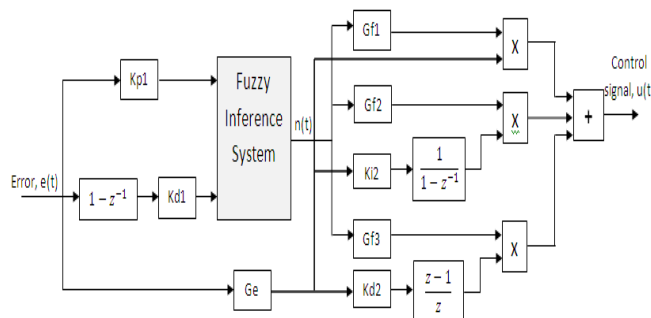

Fig. 5 Structure of hybrid Fuzzy-PD plus PID (HFPP) controller

There are eight gain parameters consist in the HFPP as shown in Fig. 5. $Kp1$, $Kd1$, $Gf1$, $Gf2$ and $Gf3$ are fuzzy-PD gains, whereas, Ge , $Ki2$ and $Kd2$ are PID gains. Tuning these parameters is necessary but before attempting the online application, simulation work has to be established in order to guarantee the system stability and get a hypothetical idea of online output response.

The algorithm of HFPP is stated as in equation (5). The control signal, u is calculated based on summation of all products from fuzzy components and PID components. Whereas n signal is derived from fuzzy operation, $F\{\}$, that consist of two inputs from error and differential error as in (4). The advantage of HFPP is that the output from fuzzy, n can have better fine tune of desired output as the presence of PID. If error occurred, the double controller (Fuzzy-PD and PID) is forced the response to minimize the error signal. If error is zero the controller setting will maintained at present condition.

$$n = F\{kp_1 e, Kd_1 \dot{e}\} \quad (4)$$

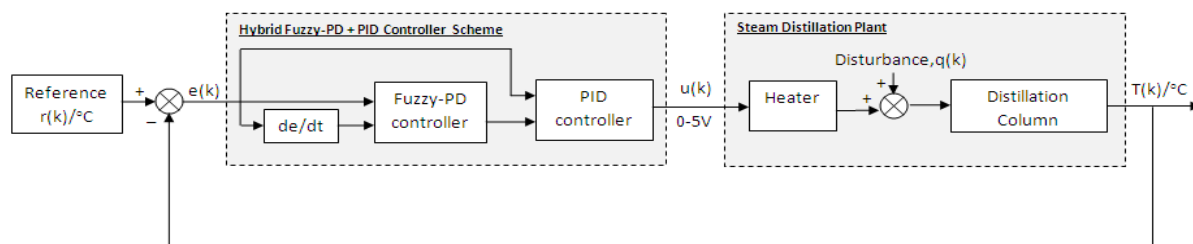

Fig. 6 Diagram of hybrid Fuzzy-PD plus PID controller for steam distillation plant

V. REAL TIME IMPLEMENTATION

$$u = ((Gf_1.n) \times (Ge.e)) + \left((Gf_2.n) \times [Ge.Ki_2 \int_0^{\tau} e(\sigma)d(\sigma)] \right) + ((Gf_3.n) \times (Ge.Kd_2.\dot{e}(\tau))) \quad (5)$$

In order to have a precise control of steam temperature, 49 rules base fuzzy is employed and constructed from 7 conditions of membership function for input error and differential error. The study is also executed based on 25 fuzzy rules to compare with 49 fuzzy rules of HFPP controller.

A. Parameter Tuning

Tuning of HFPP can be performed by adjusting fuzzy rules, membership function or gain parameters. However, tuning of fuzzy rules and membership function makes the task difficult but not really gives much affect to the response if compared to tuning parameters gains [14]. Therefore, as the controller structure is established, the simulation is carried out based on model estimation. Since this system is a slow process, the output response is supposedly to execute with no overshoot, considerably reduce of rise time with minimize steady state error. The fluctuation of temperature response at transient and steady state needs to eliminate especially during higher temperature (above boiling point) where the response is highly dynamic and uncertain behavior. Table I is a list of tuned parameter gains for HFPP.

TABLE I
 HFPP CONTROLLER PARAMETER VALUES

HFPP Parameters	Gains
Kp1	1.0
Kd1	-1.0
Ge	10.0
Ki2	0.4
Kd2	2.0
Gf1	0.1
Gf2	0.1
Gf3	1.0

The aim of the proposed HFPP controller is to provide smooth control for steam temperature and also robust to changes of operation condition during extraction process. The tuned structure of HFPP by the simulation is tested on the real system. However, the selection of fuzzy rules is also important to achieve smoother response and less oscillation at the steady state. Fig. 7 shows the HFPP with 49 rules demonstrates stable response compared to 25 rules. That means the control signal from 49 fuzzy rules of HFPP is more precise and sensitive to the error in correcting the output response.

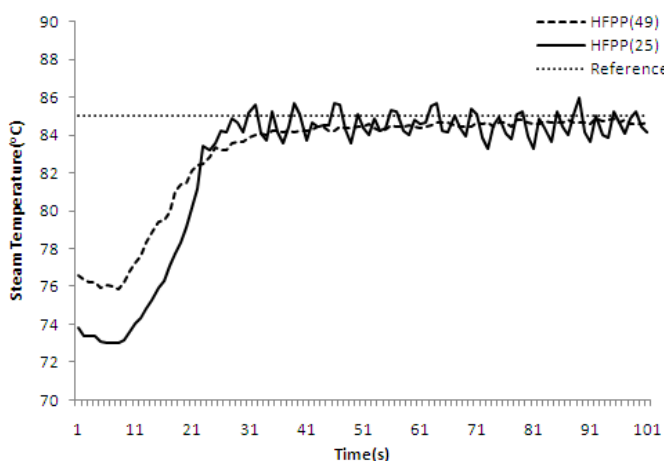

Fig. 7 Steam temperature response for HFPP using 25 and 49 fuzzy rules

A. Robustness test and comparison

The second experiment is conducted to test the ability of controller in compromising an abrupt disturbance during running process. The disturbance added is a water flow-in as a cooling agent that agitated the steam temperature in the column during process run. At the beginning of experiment, a constant of water flow-in is supplied at 0.03 l/min. Starts from 93th sample, an abrupt increase of water flow is applied at 0.06 l/min. The robustness of controller is examined where HFPP performance is still manage to maintained within acceptable temperature range. On the other hand, PID controller is unfortunately executed a spike (2.5°C above set

point) at 96s and showed approximately $\pm 1^\circ\text{C}$ fluctuation of output at its transient stage which is unacceptable. Even though the disturbance is applied, the steam temperature response is smoothly and steadily controlled by robust HFPP throughout the processing period.

temperature that uncertain and very dynamics when it changes to higher degree. These results proved that the proposed controller works well under tested conditions i.e. set point tracking and disturbance rejection.

VI. CONCLUSION

The proposed hybrid fuzzy-PD plus PID controller has been developed for steam distillation of essential oil extraction process. The aim of the study is to test the HFPP robustness in controlling the steam temperature is proved. The performance of proposed controller reveals that under set point changes or disturbance, HFPP is demonstrated the robust response. Due to system dynamics, nonlinear behavior with uncertainties, the online optimization of HFPP parameters is necessary to implement and will be considered as a future improvement.

ACKNOWLEDGMENT

The authors wish to thank FKE UiTM Shah Alam, RMI UiTM and MOSTI for granted Sciencefund SF0226.

REFERENCES

- [1] F. Sefidkon, K. Abbasi, Z. Jamzad, and S. Ahmadi, "The effect of distillation methods and stage of plant growth on the essential oil content and composition of *Satureja rechingeri* Jamzad," *Food Chemistry*, vol. 100, pp. 1054-1058, 2007.
- [2] E. Stashenko, B. Jaramillo, and J. Martínez, "Comparison of different extraction methods for the analysis of volatile secondary metabolites of *Lippia alba* (Mill.) NE Brown, grown in Colombia, and evaluation of its in vitro antioxidant activity," *Journal of Chromatography A*, vol. 1025, pp. 93-103, 2004.
- [3] S. Scalia, L. Giuffreda, and P. Pallado, "Analytical and preparative supercritical fluid extraction of chamomile flowers and its comparison with conventional methods," *Journal of pharmaceutical and biomedical analysis*, vol. 21, pp. 549-558, 1999.
- [4] P. Richter, B. Sepulveda, R. Oliva, K. Calderon, and R. Seguel, "Screening and determination of pesticides in soil using continuous subcritical water extraction and gas chromatography-mass spectrometry," *Journal of Chromatography A*, vol. 994, pp. 169-177, 2003.
- [5] M. Ozel, "Subcritical water extraction of essential oils from *Thymbra spicata*," *Food Chemistry*, vol. 82, pp. 381-386, 2003.
- [6] V. Louli, G. Folas, E. Voutsas, and K. Magoulas, "Extraction of parsley seed oil by supercritical CO₂," *The Journal of Supercritical Fluids*, vol. 30, pp. 163-174, 2004.
- [7] X. Li, S. Tian, Z. Pang, J. Shi, Z. Feng, and Y. Zhang, "Extraction of *Cuminum cyminum* essential oil by combination technology of organic solvent with low boiling point and steam distillation," *Food Chemistry*, vol. 115, pp. 1114-1119, 2009.
- [8] M. Ozel and H. Kaymaz, "Superheated water extraction, steam distillation and Soxhlet extraction of essential oils of *Origanum onites*," *Analytical and bioanalytical chemistry*, vol. 379, pp. 1127-1133, 2004.
- [9] P. Masango, "Cleaner production of essential oils by steam distillation," *Journal of Cleaner Production*, vol. 13, pp. 833-839, 2005.
- [10] A. Ammann, D. Hinz, R. Addleman, C. Wai, and B. Wenclawiak, "Superheated water extraction, steam distillation and SFE of peppermint oil," *Fresenius' Journal of Analytical Chemistry*, vol. 364, pp. 650-653, 1999.
- [11] J. Lee, "On methods for improving performance of PI-type fuzzy logic controllers," *IEEE Transactions on Fuzzy Systems*, vol. 1, 1993.
- [12] H. Li and H. Gatland, "Conventional fuzzy control and its enhancement," *IEEE Transactions on Systems, Man, and Cybernetics, Part B: Cybernetics*, vol. 26, pp. 791-797, 1996.
- [13] L. Reznik, O. Ghanayem, and A. Bourmistrov, "PID plus fuzzy controller structures as a design base for industrial applications,"

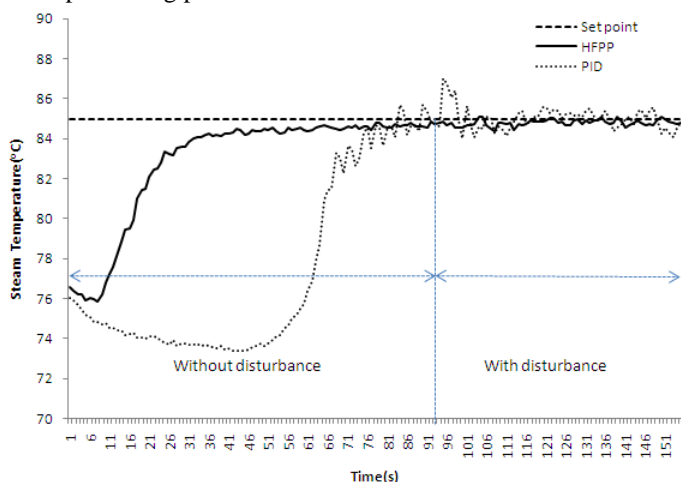

Fig. 8 Steam temperature response for HFPP (49 fuzzy rules) with water flow disturbance comparing with PID controller

The HFPP controller is also assessed on its capability of tracking the set point, $r(k)$ as follows:

$$r(k) = \begin{cases} 79^\circ\text{C}; & 1 < k < 65 \\ 85^\circ\text{C}; & 66 < k < 165 \\ 82^\circ\text{C}; & 166 < k < 265 \\ 79^\circ\text{C}; & 266 < k < 365 \end{cases}$$

Practically, both HFPP and PID controllers have to force output response to follow the set point by minimizing the error between reference and actual signals. As can be seen in Fig. 9, at lower temperature level, both controllers performed well in tracking the stipulated set point.

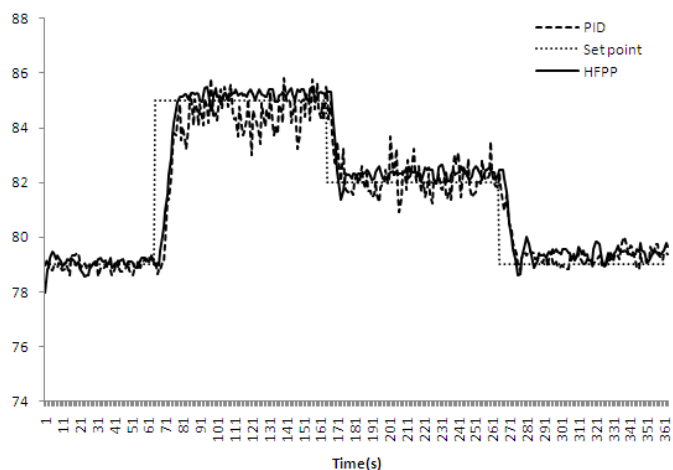

Fig. 9 Performance of HFPP controller with set point tracking compared to PID controller

Regardless of high temperature, HFPP still showed a consistent and better control performance compared to PID. PID is inconsistent due to difficulty of controlling the steam

- Engineering Applications of Artificial Intelligence*, vol. 13, pp. 419-430, 2000.
- [14] Y. Zhao and E. Collins Jr, "Fuzzy PI control design for an industrial weigh belt feeder," *IEEE Transactions on Fuzzy Systems*, vol. 11, p. 311, 2003.
- [15] Q. Yang, G. Li, and X. Kang, "Application of fuzzy PID control in the heating system," 2008, pp. 2686-2690.
- [16] S. Mansour, G. Kember, R. Dubay, and B. Robertson, "Online optimization of fuzzy-PID control of a thermal process," *ISA transactions*, vol. 44, pp. 305-314, 2005.
- [17] T. Blanchett, G. Kember, and R. Dubay, "PID gain scheduling using fuzzy logic," *ISA transactions*, vol. 39, pp. 317-325, 2000.
- [18] A. Sanchez-Lopez, G. Arroyo-Figueroa, and A. Villavicencio-Ramirez, "Advanced control algorithms for steam temperature regulation of thermal power plants," *International Journal of Electrical Power & Energy Systems*, vol. 26, pp. 779-785, 2004.
- [19] I. Škrjanc and D. Matko, "Predictive functional control based on fuzzy model for heat-exchanger pilot plant," *IEEE Trans. Fuzzy Syst*, vol. 8, pp. 705-712, 2000.
- [20] Q. Xiang, H. Xie, H. Henderson, A. Kay, M. Fontes, S. Weed, X. Jian-Xin, L. Chen, and C. Chang, "Tuning of fuzzy PI controllers based on gain/phase margin specifications and ITAE index," *ISA transactions*, vol. 35, pp. 79-91, 1996.
- [21] A. Visioli, "Tuning of PID controllers with fuzzy logic," *IEE Proceedings-Control Theory and Applications*, vol. 148, pp. 1-8, 2001.
- [22] M. H. F. Rahiman, M. N. Taib, and Y. M. Salleh, "Assessment of NNARX structure as a global model for self-refilling steam distillation essential oil extraction system," in *International Symposium on Information Technology (ITSim)* pp. 1-7, 2008.