

Modeling and Performance Evaluation of LTE Networks with Different TCP Variants

Ghassan A. Abed, Mahamod Ismail, and Kasmiran Jumari

Abstract—Long Term Evolution (LTE) is a 4G wireless broadband technology developed by the Third Generation Partnership Project (3GPP) release 8, and it's represent the competitiveness of Universal Mobile Telecommunications System (UMTS) for the next 10 years and beyond. The concepts for LTE systems have been introduced in 3GPP release 8, with objective of high-data-rate, low-latency and packet-optimized radio access technology. In this paper, performance of different TCP variants during LTE network investigated. The performance of TCP over LTE is affected mostly by the links of the wired network and total bandwidth available at the serving base station. This paper describes an NS-2 based simulation analysis of TCP-Vegas, TCP-Tahoe, TCP-Reno, TCP-Newreno, TCP-SACK, and TCP-FACK, with full modeling of all traffics of LTE system. The Evaluation of the network performance with all TCP variants is mainly based on throughput, average delay and lost packet. The analysis of TCP performance over LTE ensures that all TCP's have a similar throughput and the best performance return to TCP-Vegas than other variants.

Keywords—LTE; EUTRAN; 3GPPP,SAE; TCP Variants; NS-2

I. INTRODUCTION

NEXT-Generation and new wireless technologies such as WiMax and LTE, provide very high rates of data of several Mbps to mobile users. Then, the mobile users will come to expect better peak performance from the networks than from current mobile networks. LTE is intended to be a mobile-communication system that can take the telecom industry into the 2020's. The core network is focused on the packet-switched domain, migrating away from the circuit-switched network. LTE will provide significantly increased peak data rates, with the potential for 100 Mbps downstream and 30 Mbps upstream, reduced latency, scalable bandwidth capacity, and backwards compatibility with existing GSM and UMTS technology. The System Architecture Evolution (SAE) core network architecture significantly enhances the core network performance while ensuring interoperability with previous networks such as High Speed Packet Access (HSPA). Hence LTE will be very convincing for network operators that already have HSPA networks running [1]. LTE standard was first published in March of 2009 as part of the 3GPP specifications.

Comparing the performance of 3G and its evolution to LTE, LTE does not offer anything unique to improve spectral efficiency, i.e. bps/Hz. LTE improves system performance by using wider bandwidths if the spectrum is available [2]. Universal Terrestrial Radio Access Network Long-Term Evolution (UTRAN LTE), also known as Evolved UTRAN (EUTRAN) is a new radio access technology proposed by the 3GPP to provide a very smooth migration towards fourth generation (4G) network [3]. EUTRAN is a system currently under development within 3GPP. LTE systems is under developments now, and the TCP protocol is the most widely used protocol for wired and wireless systems, although TCP was not originally designed for real time applications and not for wireless networks then, we need to develop a new TCP mechanisms, or at least choose a suitable TCP variant for each new network, to be more efficient and more reliability with this network. In this paper, we assumed to test six variants of TCP, in other word, the all source variants, Tahoe, Reno, Newreno, Sack, Fack, and Vegas. The main goal is to evaluate the behavior of these six variants over a fully LTE model using one of the better network simulators, NS-2 [4]. As we will explain later in this paper, we modulated all LTE links and traffics in one complete simulation and supported it by six types of TCP, one by one, and monitoring the result of evaluation through traces of throughput, lost packet, and the delay through the data streaming. Before we start to illustrate the architecture of LTE networks, in the next section, we need to know the main five parts of any LTE network. As shown in Fig. 1, it consists from: evolved-NodeB (eNodeB), Serving Gateway, Packet Data Gateway, User Equipment, and Routing Unit. The rest of this paper is organized as follows. Section II describes the details of LTE network architecture with main parameters and requirements. TCP over LTE networks will discuss and comment in section III. The simulation and LTE modeling will presents in Section IV. The performance evaluation and analysis will explain in Section V. The Last Section VI concludes the paper.

II. LTE NETWORK ARCHITECTURE

Developed by 3GPP, LTE is the leading Orthogonal Frequency-Division Multiple Access (OFDMA) wireless mobile broadband technology. LTE offers high spectral efficiency, low latency and high peak data rates. LTE leverages the economies of scale of 3G, as well as the ecosystem of infrastructure and devices vendors to provide the highest performance in a cost effective manner [2].

All Authors, Department of Electrical, Electronic & Systems Engineering - Faculty of Engineering & Built Environment, National University of Malaysia, UKM, (E-mail: ghassan | mahamod | kbj @eng.ukm.my)

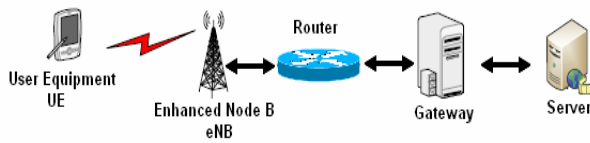

Fig. 1 General Representation of LTE System

The notion of LTE technology depends on the understood that it improves system performance in terms of data rate, throughput, latency, coverage and cost. LTE offers a pure packets assigned architecture, with viability of the movement management. The latest step being studied and developed in 3GPP is an evolution of 3G into an evolved radio access referred to as the LTE and an evolved packet access core network in the System Architecture Evolution (SAE) [5]. In this section, architecture for LTE/SAE introduced. So, the architecture which is considered for 3GPP is shown in Fig. 2. E-UTRAN architecture based on, eNB-1, eNB-2, and eNB-3 acts as a base station, and called E-UTRAN Node B. MME represents the Mobility Management Entity. S-GW is a serving gateway, and last, P-GW is a PDN (Packet Data Network) Gateway. Each eNB are connected to the MME/SAE Gateway by the S1 interface where as X2 interface is interconnecting the eNBs. The X2 interface is used also on U-plane for temporary user downlink data. The main functions of the eNB are: (1) radio resource management (radio bearer control, radio admission and connection mobility control, dynamic scheduling) and (2) routing user plane data towards SAE Gateway. The main task of MME/SAE Gateway is to distribute the migration of messages to eNBs; security control; encryption of user data, switching of U-plane to support of UE mobility; idle mode mobility handling [6]. Fig. 3 shows the interface protocol stacks of S1 and X2. We used the same block diagram for two interfaces because it is similar, where the term (S1, X2 - AP) means that (S1-AP) or (X2-AP). The S1 user plane interface (S1-U) is defined between the eNB and the S-GW. The S1-U interface uses GTP-U (GPRS Tunneling Protocol-User Data Tunneling) on UDP/IP transport and provides non-guaranteed delivery of user plane PDUs between the eNB and the S-GW.

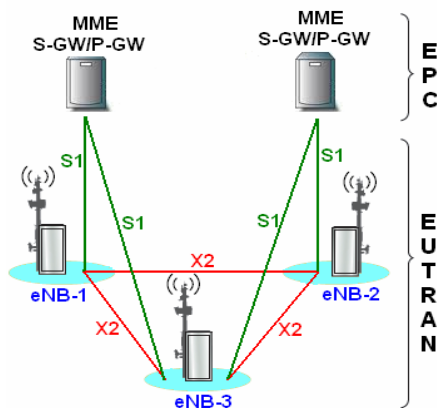

Fig. 2 E-UTRAN and EPC Architecture

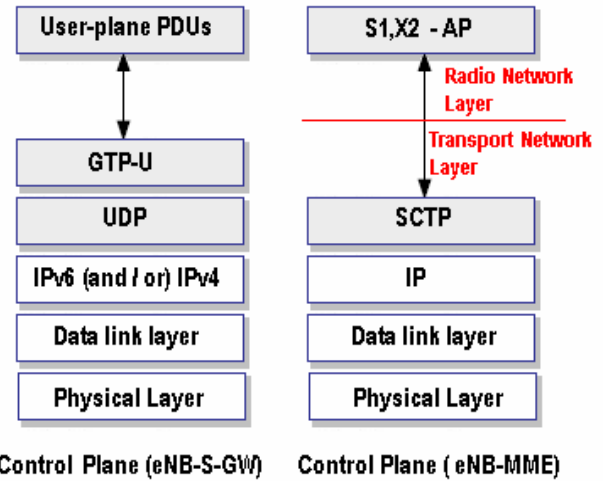

Fig. 3 (S1 and X2) Interface User and Control Planes

The S1 control plane interface (S1-MME) is defined as being between the eNB and the MME. Similar to the user plane, the transport network layer is built on IP transport and for the reliable transport of signaling messages SCTP (Stream Control Transmission Protocol) is used on top of IP. The SCTP protocol operates analogously to TCP ensuring reliable, in-sequence transport of messages with congestion control. The application layer signaling protocols are referred to as S1 application protocol (S1-AP) and X2 application protocol (X2-AP) for S1 and X2 interface control planes respectively [7]. The main other part of LTE/SAE architecture, represented by EPC (Evolved Packet Core). The term "LTE" encompasses the evolution of the (UMTS) radio access through the Evolved UTRAN (E-UTRAN), it is accompanied by an evolution of the non-radio aspects under the term "System Architecture Evolution" (SAE), which includes the Evolved Packet Core (EPC) network. The E-UTRAN and EPC together set up and release bearers as required by applications. The basic three nodes of the EPC are: PDN Gateway (P-GW), Serving Gateway (S-GW), Mobility Management Entity (MME), and this permit to EPC to be the core of network (called EPC in SAE) and it is responsible for the overall control of the UE. LTE, 3GPP is also defining IP-based, flat network architecture. This architecture is defined as part of the (SAE) effort. The LTE/SAE architecture and concepts have been designed for efficient support of mass-market usage of any IP-based service.

III. TCP OVER LTE SYSTEMS

TCP is designed in early days of ARPANET specifically for wired networks, shows poor performance over wireless channels, mainly due to high error rates [8]. In order to compensate wireless errors, LTE employs error recovery techniques at the link layer, which partially overlap with error recovery performed at the transport layer of TCP/IP. LTE assumes that the end-to-end TCP governs the congestion control and adapts to the varying network conditions and handle packet loss [9]. In addition, LTE systems are support a good concept of QoS (Quality of Service) on radio and

transport network, in other hand, no flow control mechanisms are supported, and this will cause some dropping in packet while congestion period at any terminal or node. So, we know that each variant of TCP, have a private behavior in congestion period, then we need to monitor each variant and analysis the performance through LTE system to choose – develop or modify- the best TCP that will be more efficient over LTE system. It's very natural that we will find some shortcomings in the performance of the TCP, in particular by deciding BER (Bit Error Rate) and the Handover availability, but at this stage we will try to find out and determine the best performance to be submitted by any kind of the six TCP variants in this paper, these six variants, called the source variants of TCP, and may be in next research we will deal with other new variants, and see the behavior and the performance of each TCP over LTE network topology. However, development of TCP over LTE, or any other network with large bandwidth, and delay variation, with high rate of packets lost, will remain the main challenge. TCP over LTE is expected to improve substantially end-user throughput, cell capacity, and transmission latency. Given the popularity of the Transmission Control Protocol TCP, and Internet Protocol (IP) for carrying all types of traffic, LTE supports TCP and IP-based traffic with end-to-end quality of service [10]. There are many parameters to evaluate TCP performance in any network topology, such as, effective throughput, throughput variation, file transfer time, round trip time (RTT), delay variation, fairness, buffer space, and transmission power, so, in our evaluation we will choose three metrics, one of them is the effective bandwidth. This metric of performance evaluation depends on the rate of data transmission over the application in bps, which is more significant than the communication channel throughput, since it takes into account the effective amount of data delivered at the TCP layer. In this research, we have tested the performance of six variants of TCP, under various network conditions, and the performance was measured in average throughput, average performance convergence time, as well as application layer latency.

IV. MODELING AND SIMULATION

We evaluated performance of the proposed model by using an extension of the NS-2 simulator. Before describing the model requirements and configuration, and because we used the network simulator, NS-2, we must explain, NS-2 is a discrete event simulator targeted at networking research. NS-2 provides substantial support for simulation of TCP, routing, and multicast protocols over wired and wireless (local and satellite) networks [4].

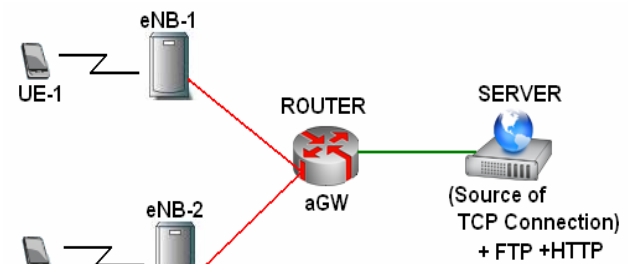

Fig. 4 Proposed Topology

In NS-2 simulation, all the data in the network is available, thus the performance of the network can be easily analyzed. NS-2 is free and open source code and suitable to build system level simulation, so it is deployed to simulate LTE/SAE, or any other network. In our research, we used NS-2 version 2.32, and this version, can be installed over Windows Xp or Windows 7 with using Cygwin, where Cygwin provides a Linux-like environment under Windows, because NS-2 already supported a Linux operating system only, then we need to get a virtual environment. Fig. 4, shows the proposed model, for this research, it consists from one server for serving FTP and HTTP, and to provide a source connection for the TCP link over the topology. The router aGW, connected to the server with duplex link (two ways) and DropTail, with bandwidth of 100Mbps, and propagation delay of 2 msec. The main job of aGW router is to control the flow rate of the streaming data from server to eNB-1, and eNB-2, so these two nodes, responsible for buffering the data packets for User Equipments, 1 and 2 respectively. Each eNB, connected to the corresponding aGW through wired simplex link (one way) of 5Mbps bandwidth and 2 msec delay. The other main parameters of proposed LTE topology illustrated in Table I, and we can note that all link kept for one propagation delay of 2msec, and the maximum packet size of TCP was set to 1500 Byte, with minimum window size of 48 Kbytes. The simulation and the requirements of performance evaluation divided in to two parts, one deals with the system modeling animator (represented in nam file) as shown in Fig. 5, and the other parts deals with using the graph ability of NS-2 to analysis and monitoring the behavior of throughput, queue size and packet lost of the proposed topology, and all these results, represented by NS-2 scripts using trace files.

TABLE I
 SIMULATION PARAMETERS

Parameters	Value
Propagation Delay of all links	2 msec
Bandwidth of aGW link	5 Mbps
Bandwidth of Server link	100 Mbps
Packet Size	1500 Byte
Window size	48 KBytes
Simulation Time	30 sec

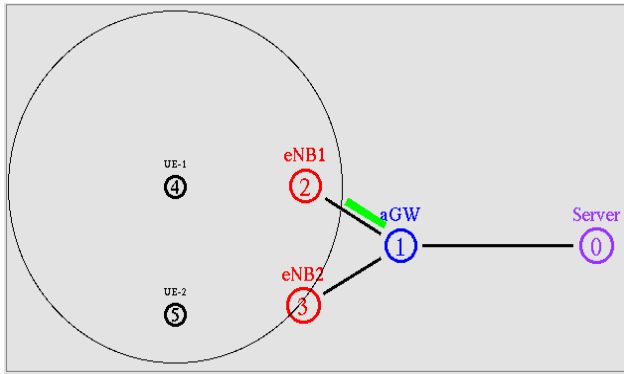

Fig. 5 Real Network Animator (nam) Session

In Fig. 5, the two wireless nodes UE-1. and UE-2, linked to the corresponding eNB, through wireless link as a mobile nodes, but really the two nodes not have full mobility features, because they not move yet, and if we support the movement of these nodes we must add a Handover scenario to the topology, and this is not our goal in this research, so for that we ignored the interface between eNB-1 and eNB-2. In evaluation of TCP throughput performance on wireless cellular networks, it is necessary to consider the effect of packet losses and transmission errors on the radio link on the TCP performance, which is the main subject of this paper. We evaluated the TCP performance by explicitly modeling the performance characteristics of the underlying data link layer protocol.

V. PERFORMANCE EVALUATION AND ANALYSIS

The evaluation of the network performance is mainly based on the three main criteria, throughput, queue size, and packet losses, when the throughput can represents as:

$$\text{Throughput (bits/s)} = (\text{Number of delivered packets} * \text{size of packets} * 8) / \text{Total duration of simulation.}$$

Throughput is the total amount of data exchanged per second between a source and destination in the network, and defined as a sum of sizes of all received packets divided by the duration of the simulation. The throughput is a function of various parameters such as queue size, window size, amount of error on the link, maximum segment size and round trip

delay. So, we can add another main metric, called delivery ratio, where:

$$\text{Delivery Ratio} = \text{Number of delivered packets} / \text{Total number of transmitted Packets.}$$

The packet loss defined as the probability of a new packet arrives when the queue is full versus time, and it's a main measure of the amount of effective performance of data streaming from sender to receiver in any topology. Here, in this paper as we mentioned, throughput, queue size, number of packet losses per time unite, measured for Tahoe, Reno, Newreno, Sack, Fack, and Vegas TCP, over a model of LTE network. Fig. 6 indicates the queue size of data streaming, and as illustrated, we can see that when window size decreases, the performance of TCP's will be better and almost same when window size is default. Fig. 6 shows that Vegas is more efficient then other TCP variants and gives more throughputs. From observation of the previous figure, the queue size stabilizes at 3000, this is the maximum queue size that is reached, and from this moment on there will be losses at the queue. In lost packets graph, which shown in Fig. 7 , it is apparent from the results that Sack-TCP not exceeds 8000 packets, while all other variants ranged between 20000-30000 packets, and to be exact, Sack and Vegas have the lowest packets losses, while Fack have the highest. However it can be observed that TCP-Vegas perform well with our model then other variants, and this decision come form notes the behavior of Vegas-TCP, where it have a small queue delay compared with other, with lowest packets losses, in addition to stable bandwidth throughput. Fig. 8, represents the results of performance of the six TCP's, and it's easy to notes the throughput traces, and how it's have the same behavior. In general, we found that the difference in throughput between the different TCP variants is less than 10%. So, the most important insight that we obtained have the similar throughput

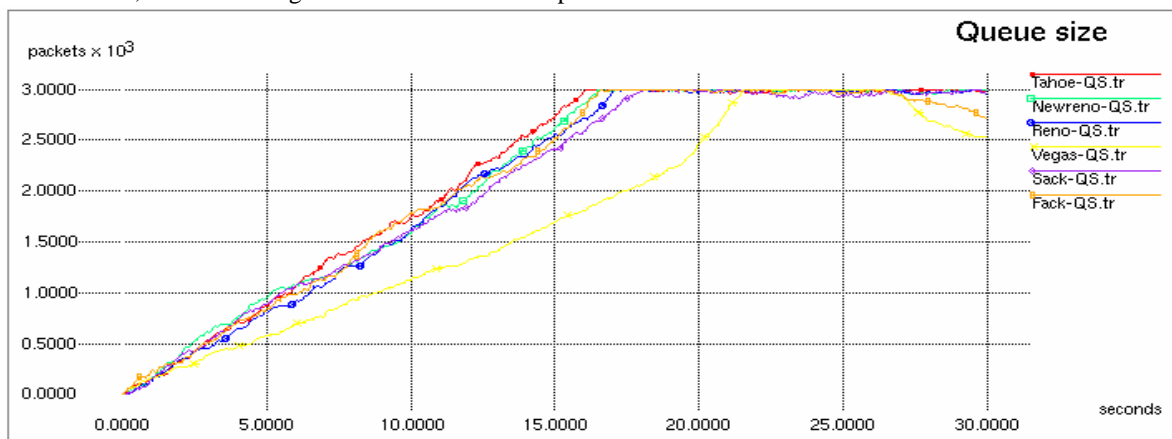

Fig. 6 Comparison Queue sizes versus time of different TCP variants

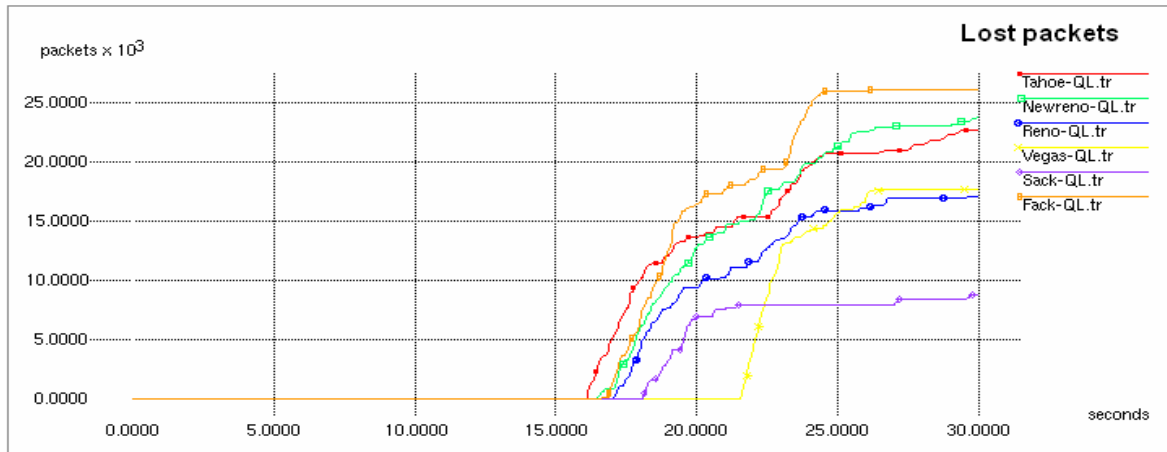

Fig. 7 Comparison Lost Packets versus time of different TCP variants

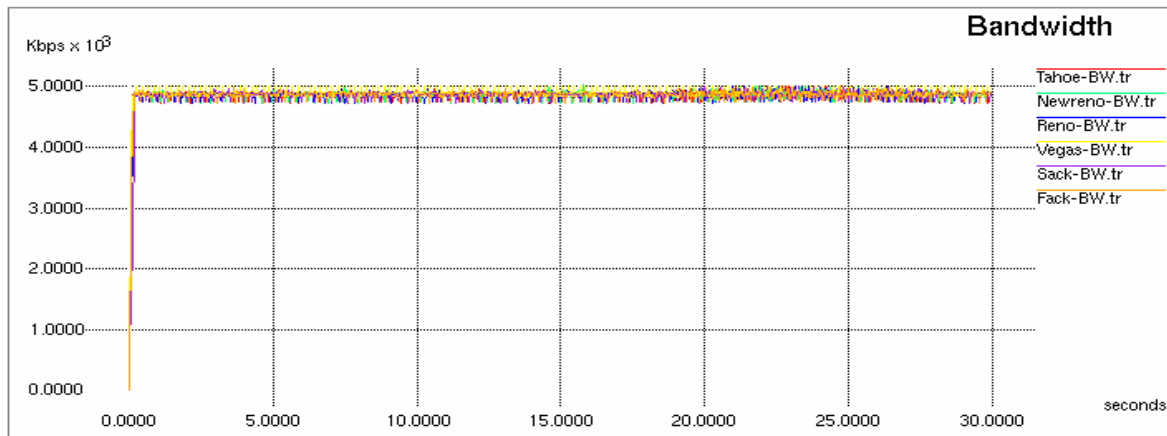

Fig. 8 Comparison Bandwidths versus time of Different TCP variants

Fig. 8 shows the value and the performance level of the TCP's, and it is no doubt it looks close to a large extent the level of performance and efficiency in our proposed model, and this is likely since all the species that have been addressed in this research was not designed to support high-speed networking or to deal with the a high rate of data transferring, in addition, it did not take into consideration the prospects for work in wireless networks and can pass its conditions of interruption, interference, or the BER. So we not found any distinctive to a species from one to the others, and that leads to find a new technique and mechanisms added to those species to make it working in more efficiency rate than what they are now.

VI. CONCLUSION

In this paper, we measured and analyzed the throughput, queue size, and lost packet performance of different versions of TCP over a model of LTE network using NS-2 network

simulator. The main goal of our research is to implement a traffic model of LTE network and try to evaluate and investigate the performance with default network parameters, such as bandwidth, delay, window size, packet size, and queue limit. The complete analysis of TCP performance during LTE simulation, ensure that all TCP's performance a similar throughput and the best performance return to Vegas-TCP, where we got maximum bandwidth and minimum lost packets then other TCP versions. Future work includes an extension of analysis the other new TCP variants, like Snoop, Freeze, Eifel, ESSE, HSTCP, and others over the same LTE model.

REFERENCES

- [1] J. C. Ikuno, M. Wrulich, and M. Rupp, "TCP Performance and modeling of LTE H-ARQ," in proceedings of the *International ITG Workshop on Smart Antennas (WSA 2009)*, Berlin, Germany, 2009.
- [2] A. Khandekar, N. Bhushan, J. Tingfang, and V. Vanghi, "LTE-Advanced: Heterogeneous Networks," in proceeding of *European Wireless Conference*, Italy, 2010.
- [3] C. Lin, K. Sandrasegaran, H. A. Ramli, and M. Xue, "Requirement of Handover Modeling in the Downlink 3GPP Long Term Evolution System," in proceeding of *24th IEEE International Conference on Advanced Information*

Networking and Applications Workshops, Perth, Australia, 20–23 April 2010.

- [4] “NS-2 Network Simulator,” <http://www.isi.edu/nsnam/ns/>, 2000.
- [5] S. Parkvall, E. Dahlman, J. Sköld, and P. Beming, “3G Evolution: HSPA and LTE for Mobile Broadband,” *Elsevier Publishers*, Second Edition, 2008.
- [6] L. Bajzik, P. Horváth, L. Krössy, and C. Vulkán, “Impact of Intra-LTE Handover with Forwarding on the User Connections,” July 2007.
- [7] F. Khan, “LTE for 4G Mobile Broadband: Air Interface Technologies and Performance,” *Cambridge University Press*, New York, 2009.
- [8] D. Kliazovich, F. Granelli, S. Redana and N. Riato, “Cross-Layer Error Control Optimization in 3G LTE,” in proceeding of the *IEEE Global Communications Conference (GLOBECOM)*, Washington D.C., USA, 2007.
- [9] D. Pacifico, M. Pacifico, C. Fischione, H. Hjalmarrsson, and K. H. Johansson, “Improving TCP Performance During the Intra LTE Handover,” in proceeding of *IEEE Globecom, Honolulu, HI, USA, 2009*.
- [10] G. A. Abed, M. Ismail, and K. Jumari, “Behaviour of cwnd for Different TCP source Variants over Parameters of (LTE) Networks,” *Information Technology Journal*, ISSN: 1812-5638, Science Alert, 2010.