

# On the dynamic behaviour of a four-bar linkage driven by a velocity controlled DC motor

Giovanni Incerti

**Abstract**—The dynamic behaviour of a four-bar linkage driven by a velocity controlled DC motor is discussed in the paper. In particular the author presents the results obtained by means of a specifically developed software, which implements the mathematical models of all components of the system (linkage, transmission, electric motor, control devices). The use of this software enables a more efficient design approach, since it allows the designer to check, in a simple and immediate way, the dynamic behaviour of the mechanism, arising from different values of the system parameters.

**Keywords**—Four-bar linkage, Speed control, Dynamic analysis.

## I. INTRODUCTION

AS is well known, the four-bar linkages are widely diffused in the industrial field and the basic theory used for their design is well developed in the technical literature.

In most cases, the functional design of the mechanism requires only a kinematic analysis of the system; a more accurate study, however, must take into account also the dynamic aspects, in order to optimize the behaviour of the mechanism during its operation.

In many industrial applications the four-bar linkages are driven by constant speed motors, but thanks to the increasingly widespread use of servomotors with position and/or speed control, is not uncommon to find applications in which the crank of the mechanism is driven at variable speed.

In cases where special motion laws are required, the driving motor is usually interfaced with a digital controller and a double feedback loop (velocity and position), is implemented, in order to ensure a good performance of the system.

Based on these considerations, it is clear that the dynamic behaviour of a four-bar linkage driven by a servomotor should be analyzed considering the effects arising from the drive and the electric speed regulator: in other words, the motion equation of the mechanical device must be solved simultaneously with the differential equations which describe the electric behaviour of the motor and the dynamics of its control system.

In the technical literature the contributions on this subject are numerous and extend over a wide period. In [1] the speed control of the crank of a four-bar linkage is performed by a PID controller whose parameters are determined by nonlinear optimization techniques. In [2] the authors propose an adaptive controller with experimental validation, which is able to compensate for the nonlinear dynamics of the mechanism.

Other theoretical and experimental contributions can be found in [3], where the authors analyze the dynamics of a four-bar linkage driven by a brushless motor programmed for

the execution of complex motion laws. In [4] a balancing procedure is proposed, in order to improve the performance of the mechanism, under particular working conditions.

The use of the *fuzzy logic* in place of the conventional PID regulation is proposed in [5], in order to control the angular velocity of a motor driving a four-bar linkage.

Other interesting approaches to the integrated mechatronic design of a linkage are available in [6] and [7]: in these works, recently published, the authors adopt advanced optimization methods for the synthesis of mechanisms, so that different design specifications can be simultaneously satisfied.

This paper presents the calculation procedure for analyzing the dynamic behaviour of a four-bar linkage driven by a DC servomotor with velocity feedback; the developed model is implemented in a software that can be used by the designer in order to verify the performance of the mechanism as a function of the geometric, inertial, electrical and control parameters.

## II. MATHEMATICAL MODEL OF THE SYSTEM

To analyze the dynamic behaviour of the mechatronic device under consideration is necessary to use appropriate mathematical models for each of its components: the linkage, the electric motor, the gear-box, and the speed regulator. Finally the obtained differential equations must be simultaneously solved by using a numerical algorithm.

### A. Dynamics of the four-bar linkage

A four-bar linkage is schematically represented in Fig. 1. Link 1 (crank) is driven by a DC motor through a gear transmission and it can perform a complete rotation about the pin A; link 2 (coupler) performs a rototranslatory motion in the  $xy$  plane and it transmits the movement to link 3 (rocker-arm), which executes an oscillatory motion about the pin D. To give more generality to the problem it will be assumed that the mechanism operates in the vertical plane (and therefore under the effect of gravity), the pivot D does not belong to the  $x$  axis and the centers of mass of the rods (respectively indicated by the symbols  $G_1$ ,  $G_2$  e  $G_3$ ) does not belong to the straight lines joining the pivots of the linkage.

The position of the three centers of mass will then be described by the three pairs of polar coordinates  $f_i$  and  $\vartheta_i$  ( $i = 1, 2, 3$ ) visible in Fig. 1.

The lengths of the three links of the mechanism are indicated by the symbols  $a$ ,  $b$ ,  $c$ , while their angular positions with respect to the horizontal axis are indicated by the symbols  $\alpha$ ,  $\beta$  and  $\gamma$  respectively.

The origin of the Cartesian reference system coincides with the crank pin (point A), while the position of the rocker-arm

G. Incerti is with the Department of Mechanical and Industrial Engineering, University of Brescia, 25123, Brescia, Italy. e-mail: giovanni.incerti@ing.unibs.it.

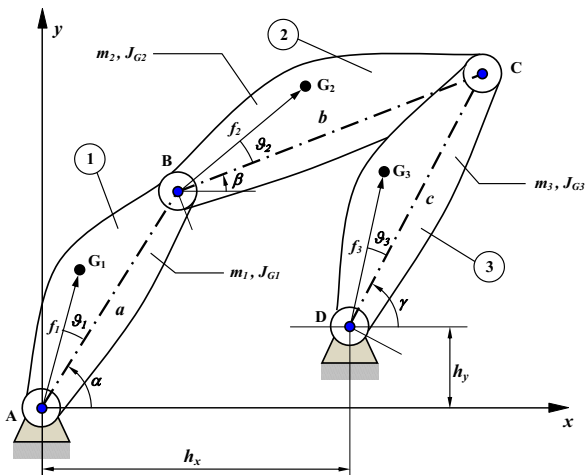

Fig. 1. Schematic of a four-bar linkage.

pivot is defined by the coordinates  $h_x$  and  $h_y$ . The symbols  $m_i$  and  $J_{Gi}$  ( $i = 1, 2, 3$ ) denote respectively the masses and the moments of inertia of the rods about their centers of mass.

The kinematic analysis of the mechanism can be easily carried out in closed form and therefore it does not present particular difficulties; in this way is possible to calculate the position and the velocity of links 2 and 3 as a function of the position and speed of link 1.

To perform the dynamic analysis of the system under consideration we use an energetic approach. Let  $E_k$  and  $E_p$  be respectively the kinetic and potential energy of the four-bar linkage and let  $W$  be the work done by the external non-conservative actions. The work-energy principle for the mechanism can be written in the following form:

$$\frac{d}{dt}(E_k + E_p) = \frac{dW}{dt} \quad (1)$$

The kinetic energy of the mechanism is:

$$E_k = \frac{1}{2}J(\alpha)\dot{\alpha}^2 \quad (2)$$

where  $J(\alpha)$  is an equivalent moment of inertia, whose value varies as function of the crank angle (see the Appendix C for details).

Since the mechanism operates in a vertical plane, its potential gravitational energy  $E_p$  depends on the quotes of the centers of mass of each link, which are a function of the crank angle  $\alpha$ . If we use the symbols of Fig. 1, the potential energy assumes the following form:

$$E_p(\alpha) = g(m_1y_{G1} + m_2y_{G2} + m_3y_{G3}) \quad (3)$$

where  $g$  is the gravitational acceleration, whereas  $y_{G1}$ ,  $y_{G2}$  e  $y_{G3}$  indicate the quotes of the centers of mass, which can be easily calculated through the following relationships:

$$\begin{aligned} y_{G1} &= f_1 \sin(\alpha + \vartheta_1) \\ y_{G2} &= a \sin \alpha + f_2 \sin(\beta + \vartheta_2) \\ y_{G3} &= h_y + f_3 \sin(\gamma + \vartheta_3) \end{aligned} \quad (4)$$

The right-hand side of equation (1) can be expressed as  $dW/dt = T_c\dot{\alpha}$ , where  $T_c$  is the torque acting on the crank of the mechanism.

Substituting in (1) the expressions previously obtained for the kinetic and potential energy, computing their time derivatives and performing the necessary simplifications, we obtain the motion equation of the four-bar linkage, which assumes the following form:

$$\frac{1}{2} \frac{dJ(\alpha)}{d\alpha} \dot{\alpha}^2 + J(\alpha)\ddot{\alpha} + \frac{dE_p(\alpha)}{d\alpha} = T_c \quad (5)$$

### B. The motor and transmission model

Here, we suppose that the linkage is driven by a permanent magnet DC motor by means of a gear speed reducer. If an electronically commutated brushless motor is used, the present discussion is still valid, since also for this kind of motor an equivalent electrical model similar to that of the DC motor can be obtained. Fig. 2 shows in detail the equivalent diagram of the motor-transmission assembly. We denote by  $\dot{\varphi}$  the angular speed of the motor and  $z = \dot{\varphi}/\dot{\alpha}$  the gear ratio. From Fig. 2 it is clear that the angular speed of the output shaft of the transmission coincides with the angular velocity of the crank.

The input variable for the system is the armature voltage  $V_a$ , generated by a power amplifier, while the output variable is the torque  $T_c$  acting on the crank the four-bar linkage.

From the electrical point of view the motor is described by three parameters: the armature resistance  $R$ , the armature inductance  $L$  and the voltage constant  $k_m$  which expresses the ratio between the back electromotive force  $E$  and angular speed of the motor. As it is known, this constant is identical to the torque constant of the motor, when the SI units are used (i.e.  $Vs/rad$  for the voltage constant and  $Nm/A$  for the torque constant). The symbol  $J_m$  indicates the moment of inertia of the motor, whereas the inertias of the gear pair are indicated by the symbols  $J_a$  and  $J_b$  respectively.

In order to consider the frictional effects of the bearings, a resistant torque was added on the motor shaft; its analytical expression is:

$$T_r = T_0 + \lambda\dot{\varphi} \quad (6)$$

where  $T_0$  is a constant term and  $\lambda$  is a proportionality coefficient which must be chosen so as to reproduce in a reliable manner the effects due to the viscous friction of the bearings.

To analyze the electrical behaviour of the DC motor, we apply the Kirchhoff's voltage law to the armature circuit; using the sign conventions of Fig. 2 we obtain:

$$V_a = RI + L \frac{dI}{dt} + k_m\dot{\varphi} \quad (7)$$

The balance of the mechanical powers on the motor-transmission subsystem, gives the following relationship:

$$T_m\dot{\varphi} - T_r\dot{\varphi} - T_c\dot{\alpha} = \frac{d}{dt} \left[ \frac{1}{2}(J_m + J_a)\dot{\varphi}^2 + \frac{1}{2}J_b\dot{\alpha}^2 \right] \quad (8)$$

where  $T_m$  indicates the torque generated by the electric motor, that is proportional to armature current  $I$ , according to the known relation  $T_m = k_m I$ . By introducing the transmission ratio  $z$  and the expression of the resistant torque  $T_r$ , given by eq. (6), the torque  $T_c$  acting on the crank can be easily calculated through eq. (8):

$$T_c = zk_m I - zT_0 - z^2\lambda\dot{\alpha} - J_{eq}\ddot{\alpha} \quad (9)$$

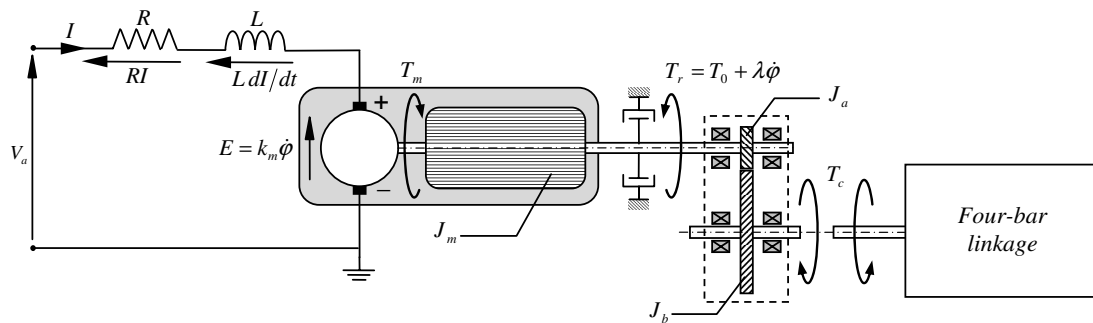

Fig. 2. Schematic of the DC motor and gear-box.

where  $J_{eq} = J_b + (J_m + J_a)z^2$ .

Substituting in (5) the expression of  $T_c$  given by (9) and solving with respect to  $\ddot{\alpha}$ , we obtain:

$$\ddot{\alpha} = \mathcal{F}(\alpha, \dot{\alpha}, I) \quad (10)$$

where

$$\mathcal{F}(\alpha, \dot{\alpha}, I) = \frac{\mathcal{A}(\dot{\alpha}, I) - \mathcal{B}(\alpha, \dot{\alpha})}{J_{eq} + J(\alpha)} \quad (11)$$

$$\mathcal{A}(\dot{\alpha}, I) = z(k_m I - T_0 - z\lambda\dot{\alpha}) \quad (12)$$

$$\mathcal{B}(\alpha, \dot{\alpha}) = \frac{dE_p(\alpha)}{d\alpha} + \frac{1}{2} \frac{dJ(\alpha)}{d\alpha} \dot{\alpha}^2 \quad (13)$$

Eq. (10) shows clearly that the angular acceleration of the crank depends on three variables: the angular position  $\alpha$ , the angular velocity  $\dot{\alpha}$  and the armature current  $I$ .

### C. Model of the velocity controller

If the motor is controlled by a feedback loop, the armature voltage  $V_a$  is determined by the regulator on the basis of the speed error at a given instant of time. Referring to Fig. 3, we take as command signal the desired speed  $\dot{\varphi}_{ref}$ , imposed by an external device. This value is compared with the actual motor speed  $\dot{\varphi}$  (detected by an appropriate transducer installed on the motor axis) and the error signal  $e = \dot{\varphi}_{ref} - \dot{\varphi}$  is sent to the velocity controller. The armature voltage  $V_a$  is then determined as a function of  $e$ . Note that a voltage limiter has been inserted in the block diagram, in order to prevent the motor is supplied with too high voltages during the start-up period. To maintain a constant speed during the operation of the mechanism, we use a proportional, integral and derivative regulator (PID), which represents one of the most popular algorithms employed in industrial field for motion control of electromechanical actuators.

As it is well-known, the PID controller calculates the armature voltage using the following formula:

$$V_a(t) = K_p e(t) + K_i \int_0^t e(t) dt + K_d \frac{de(t)}{dt} \quad (14)$$

where the symbols  $K_p$ ,  $K_i$  and  $K_d$  indicate respectively the *proportional*, *integral* and *derivative* gains.

In order to optimize the dynamic performances of the system, the numerical values of these constants must be carefully selected through a trial-and-error procedure or using a *self-tuning* method.

For the case under consideration, the PID controller has been modified by inserting a time varying gain  $K_p t$  in the proportional contribution, in order to improve the effect of the control action; the corresponding control law assumes then the following expression:

$$V_a(t) = K_p t e(t) + K_i \int_0^t e(t) dt + K_d \frac{de(t)}{dt} \quad (15)$$

The benefits of a time varying proportional gain are known from the literature [1]: indeed, during the start-up period (thus for low values of the time variable  $t$ ), the proportional contribution is low and therefore it does not generate instability effects that could cause unwanted oscillations of the motor speed. However, with increasing time, the proportional action is strengthened gradually and, when added to derivative and integral contributions, it allows the system to reach the required speed with only a little fluctuation around its average value, due to the dynamics of the linkage.

In the more general case all three contributions are simultaneously present, and therefore the armature voltage  $V_a$  can be calculated through the following relationship:

$$V_a(t) = K_p t (\dot{\varphi}_{ref} - \dot{\varphi}) + K_i (\varphi_{ref} - \varphi) + K_d (\ddot{\varphi}_{ref} - \ddot{\varphi}) \quad (16)$$

where  $\dot{\varphi}_{ref}$  and  $\dot{\varphi}$  are respectively the desired speed and the actual speed of the motor.

Substituting eq. (16) in eq. (7) and introducing the transmission ratio  $z$  we obtain:

$$\frac{dI}{dt} = \frac{1}{L} [K_p t (\dot{\varphi}_{ref} - z\dot{\alpha}) + K_i (\varphi_{ref} - z\alpha) + K_d (\ddot{\varphi}_{ref} - z\ddot{\alpha}) - RI - k_m z\dot{\alpha}] \quad (17)$$

As we show in the next section, equation (17) must be coupled to the equation (10), concerning the mechanical part of the system, to form a system of differential equations which constitutes the complete model of the device: in this way it is possible to evaluate the dynamic behaviour of the system as a whole, taking into account the interactions between the various components (linkage, DC motor, velocity controller).

### D. Global model

To implement the global model of the system it is necessary to rewrite the previously obtained differential equations in a form that can easily be solved by a numerical integration method.

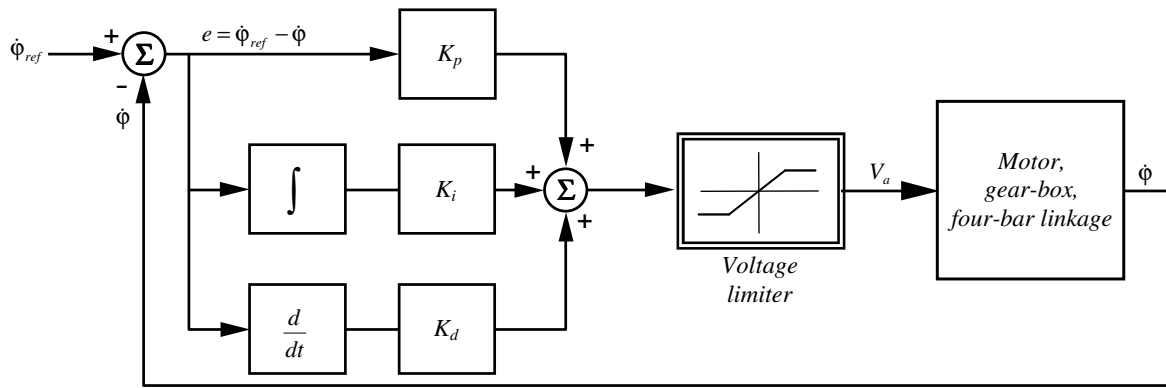

Fig. 3. Velocity control of the DC motor, with PID regulator and feedback loop.

In our analysis we suppose that a constant speed of the DC motor is required. If  $\omega_0$  is the velocity set-point, we have:  $\dot{\varphi}_{ref} = \omega_0$ ,  $\varphi_{ref} = \omega_0 t$  and  $\ddot{\varphi}_{ref} = 0$ . Substituting these relationships into equation (17) and considering the function  $\mathcal{F}$  which gives the angular acceleration  $\ddot{\alpha}$  of the crank (see Equation (10)) we get:

$$\frac{dI}{dt} = \frac{1}{L} [Z_1(\dot{\alpha}, t) + Z_2(\alpha, t) - Z_3(\alpha, \dot{\alpha}, I)] \quad (18)$$

where the functions  $Z_1$ ,  $Z_2$  e  $Z_3$  are defined by the following relationships:

$$\begin{aligned} Z_1(\dot{\alpha}, t) &= K_p t (\omega_0 - z \dot{\alpha}) \\ Z_2(\alpha, t) &= K_i (\omega_0 t - z \alpha) \\ Z_3(\alpha, \dot{\alpha}, I) &= z K_d \mathcal{F}(\alpha, \dot{\alpha}, I) + RI + k_m z \dot{\alpha} \end{aligned} \quad (19)$$

At this point, by introducing the following auxiliary functions:

$$\begin{cases} u_1(t) = \alpha(t) \\ u_2(t) = \dot{\alpha}(t) \\ u_3(t) = I(t) \end{cases} \quad (20)$$

we can rewrite the differential equations (10) and (18) in the form:

$$\begin{cases} \dot{u}_1 = u_2 \\ \dot{u}_2 = \mathcal{F}(u_1, u_2, u_3) \\ \dot{u}_3 = \frac{1}{L} [Z_1(u_2, t) + Z_2(u_1, t) - Z_3(u_1, u_2, u_3)] \end{cases} \quad (21)$$

This system of equations can be solved numerically without particular difficulty, using a software for scientific and technical computing that includes a library of predefined functions for the solution of systems of ordinary differential equations.

### III. DYNAMIC ANALYSIS AND SIMULATION RESULTS

The mathematical model described in the previous sections has been used to simulate the dynamic behaviour of a four-bar linkage driven by a DC motor; both open loop and closed loop configurations are analyzed.

The complete list of the system parameters is shown in Table I. For the solution of the equations we used a 4<sup>th</sup> order Runge-Kutta method with a fixed time step of 1 ms. The speed reference signal for the control loop was set to  $\omega_0 = 30$  rad/s.

The diagrams in Fig. 4 show the time histories of the following variables: motor speed (Fig. 4a, b), supply voltage

(Fig. 4c, d), armature current (Fig. 4e, f), mechanical and electric power (Fig. 4g, h).

The left column shows the results for an open loop configuration: in this case the regulator is bypassed and the motor is powered with a constant voltage equal to 25 Volts; the right column reports the results for a closed loop configuration based on a PID controller having the following parameters:  $K_p = 80$  V/rad,  $K_i = 32$  V/rad,  $K_d = 0.015$  V/(rad s<sup>-2</sup>).

The effect of the speed regulator is clearly visible in the diagrams of Fig. 4a, b: in fact we can observe a little fluctuation of the motor velocity if a PID control is used; on the contrary, for an open loop configuration, the system performance is unacceptable, because the speed variations are too large.

To quantify the effect of the control algorithm it is useful to calculate the performance index  $\chi$ , which is defined as the ratio between the motor speed fluctuation in a cycle and its average value, i.e.:

$$\chi = \frac{\dot{\varphi}_{max} - \dot{\varphi}_{min}}{\dot{\varphi}_{av}} \quad (22)$$

For the open loop configuration we have obtained  $\chi = 54.3\%$ , whereas, for the closed loop configuration, this index is reduced to a few percent: for example, if we consider the time interval between 0.375 s e 0.5 s we have  $\chi = 2.6\%$  (see Fig.4b), but the diagram shows clearly that the speed fluctuation tends to be reduced further, because of the progressive reinforcement of the proportional action, due to the time varying gain  $K_p t$ .

### IV. CONCLUSIONS AND FUTURE DEVELOPMENTS

The paper presented a dynamic model of a mechatronic system consisting of a four-bar linkage, a DC servomotor, a gear-box and a PID controller. Through a specifically developed software some set of simulations were carried out in order to verify the system behaviour for different values of the control parameters and to optimize its dynamic performance, in particular as regards the speed fluctuation of the motor.

The numerical simulations here presented show that, for the case under consideration, it is possible to obtain a good dynamic performance of the mechatronic system, by means of an accurate tuning of the PID control. These results have

TABLE I

Geometrical and inertial parameters of the mechanism		
Cartesian coordinates of the rocker arm pin:	$h_x = 500 \text{ mm}$	$h_y = 50 \text{ mm}$
Link (1) length	$a = 80 \text{ mm}$	
Link (2) length	$b = 500 \text{ mm}$	
Link (3) length	$c = 450 \text{ mm}$	
Polar coordinates of the center of mass (link 1)	$f_1 = 40 \text{ mm}$	$\vartheta_1 = 0^\circ$
Polar coordinates of the center of mass (link 2)	$f_2 = 250 \text{ mm}$	$\vartheta_2 = 0^\circ$
Polar coordinates of the center of mass (link 3)	$f_3 = 225 \text{ mm}$	$\vartheta_3 = 0^\circ$
Mass and moment of inertia (link 1)	$m_1 = 0.6 \text{ kg}$	$J_{G1} = 3.5 \times 10^{-4} \text{ kg m}^2$
Mass and moment of inertia (link 2)	$m_2 = 0.75 \text{ kg}$	$J_{G2} = 1.7 \times 10^{-2} \text{ kg m}^2$
Mass and moment of inertia (link 3)	$m_3 = 0.9 \text{ kg}$	$J_{G3} = 1.7 \times 10^{-2} \text{ kg m}^2$
Motor and gear-box parameters		
Armature resistance:	$R = 1.6 \Omega$	
Armature inductance:	$L = 9 \text{ mH}$	
Torque/Voltage constant:	$k_m = 0.48 \text{ Nm/A} - \text{Vs/rad}$	
Moment of inertia of the motor	$J_m = 13 \times 10^{-4} \text{ kg m}^2$	
Gear (a) moment of inertia	$J_a = 9.8 \times 10^{-5} \text{ kg m}^2$	
Gear (b) moment of inertia	$J_b = 9.8 \times 10^{-5} \text{ kg m}^2$	
Transmission ratio	$z = 1$	
Constant resistant torque on motor axis	$T_0 = 0 \text{ Nm}$	
Viscous friction coefficient	$\lambda = 0.08 \text{ Nms/rad}$	

been obtained by trial and error approach but it is also possible to use appropriate optimization algorithms, which allow to minimize the index  $\chi$ , with respect to the control parameters  $K_p$ ,  $K_i$  and  $K_d$ .

In this case many repeated analyses are required in order to determine the optimal values of the PID parameters and therefore a strong interaction is necessary between the procedure which calculate the dynamic behaviour of the system and the optimization algorithm. This topic represents an interesting research perspective, that could be developed in future activities, both from the theoretical point of view (autotuning of PID controllers coupled to mechanical systems with non-linear dynamics), both from the experimental point of view (validation of calculation models using experimental measurements on a real mechanism).

#### APPENDIX A POSITION ANALYSIS

The following formulas can be used to calculate the angular positions  $\beta$  and  $\gamma$  as function of the crank position  $\alpha$ : (see also [8] [9] for details):

$$\sin \gamma = -\frac{AC + kBD}{A^2 + B^2} \quad \cos \gamma = -\frac{BC - kAD}{A^2 + B^2}$$

$$\sin \beta = \frac{h_y + c \sin \gamma - a \sin \alpha}{b} \quad \cos \beta = \frac{h_x + c \cos \gamma - a \cos \alpha}{b}$$

where:

$$k = \pm 1 \quad (\text{type of assembly})$$

$$A = A(\alpha) = 2c(h_y - a \sin \alpha)$$

$$B = B(\alpha) = 2c(h_x - a \cos \alpha)$$

$$C = C(\alpha) = a^2 - b^2 + c^2 + h_x^2 + h_y^2 - 2a(h_x \cos \alpha + h_y \sin \alpha)$$

$$D = D(\alpha) = \sqrt{A^2 + B^2 - C^2}$$

The cartesian coordinates of point  $G_2$  are:

$$x_{G2} = a \cos \alpha + f_2 \cos(\beta + \vartheta_2) \quad y_{G2} = a \sin \alpha + f_2 \sin(\beta + \vartheta_2)$$

#### APPENDIX B VELOCITY ANALYSIS

The angular velocities  $\dot{\beta}$  and  $\dot{\gamma}$  are given by the following relationships:

$$\dot{\gamma}(\alpha, \dot{\alpha}) = \dot{\alpha}R(\alpha) \quad R(\alpha) = \frac{a \sin[\alpha - \beta(\alpha)]}{c \sin[\gamma(\alpha) - \beta(\alpha)]}$$

$$\dot{\beta}(\alpha, \dot{\alpha}) = \dot{\alpha}Q(\alpha) \quad Q(\alpha) = \frac{a \sin[\alpha - \gamma(\alpha)]}{b \sin[\gamma(\alpha) - \beta(\alpha)]}$$

The velocity components  $\dot{x}_{G2}$ ,  $\dot{y}_{G2}$  of point  $G_2$  are:

$$\dot{x}_{G2} = -a\dot{\alpha} \sin \alpha - f_2\dot{\beta} \sin(\beta + \vartheta_2)$$

$$\dot{y}_{G2} = a\dot{\alpha} \cos \alpha + f_2\dot{\beta} \cos(\beta + \vartheta_2)$$

Therefore, if the symbol  $v_{G2}$  indicates the velocity of point  $G_2$ , we obtain:

$$v_{G2}^2 = \dot{x}_{G2}^2 + \dot{y}_{G2}^2 = a^2\dot{\alpha}^2 + f_2^2\dot{\beta}^2 + 2af_2\dot{\alpha}\dot{\beta}[\sin \alpha \sin(\beta + \vartheta_2) + \cos \alpha \cos(\beta + \vartheta_2)]$$

#### APPENDIX C KINETIC ENERGY OF THE FOUR-BAR LINKAGE

The kinetic energy of the four-bar linkage can be calculated by summing the energies of the three links, that is:

$$E_k = E_{k1} + E_{k2} + E_{k3}$$

where:

$$E_{k1} = \frac{1}{2} J_A \dot{\alpha}^2 \quad J_A = J_{G1} + m_1 f_1^2$$

$$E_{k2} = \frac{1}{2} (m_2 v_{G2}^2 + J_{G2} \dot{\beta}^2)$$

$$E_{k3} = \frac{1}{2} J_D \dot{\gamma}^2 \quad J_D = J_{G3} + m_3 f_3^2$$

Considering now the previously defined functions  $R(\alpha)$  and  $Q(\alpha)$ , the mathematical expression of  $v_{G2}^2$  and the moment of inertia of link 2 about point B  $J_B = J_{G2} + m_2 f_2^2$ , the total kinetic energy of the four-bar linkage can be written in the form (2), where:

$$J(\alpha) = J_A + J_D R^2(\alpha) + m_2 a^2 + J_B Q^2(\alpha) + 2af_2 m_2 Q(\alpha) \{ \sin \alpha \sin[\beta(\alpha) + \vartheta_2] + \cos \alpha \cos[\beta(\alpha) + \vartheta_2] \}$$

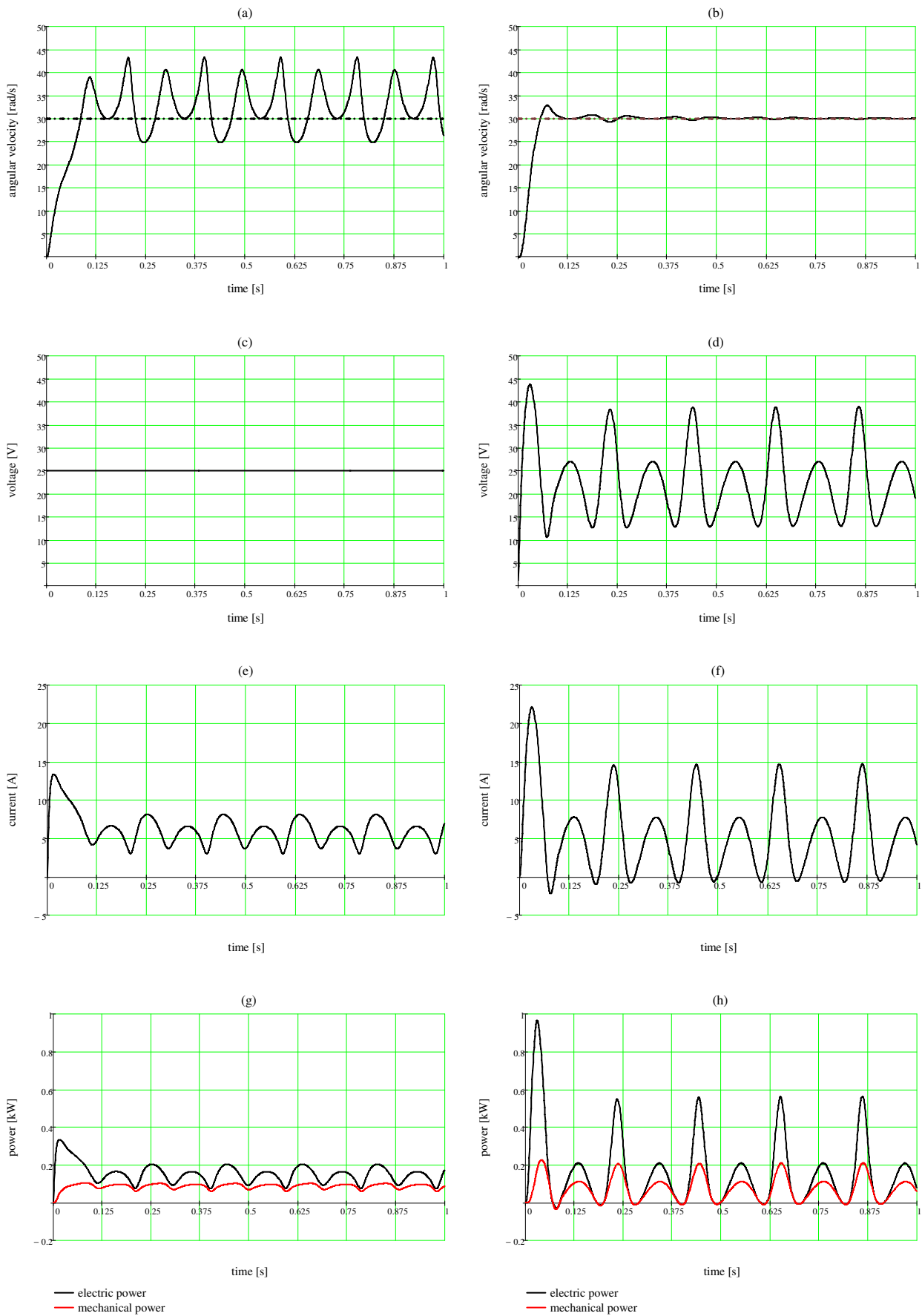

Fig. 4. Simulation results for open loop (left column) and closed loop (right column). The horizontal dashed line in the diagrams a) and b) indicates the velocity set point of the motor  $\omega_0 = 30$  rad/s.

## REFERENCES

- [1] Tao J., Sadler J.P., "Constant speed control of a motor driven mechanism system", *Mechanism and Machine Theory*, **30**(5), 737-748 (1995).
- [2] Lin M.C., Chen J.S., "Experiments toward MRAC design for linkage system", *Mechatronics*, **6**(8), 933-953 (1996).
- [3] Tokuz Dulger L.C., Uyan S., "Modelling, simulation and control of a four-bar mechanism with a brushless servo motor", *Mechatronics*, **7**(4), 369-383 (1997).
- [4] Li Q., Tso S.K., Guo L.S., Zhang W.J., "Improving motion tracking of servomotor-driven closed-loop mechanisms using mass-redistribution", *Mechanism and Machine Theory*, **35**, 1033-1045 (2000).
- [5] Gündoğdu Ö., Erentürk K. "Fuzzy control of a dc motor driven four-bar mechanism", *Mechatronics*, **15**, 423-438 (2005).
- [6] Affi Z., EL-Kribi B., Romdhane L., "Advanced mechatronic design using a multi-objective genetic algorithm optimization of a motor-driven four-bar system", *Mechatronics*, **17**, 489-500 (2007).
- [7] Yan H.S., Yan G.J., "Integrated control and mechanism design for the variable input-speed servo four-bar linkages", *Mechatronics*, **19**, 274-285 (2009).
- [8] Erdman A.G., Sandor G.N., *Mechanism design: analysis and synthesis*, vol. 1., Prentice-Hall, Englewood Cliffs - New Jersey (USA) (1997).
- [9] Magnani P.L., Ruggieri G., *Meccanismi per macchine automatiche* UTET, Torino (Italy) (1986) - in italian.



**Giovanni Incerti** graduated in Mechanical Engineering in 1990 at the University of Brescia, Italy. At the same university he received the Ph.D in Applied Mechanics in 1995. Actually he is associate professor at the University of Brescia and his teaching activity is related to the courses of Mechanical Vibrations, Applied Mechanics and Vibration Control. He is author of papers dealing with the dynamic analysis of cam systems, the mathematical modeling of devices for industrial automation, the mechanism design by optimization techniques and the study of robots and servomechanisms. He took part in researches funded by the Italian Council of Researches (CNR) and by the Italian Ministry of University and Research. Recently he has been scientific coordinator for the University of Brescia inside the National research project *Design and experimental validation of cam transmissions*.