

Automatic Generation Control of Interconnected Power System with Generation Rate Constraints by Hybrid Neuro Fuzzy Approach

Gayadhar Panda, Sidhartha Panda and Cemal Ardil

Abstract—The design of Automatic Generation Control (AGC) system plays a vital role in automation of power system. This paper proposes Hybrid Neuro Fuzzy (HNF) approach for AGC of two-area interconnected reheat thermal power system with the consideration of Generation Rate Constraint (GRC). The advantage of proposed controller is that it can handle the system non-linearities and at the same time the proposed approach is faster than conventional controllers. The performance of HNF controller has been compared with that of both conventional Proportional Integral (PI) controller as well as Fuzzy Logic Controller (FLC) both in the absence and presence of Generation Rate Constraint (GRC). System performance is examined considering disturbance in each area of interconnected power system.

Keywords—Automatic Generation Control (AGC), Dynamic Response, Generation Rate Constraint (GRC), Proportional Integral (PI) Controller, Fuzzy Logic Controller (FLC), Hybrid Neuro-Fuzzy (HNF) Control, MATLAB/SIMULINK.

I. INTRODUCTION

MEGAWATT frequency control or Automatic Generation Control (AGC) problems are that of sudden small load perturbations which continuously disturb the normal operation of an electric energy system. The analysis and design of Automatic Generation Control (AGC) system of individual generator eventually controlling large interconnections between different control areas plays a vital role in automation of power system. The purpose of AGC is to maintain system frequency very close to a specified nominal value to maintain generation of individual units at the most economical value and to keep the correct value of the line power between different control areas. Many investigations in the area of Load Frequency Control (LFC) problem of interconnected

power systems have been reported over the past six decades [1-5].

A number of control strategies have been employed in the design of load frequency controllers in order to achieve better dynamic performance. Among the various types of load frequency controllers, the most widely employed is the conventional proportional integral (PI) controller [8, 9]. Conventional controller is simple for implementation but takes more time and gives large frequency deviation. A number of state feedback controllers based on linear optimal control theory have been proposed to achieve better performance [10,11]. Fixed gain controllers are designed at nominal operating conditions and fail to provide best control performance over a wide range of operating conditions. So, to keep system performance near its optimum, it is desirable to track the operating conditions and use updated parameters to compute the control. Adaptive controllers with self-adjusting gain settings have been proposed for LFC [13-15].

AGC approaches may be classified into two categories as follows:

1. Energy storage system: Examples are pumped storage system, superconducting magnetic energy storage system, battery energy storage system etc. [6, 7].
2. Control strategy: This category focuses on the design of an automatic generation controller to achieve better dynamic performance [8-15].

Literature survey shows that only a few investigations have been carried out using FLC [16, 18]. Among the aforementioned controllers, the most widely employed one is the fixed gain controller, like integral controller or PI controller due to its low cost and high reliability in operation. Fixed gain controllers are designed at nominal operating points and may no longer be suitable in all operating conditions. For this reason, some authors have applied the variable structure control [19, 20] to make the controller insensitive to the system parameter changes. However, this method requires the information of the system states, which are very difficult to predict and collect completely.

In view of the above discussion, the following are the main objectives of the present work:

1. To apply hybrid neuro-fuzzy (HNF) controller for the automatic generation control and tested for the two area interconnected system with and without GRC.

Gayadhar Panda is working as Professor in the Department of Electrical and Electronics Engineering, National Institute of Science and Technology, Berhampur, Orissa, INDIA. (e-mail: p_gayadhar@yahoo.co.in).

Sidhartha Panda is working as Professor in the Department of Electrical and Electronics Engineering, National Institute of Science and Technology, Berhampur, Orissa, INDIA. (e-mail: panda_sidhartha@rediffmail.com).

Cemal Ardil is with National Academy of Aviation, AZ1045, Baku, Azerbaijan, Bina, 25th km, NAA (e-mail: cemalardil@gmail.com).

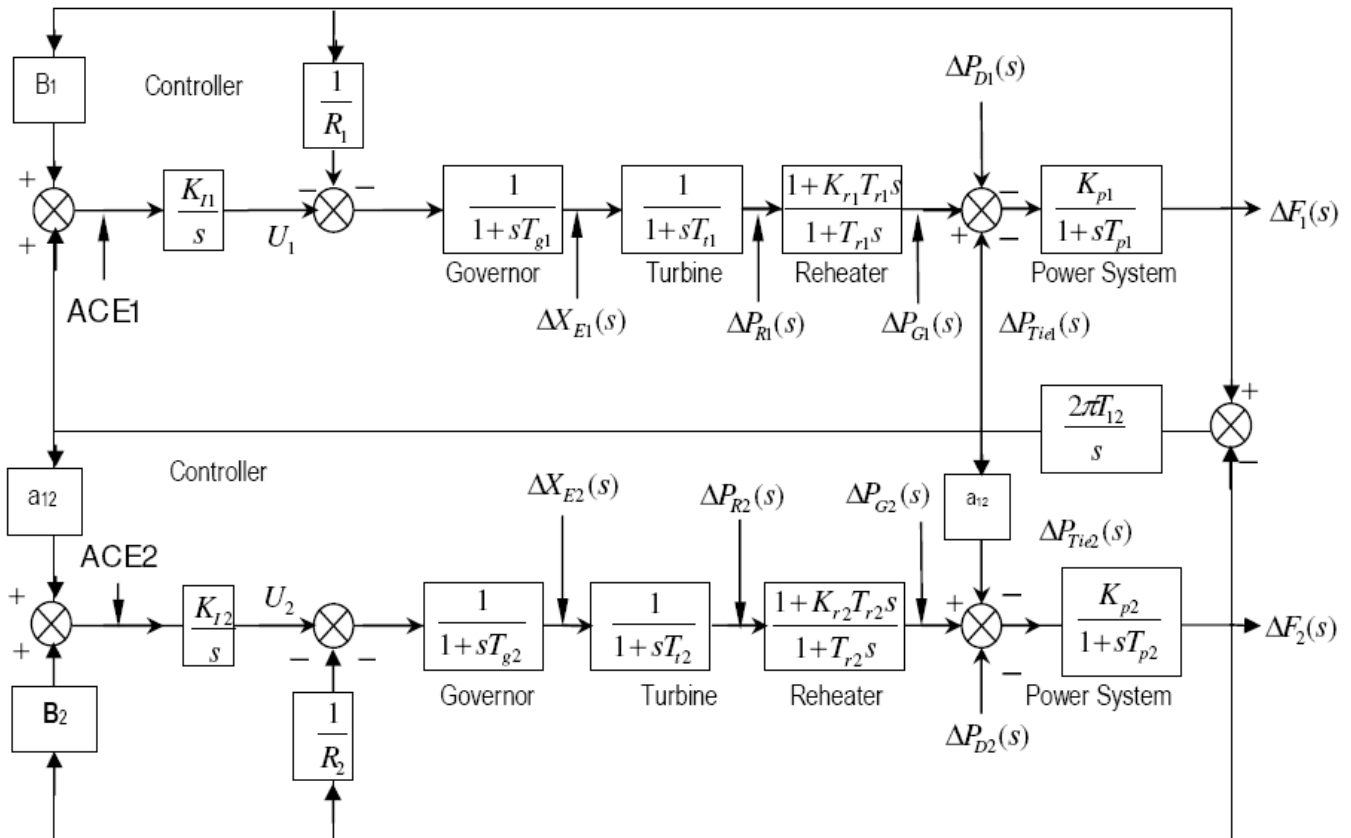

Fig. 1 Transfer function model of two-area reheat thermal system

2. To develop MATLAB/SIMULINK based adaptive networks that are functionally equivalent to fuzzy inference systems.
3. To compare the performance of the Hybrid Neuro-Fuzzy (HNF) controller with conventional PI and Fuzzy Logic Controller (FLC).

II. SYSTEM MODEL

Investigations have been carried out on a two equal area reheat thermal power system considering GRC (Fig.1). A step load perturbation of 1% of nominal loading has been considered in area-1. Here, the tie-line power deviations can be assumed as an additional power disturbance to any area k [12]. For the load frequency control, the proportional integral controller is implemented.

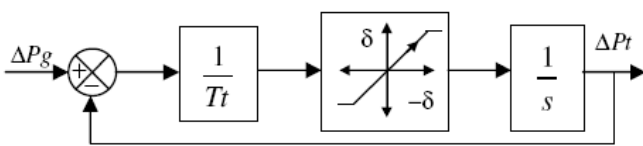

Fig. 2. Nonlinear Turbine Model with GRC

A. Modeling of Two Area system with GRC

In a power system having steam plants, power generation can change only at a specified maximum rate. As described in, adding limiters to the governors can restrict the generation rate for the steam plants. A typical value of the Generation Rate Constraint (GRC) for thermal units is considered as 3%/min., i.e. GRC for the k_{th} subsystem is .

$$\left| \Delta P_{Gk}(t) \right| \leq 0.0005 \text{ p.u. MW / s} \quad (1)$$

Two limiters, bounded by ± 0.0005 are used within the automatic generation controller to prevent the excessive control action. The generation rate constraints for all the areas are taken into account by adding limiters to the turbines as shown in Fig. 2.

B. Automatic Controller

The task of load frequency controller is to generate a control signal U_i that maintains system frequency and tie-line interchange power at predetermined values. The block diagram of the PI controller is shown in Fig. 3. The control input U_i is constructed as follows:

$$U_i = -K_i \int_0^T (ACE_i) dt = -K_i \int_0^T (\Delta P_{Tie_i} + B_i \Delta F_i) dt \quad (2)$$

Taking the derivative of equation (2) yields

$$\dot{U}_i = -K_i (ACE_i) = -K_i (\Delta P_{Tie_i} + B_i \Delta F_i) \quad (3)$$

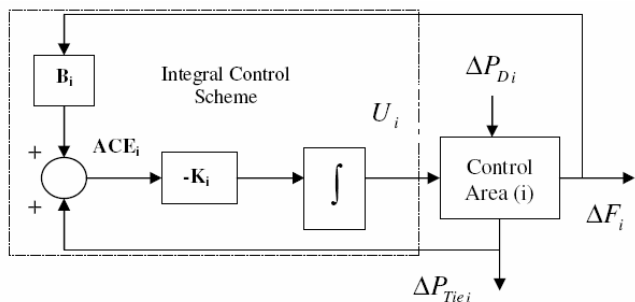

Fig. 3. Conventional PI Controller Installed on i^{th} Area

Automatic Generation Control gives poor performance under different generator loading conditions, and hence the need for Hybrid Neuro-Fuzzy (HNF) Logic base Controller [21] arises. In order to accomplish a satisfactory frequency and tie-line power characteristic over a wide range of operating points, area control error (ACE) and its derivative ($d(ACE)/dt$) were taken as the input signals to the Fuzzy controller. It is known that these variables have significant effects on generators. A modification of the integral gain (K_{i1} and K_{i2}) on the unit is also used to enhance the stability of the system. The stabilizing signals are computed using the standard fuzzy membership function depending on these variables. The performance of the proposed neuro-fuzzy logic base Automatic Generation Control (AGC) is being investigated to have better control.

III. HYBRID NEURO FUZZY (HNF) MODEL

A neuro-fuzzy system is a fuzzy system that uses a learning algorithm derived from neural network theory to determine its parameters (fuzzy sets and fuzzy rules) by processing data samples. In recent years, hybrid neuro-fuzzy(HNF) approach [21] has considerable attention for their useful applications in the fields like control, pattern recognition, image processing, etc. In all these applications there are different neuro-fuzzy applications proposed for different purposes and fields. Hybrid neuro-fuzzy results are obtained from fusion of neural network and fuzzy logic.

A. Fuzzy Controller Modeling

There are three principal elements to a fuzzy logic controller:

- Fuzzification module (Fuzzifier)
- Rule base and Inference engine
- Defuzzification module (defuzzifier)

The general algorithm for a fuzzy system designer can be synthesized as follows:

B. Fuzzifier

The first step in designing a fuzzy controller is to decide which state variables represent the system dynamic performance must be taken as the input signal to the controller. Fuzzy logic uses linguistic variables instead of numerical variables. The process of converting a numerical variable (real number or crisp variables) into a linguistic variable (fuzzy number) is called *Fuzzification*. System variables, which are usually used as the fuzzy controller inputs includes states error, state error derivative, state error integral or etc. In power system, based on previous experience, Area Control Error (ACE) and its derivative ($d(ACE)/dt$) are chosen to be the input signals of fuzzy AGC.

The membership function is a graphical representation of the magnitude of participation of each input. There are different memberships functions associated with each input and output response. In this study, we use the trapezoidal membership function for input and output variables. The number of membership function determines the quality of control which can be achieved using fuzzy controller. As the number of membership function increases, the quality of control improves. As the number of linguistic variables increases, the computational time and required memory increases. Therefore, a compromise between the quality of control and computational time is needed to choose the number of linguistic variables. For the AGC study, five linguistic variables for each of the input and output variables are used to describe them, as in the following Table I.

TABLE I FUZZY LINGUISTIC VARIABLES

NB	Negative Big
NS	Negative Small
ZE	Zero
PS	Positive Big
PB	Positive Small

TABLE II RULE TABLE FOR FUZZY CONTROLLER

		ACE				
		NB	NS	ZE	PS	PB
d(ACE)/dt	NB	NB	NS	ZE	PS	PB
	NS	NS	ZE	PS	PB	PB
	ZE	ZE	PS	PB	PB	PB
	PS	PS	PB	PB	PB	PB
	PB	PB	PB	PB	PB	PB

C. Rule base and inference engine:

The rules are in the following format. If error is A_i , and change in error is B_i then output is C_i . Here the "if" part of a rule is called the *rule-antecedent* and is a description of a process state in terms of a logical combination of atomic fuzzy propositions. The "then" part of the rule is called the rule consequent and is a description of the control output in terms of a logical combination of fuzzy propositions. The rule table for the designed fuzzy controller is given in the Table 2. For two inputs and 5 membership functions, we have derived 25

rules. From the rule table, the rules are manipulated as follows; if the ACE is NB, and its derivative is NB then output is NB.

D. Defuzzification

The reverse of Fuzzification is called *Defuzzification*. The use of Fuzzy Logic Controller (FLC) produces required output in a linguistic variable (fuzzy number). According to real world requirements, the linguistic variables have to be transformed to crisp output. Centre of gravity method is the best well-known defuzzification method and used in this research work. Sugeno type of defuzzification method is adopted in this work. It obtains the center of area occupied by the fuzzy set. It is given by the expression:

$$X = \frac{\int \mu(x)xdx}{\int \mu(x)dx} \quad (4)$$

E. Steps to design HNF Controller

1. Draw the Simulink model with FLC and simulate it with the given rule base.
2. The first step to design the HNF controller is collecting the training data while simulating with FLC.
3. The two inputs, i.e., ACE and d(ACE)/dt and the output signal gives the training data.
4. Use *anfisedit* to create the HNF .fis file.

5. Load the training data collected in Step.1 and generate the FIS with *gbell* MF's.
6. Train the collected data with generated FIS upto a particular no. of *Epochs*.

IV. SIMULATION RESULTS

The proposed scheme utilizes sugeno-type fuzzy inference system controller, with the parameters inside the fuzzy inference system decided by the neural-network back propagation method [22]. The ANFIS is designed by taking ACE and rate of change of ACE as inputs. The MATLAB/SIMULINK model of two-area reheat thermal system with HNF controller is shown in Fig. 4.

Figs. 5 and 6 show the dynamic response of a two area reheat thermal system of HNF controller, FLC and conventional PI controller with and without GRCs for 1% step load perturbation in area 1. In all the Figs. the response with conventional PI controller is shown with dotted lines (legend PI), the response with conventional Fuzzy logic controller is shown with dashed lines (legend FC) and the response with proposed HNF controller is shown with solid lines (legend HNF). It can be seen from Figs. 5 and 6 that even with GRCs the system remains stable and that the responses with and without GRCs are not much different. The simulation results prove that the designed HNF controller is robust in its operation and gives a superb damping performance both for frequency and tie line power deviation compare to its conventional PI as well as FLC counterpart. Besides the simple architecture of the controller it has the potentiality of implementation in real time environment.

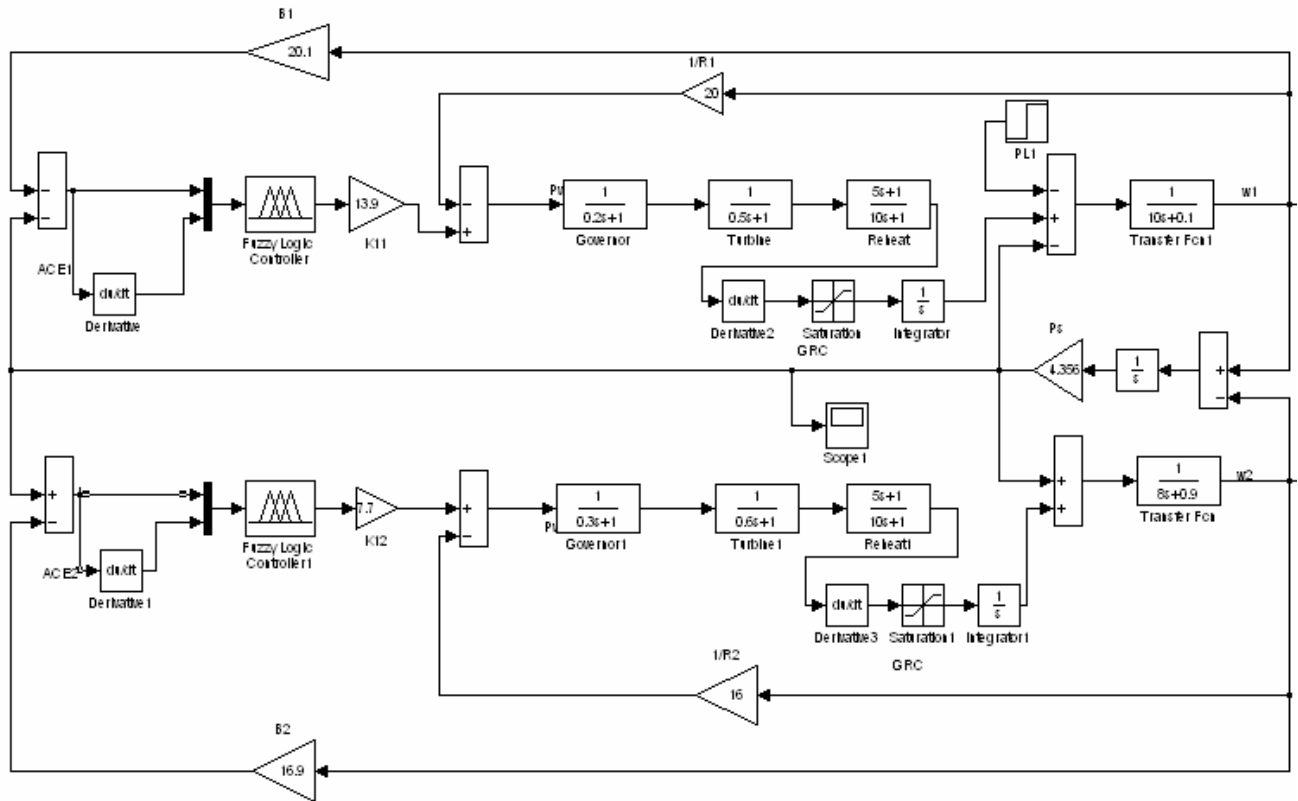
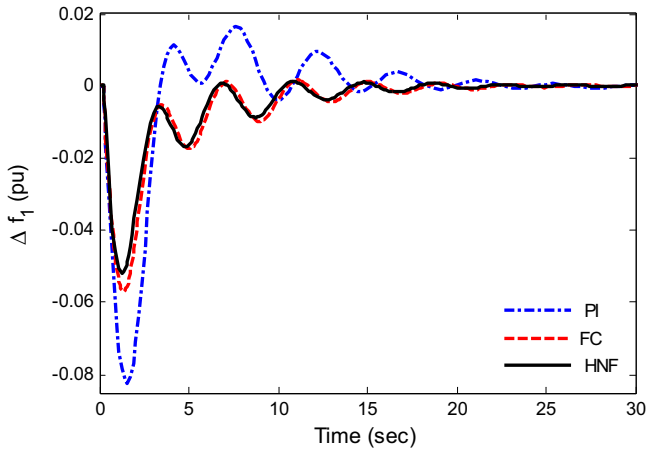
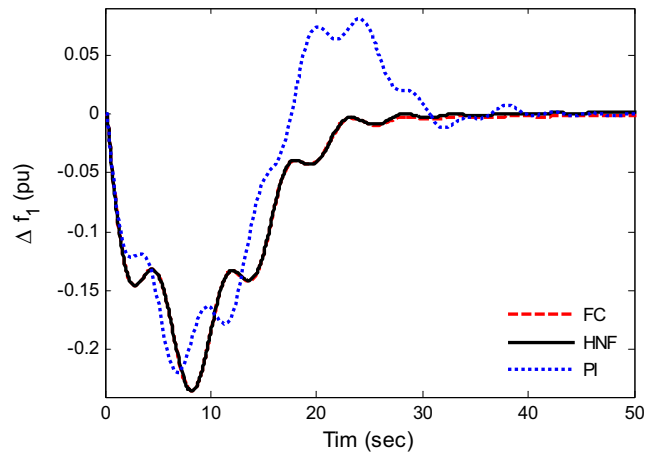

Fig. 4. Block diagram of two-area reheat thermal system with HNF controller simulated in Matlab



(a) Frequency deviation in Area-1 neglecting GRC



(a) Frequency deviation in Area-1 with GRC

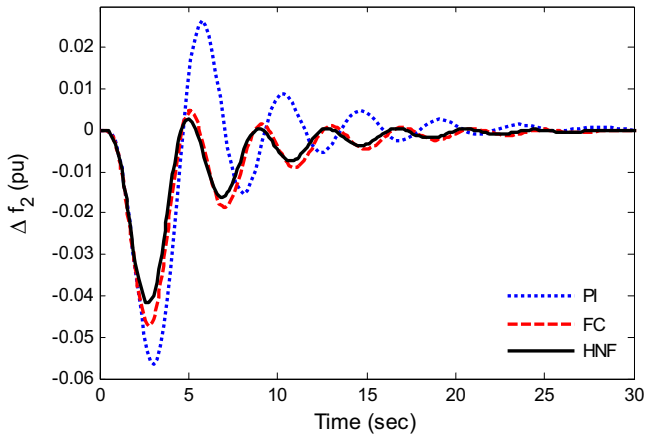

(b) Frequency deviation in Area-2 neglecting GRC

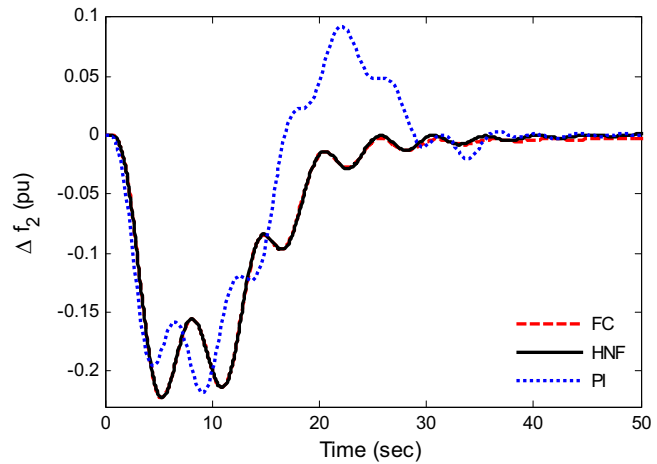

(b) Frequency deviation in Area-2 with GRC

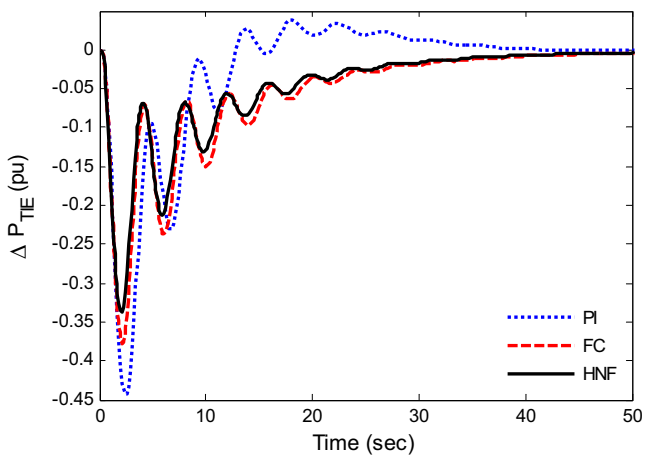

(c) Tie-line power deviation neglecting GRC

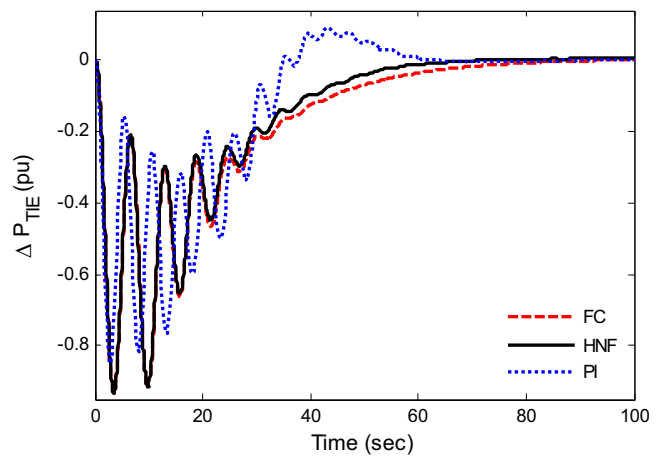

(c) Tie-line power deviation with GRC

Fig. 5. Dynamic response of Two-area reheat thermals system without consideration of generation rate constraint (GRC)

Fig. 6. Dynamic response of Two-area reheat thermals system with generation rate constraint (GRC)

VI. CONCLUSION

In this study, Hybrid Neuro-Fuzzy (HNF) approach is employed for an Automatic Generation Control (AGC) of interconnected power system with and without generation rate constraint (GRC). The effectiveness of the proposed controller in increasing the damping of local and inter area modes of oscillation is demonstrated in a two area interconnected power system. Also the simulation results are compared with a conventional PI controller. The result shows that the proposed intelligent controller is having improved dynamic response and at the same time faster than conventional PI controller. It has been observed that in the presence of stringent GRC of 3% min., the performance of HNF controller is almost same to that of Fuzzy logic Controller (FLC). It can also be observed that there is a slight improvement in performance of the system with HNF controller in comparison to FLC in both cases (i.e. with and without consideration of GRC)

APPENDIX

The nominal system parameters are: $f = 60$ Hz, $R_k = 2.4$ Hz / Unit, $T_g = 0.08$ Sec, $T_r = 10.0$ Sec, $H_k = 5.0$ Sec, $K_r = 0.5$, $T_f = 0.3$ Sec, $2\pi T_{ki} = 0.05$ Mw, $D_k = 0.00833$ pu Mw/Hz

REFERENCES

- [1] A. J. Wood, B. F. Woolenberg, Power Generation Operation and Control, *John Wiley and Sons*, 1984.
- [2] M. Gopal, "Modern control system theory", *Wiley Eastern Ltd.*, 2nd edition, 1993.
- [3] O. I. Elgerd, Electric energy Systems Theory – An Introduction, *McGraw Hill Co.*, 2001.
- [4] I. J. Nagrath and D. P. Kothari, Power System Engineering, *McGraw Hill Co.*, 1998.
- [5] G. W. Stagg and A. H. El-Abiad, Computer Methods in Power System Analysis, *McGraw Hill Co.*, 1985.
- [6] H.J. Kunish, K.G. Kramer and H. D. Dominik, "Battery energy storage – Another option for load-frequency control and instantaneous reserve", *IEEE Trans. Energy Convers.*, Vol. EC-1, No. 3, Sept. 1986, pp. 46-51.
- [7] S. Banerjee, J.K. Chatterjee and S.C. Tripathy, "Application of magnetic energy storage unit as load frequency stabilizer", *IEEE Trans. Energy Convers.*, Vol. 5, No. 1, March 1990, pp. 46-51.
- [8] N. Jaleeli, L. VanSlyck, D. Ewart, L. Fink, and A. Hoffmann, "Understanding automatic generation control", *IEEE Trans. Power Syst.*, Vol. 7, No. 3, pp. 1106-1122, Aug. 1992.
- [9] M. L. Kothari, J. Nanda, D. P. Kothari, and D. Das, "Discrete-mode automatic generation control of a two-area reheat thermal system with new area control error", *IEEE Trans. Power Syst.*, Vol. 4, No. 2, pp. 730-738, May 1989.
- [10] K.Venkateswarlu and A.K. Mahalanabis, "Load frequency control using output feedback", *Journal of The Institution of Engineers (India)*, pt. EI-4, Vol. 58, pp. 200-203, Feb. 1978.
- [11] M. Aldeen and H. Trinh, "Load frequency control of interconnected power system via constrained feedback control schemes", *Computer and Electrical Engineering*, Vol. 20, No. 1, 1994, pp. 71-88.
- [12] A.M.Panda, "Automatic generation control of multi area interconnected power system considering non linearity due to governor dead band", *Archives of Control Sciences*, Vol. 7(XLIII), no.3-4, pp. 285-299, 1998.
- [13] M. Sheirah and M. M. Abd, "Improved load frequency self tuning regulator", *Int. J. Control*, Vol. 39, No. 1, 1984, pp. 143-158.
- [14] K. Yamashita, and H. Miyagi, "Multivariable Self-tuning regulator for load frequency control system with interaction of voltage on Load Demand", *IEE Proceedings-D*, Vol. 138, No. 2, March 1991.
- [15] J. Kannish, et al, "Microprocessor-Based Adaptive load frequency control", *IEE Proceedings-C*, Vol. 131, No. 4, July 1984.
- [16] S. Mishra, A.K. Pradhan and P.K. Hota, "Development and Implementation of a Fuzzy logic based constant speed DC Drive",

Journal of Electrical Division of Institution of Engineers (India), Vol. 79, pp. 146-149, Dec. 1998.

- [17] J.Lee, "On methods for improving performance of PI-type fuzzy logic controllers", *IEEE Trans. On Fuzzy Systems*, Vol. 1, No. 4, pp. 298, Nov. 1993.
- [18] G.A.Chown and R.C.Hartman, "Design and experience with a Fuzzy Logic Controller for Automatic Generation Control (AGC)", *IEEE Trans. Power Syst.*, Vol. 13, No. 3, pp. 965-970, Nov. 1998.
- [19] W. C. Chan and Y. Y. Hsu, "Automatic Generation of Interconnected Power Systems using Variable Structure Controllers", *IEE Proc.*, pt. C, Vol. 128, No. 5, Sept.1981, pp. 269-279.
- [20] A. Kumar, O. P. Malik and G. S. Hope, "Variable Structure System Control Applied to AGC of an Inter-Connected Power System", *IEEE Proc., Gener. Transm. Distrib.*, Vol. 132, No. 1, 1985, pp. 23-29.
- [21] J.R. Jang, "ANFIS: Adaptive-network-Based Fuzzy Inference System", *IEEE Trans. On Systems, Man and Cybernetics*, Vol. 23, No.3, pp. 665-685, May. 1993.
- [22] Gayadhar Panda, Sidhartha Panda and C. Ardil, "Hybrid Neuro Fuzzy Approach for Automatic Generation Control of Two-Area Interconnected Power System", *International Journal of Computational Intelligence*, Vol. 5, No. 1, pp. 80-84, 2009.



Gayadhar Panda was born in Orissa, India, in 1970. He received the B.E. degree in electrical engineering from the Institution of engineers (I), the M.E. degree in electrical engineering from Bengal Engineering College, Shibpur, Howrah, India, and the Ph.D. degree in electrical engineering from Utkal University, Orissa, India, in 1996, 1998, and 2007, respectively. Since 1999, he

has been with the Department of Electrical and Electronics Engineering, Faculty of Engineering, National Institute of Science and Technology, Berhampur, Orissa, India where he is currently a Professor. His research interests are in the areas of stability aspects of power transmission, power electronics, and development of renewable energy. Dr. G. Panda is a member of the IE and ISTE of India.



Sidhartha Panda is a Professor at National Institute of Science and Technology (NIST), Berhampur, Orissa, India. He received the Ph.D. degree from Indian Institute of Technology, Roorkee, India in 2008, M.E. degree in Power Systems Engineering in 2001 and B.E. degree in Electrical Engineering in 1991. Earlier he worked as Associate Professor in KIIT University, Bhubaneswar, India and VITAM College of Engineering,

Andhra Pradesh, India and Lecturer in the Department of Electrical Engineering, SMIT, Orissa, India. His areas of research include power system transient stability, power system dynamic stability, FACTS, optimisation techniques, distributed generation and wind energy.

Cemal Ardil is with National Academy of Aviation, AZ1045, Baku, Azerbaijan, Bina, 25th km, NAA