

Single-qubit quantum gates using magneto-optic Kerr effect

Pradeep Kumar K

Abstract—We propose the use of magneto-optic Kerr effect (MOKE) to realize single-qubit quantum gates. We consider longitudinal and polar MOKE in reflection geometry in which the magnetic field is parallel to both the plane of incidence and surface of the film. MOKE couples incident TE and TM polarized photons and the Hamiltonian that represents this interaction is isomorphic to that of a canonical two-level quantum system. By varying the phase and amplitude of the magnetic field, we can realize Hadamard, NOT, and arbitrary phase-shift single-qubit quantum gates. The principal advantage is operation with magnetically non-transparent materials.

Keywords—Quantum Computing, Qubit, Magneto-Optic Kerr effect (MOKE), Magneto-optical interactions, Continuous variables

I. INTRODUCTION

Quantum computation jump started with Peter Shor's discovery of an algorithm to factor long composite numbers into its factors [1]. Although the algorithm has been experimentally tested only for small numbers, theoretical and experimental advances in the field of quantum computation have been rather spectacular. Implementing quantum computing algorithms requires physical realization of quantum gates that manipulates qubits. It is known that single-qubit gates plus at least one gate that acts non-trivially on a qubit (eg., a CNOT gate) can realize n -qubit operations thus forming a set of universal quantum gates [2–4].

A single-qubit gate can be realized as a unitary transformation of the state of a two-level quantum system. Since quantum mechanical effects are easy to observe in single-photons, photonic technology has emerged as a strong candidate to implement quantum computers [5]. Photonic technology to implement quantum logic can be entirely linear (KLM protocol [6, 7]) or involve nonlinear elements [7]. Nonlinear electro-optic effects such as Pockel's and Kerr effects are used to realize quantum gates. Time-bin and frequency-coding schemes, first developed for quantum key distribution [8–10], have also been used to implement quantum gates. The last two schemes use electro-optic modulators to realize quantum gates.

Magneto-optic Kerr effect (MOKE) is widely used to determine the domains of magnetic materials. Unlike Faraday effect, which can only be observed in magnetically transparent media, MOKE can be observed in materials that are magnetically non-transparent. Depending on the orientation of magnetic field, MOKE can be classified in polar, longitudinal, and transverse configurations. However in most materials magnitude of MOKE is quite low and needs to be enhanced by employing a stack of dielectric layers [11–13].

Pradeep Kumar K is with Department of Electrical Engineering, Indian Institute of Technology Kanpur, Kanpur-208016, India. Email: pradeepk@iitk.ac.in

In this paper, we propose the use of MOKE to realize single-qubit quantum gates—Hadamard, NOT, and phase-shift. We consider longitudinal MOKE in reflection geometry. The bias magnetic field is parallel to both the plane of incidence of light wave and surface of the film. In the absence of the magnetic field incident photons undergo ordinary reflection. Application of the bias field changes polarization of the incident photon and imparts a phase-shift. Specifically, an incident transverse electric (TE) polarized photon acquires a transverse magnetic (TM) polarization upon reflection. The quantum Hamiltonian describing the interaction of quantized light wave (photon) and the applied magnetic field is of the form: $\gamma |\omega_0; \text{TE}\rangle \langle \omega_0; \text{TM}| + \gamma^* |\omega_0; \text{TM}\rangle \langle \omega_0; \text{TE}|$, where γ is the coupling coefficient which includes both Fresnel reflection and MOKE. Here $|\omega_0; \text{TE}\rangle$ and $|\omega_0; \text{TM}\rangle$ represent TE and TM polarized photon states respectively. The coefficient γ depends on the applied magnetic field. By varying the phase and amplitude of γ , we can realize various single-qubit quantum gates. The advantages of the proposed scheme are:

- easy realization of gates using metallic and magnetic materials,
- ease of integration as the gates can be realized in multi-layer thin film structures, and
- efficient operation in the C-band (1550nm) making it suitable for photonic communications.

The rest of the paper is organized as follows. In section II, we derive the Hamiltonian for MOKE interactions in a slab waveguide. While we assume a single-layer film in discussing the Hamiltonian, our results can be easily extended to multi-layer thin film structures. In section III, we show how MOKE can be used to realize single-qubit gates. Finally, we conclude by summarizing our results.

II. MOKE

Magneto-Optic Kerr effect (MOKE) results in modification of the state of polarization of the incident beam of light when reflecting off a metallic or magnetic material. MOKE is usually classified into three types based on the orientation of the magnetization vector with respect to the plane of incidence and surface of the film: polar, longitudinal, and transverse. These configurations and associated coordinate references are shown in Fig.1. The direction of propagation is assumed to be along the z -axis, while the film is in the $x-y$ plane. For our purpose, we assume that the film is infinite in extent along x and y directions. We also assume that the second medium is sufficiently thick so as to simplify the interaction Hamiltonian.

The incident beam of light of angular frequency, ω_0 rad/s, in general consists of transverse electric (TE) and transverse

magnetic (TM) components. Classically the electric field can be written as a vector (called Jones vector): $[e_p^+ \ e_s^+]$, where p denotes TM and s denotes TE mode respectively, and $+$ denotes wave traveling along positive z direction as shown in Fig.2. The reflected fields are related to incident fields as

$$\begin{bmatrix} e_p^- \\ e_s^- \end{bmatrix} = \begin{pmatrix} r_{pp} & r_{ps} \\ r_{sp} & r_{ss} \end{pmatrix} \begin{bmatrix} e_p^+ \\ e_s^+ \end{bmatrix}, \quad (1)$$

where r_{pp} and r_{ss} are Fresnel reflection coefficients of TM and TE modes respectively. The coefficients r_{ps} and r_{sp} include MOKE which determines the coupling of TM and TE modes.

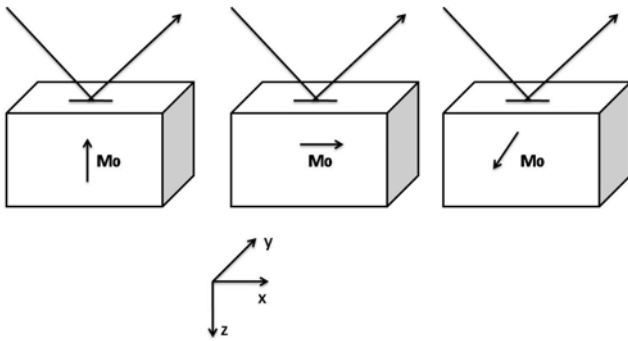

Fig. 1. Polar, longitudinal, and transverse MOKE configurations. M_0 is the saturation magnetization.

To extend the above formalism to single photon MOKE, we consider quantized optical modes interacting with the magnetization vector. We should consider both guided and evanescent modes at an interface for complete representation of reflected optical fields which restricts the values of the propagation constant of incident and reflected fields. The incident field in the absence of any interaction is described by the Hamiltonian:

$$H_0 = \sum_k \hbar\omega_k \left(a_{ip,k}^\dagger a_{ip,k} + a_{is,k}^\dagger a_{is,k} \right), \quad (2)$$

where we have neglected the terms corresponding to zero-point energy. The summation in (2) runs over different values of propagation vector k . The interaction between optical field and the magnetization of the film, which constitutes MOKE, can be modeled by the effective permittivity tensor [14]:

$$\epsilon = \epsilon_0 \begin{bmatrix} \epsilon_r & jQM_z & -jQM_y \\ -jQM_z & \epsilon_r & jQM_x \\ jQM_y & -jQM_x & \epsilon_r \end{bmatrix}, \quad (3)$$

where $\mathbf{M} = \hat{x}M_x + \hat{y}M_y + \hat{z}M_z$ is the magnetization vector and ϵ_r is the permittivity of the film. In the absence of MOKE, the film is assumed to be isotropic. The non-zero components of \mathbf{M} are determined by the type of configuration (polar, longitudinal, and transverse). Since transverse configuration (non-zero M_y) does not symmetrically couple TE and TM polarizations, we ignore this configuration in further analysis.

For the longitudinal MOKE configuration ($\mathbf{M} = \hat{x}M_0$), interaction Hamiltonian takes the form:

$$H_I = jQM_0 E_y^* E_z - jQM_0 E_z^* E_y, \quad (4)$$

which provides coupling between TE and TM modes. It is important to note that for normal incidence in which the electric field lies along x -axis, the interaction Hamiltonian is zero which we expect for longitudinal MOKE. For polar MOKE, the interaction Hamiltonian takes the form:

$$H_I = jQM_0 E_y^* E_x - jQM_0 E_x^* E_y, \quad (5)$$

which again couples the TE and TM modes. However, due to the different field components in (4) and (5), the signs of reflection coefficients r_{sp} and r_{ps} are different. In the following, we consider only longitudinal MOKE. Our results can be modified easily for polar MOKE.

To go over to the quantum domain, we replace the classical field components E_y and E_z by their quantum counterparts a_s and a_p respectively, to obtain the quantum interaction Hamiltonian:

$$H_I = \sum_k (\gamma a_s^\dagger a_p - \gamma^* a_p^\dagger a_s). \quad (6)$$

where γ is the coupling constant. The first term represents the creation of a TE polarized photon of angular frequency ω_0 from a TM polarized photon of the same frequency. Similarly, the second term represents the destruction of a TE polarized photon to yield a TM polarized photon. Thus, the Hamiltonian in (6) represents a canonical two-level quantum system with TM and TE photons considered as “ground” and “excited” states respectively. We recast the Hamiltonian (6) in Schrödinger picture as

$$H_I = j\hbar (\gamma |s\rangle \langle p| + \gamma^* |p\rangle \langle s|), \quad (7)$$

where we have denoted the TM and TE modes by $|p\rangle$ and $|s\rangle$ respectively. In the next section, we make use of the above Hamiltonian to implement single-qubit gates.

III. IMPLEMENTING SINGLE-QUBIT GATES

In this section we implement single-qubit gates by associating TM and TE polarized photons, $|p\rangle$ and $|s\rangle$ with logical qubits $|0\rangle$ and $|1\rangle$. We start by noting that the incident photon can be expressed as a qubit,

$$|\psi(t)\rangle = A(t) |p\rangle + B(t) |s\rangle, \quad |A(t)|^2 + |B(t)|^2 = 1, \quad \forall t,$$

which evolves according to Schrödinger’s equation

$$j\hbar \frac{\partial}{\partial t} |\psi(t)\rangle = H_I |\psi(t)\rangle.$$

Substituting for H_I from (7), and solving the resulting equations, we have

$$A(t) = C \cos(\kappa t) + D \sin(\kappa t) \quad (8a)$$

$$B(t) = e^{-j\phi} [C \sin(\kappa t) - D \cos(\kappa t)], \quad (8b)$$

where C and D are constants that depend on initial conditions and $\gamma = \kappa e^{j\phi}$, κ being a real constant¹. The phase ϕ also comes from the phase of the SW when $m_z(t) = \text{Re}(m_{0z}(x) \exp(j[\Omega t - \mathbf{k}_{\text{SW}} \cdot \mathbf{r} + \phi]))$. Various single-qubit gates (transformations) can be implemented by changing the coupling coefficient κ and phase ϕ . An initial TM polarized

¹We have absorbed $j\hbar$ in defining γ .

photon (with $A(0) = 1$ and $B(0) = 0$) of angular frequency ω_0 rad/s, represented by the ket $|p\rangle$ transforms into the state,

$$|p\rangle \rightarrow \cos(\kappa T) |p\rangle + e^{-j\phi} \sin(\kappa T) |s\rangle \equiv |+\rangle, \quad (9)$$

at time $t = T$. Similarly, an initial TE polarized mode (with $A(0) = 0$ and $B(0) = 1$) transforms into the state,

$$|s\rangle \rightarrow -e^{j\phi} \sin(\kappa T) |p\rangle + \cos(\kappa T) |s\rangle \equiv |-\rangle, \quad (10)$$

A. Hadamard gate

The Hadamard gate is defined by the following transformations on the qubits $|0\rangle$ and $|1\rangle$:

$$U_H |0\rangle = \frac{1}{\sqrt{2}} (|0\rangle + |1\rangle) \quad (11a)$$

$$U_H |1\rangle = \frac{1}{\sqrt{2}} (|0\rangle - |1\rangle). \quad (11b)$$

We can realize single-qubit Hadamard gate by letting the coupling constant $\kappa T = \pi/4$ and phase $\phi = 0$ in (9) and (10) and redefining the global phase:

$$U_H |p\rangle = \frac{1}{\sqrt{2}} (|p\rangle + |s\rangle) \quad (12a)$$

$$U_H |s\rangle = e^{j\pi} \frac{1}{\sqrt{2}} (|p\rangle - |s\rangle). \quad (12b)$$

B. Phase-shift gate

A phase-shift gate imparts a phase difference of ϕ between $|0\rangle$ and $|1\rangle$ as in

$$U_P(\phi) (c_0 |0\rangle + c_1 |1\rangle) = c_0 |0\rangle + e^{j\phi} c_1 |1\rangle. \quad (13)$$

We can implement phase-shift gate by applying a spin wave with phase ϕ (See (9) and (10)).

C. NOT or inverter

Often it is required to perform the transformations, $|0\rangle \rightarrow |1\rangle$ and $|1\rangle \rightarrow |0\rangle$. We can perform these transformations by letting $\kappa T = \pi/2$ (the phase ϕ is not relevant). However, this requires higher microwave power which leads to multiple TE \leftrightarrow TM interactions. We can avoid the nonlinear effects by first transforming $|\omega_0 - \Omega\rangle$ into $|+\rangle$ with $\kappa T = \pi/4$ and $\phi = \phi_1$ (See 9) and then transform $|+\rangle$ into

$$\frac{1}{2} \left(1 - e^{j(\phi_2 - \phi_1)} \right) |p\rangle + \frac{1}{2} \left(e^{j-\phi_2} + e^{j-\phi_1} \right) |s\rangle. \quad (14)$$

We then choose $|\phi_2 - \phi_1| = 0$ to obtain the transformation $|p\rangle \rightarrow |s\rangle$. The various implementations are summarized in Fig. 2.

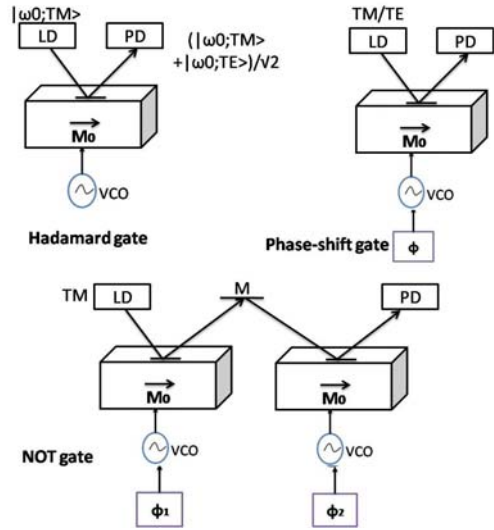

Fig. 2. Implementing single-qubit quantum gates using MOKE. LD: Laser diode, PD: photodetector, M: mirror. In the NOT gate, the two VCO's are synchronized with each other. It is also possible to simply split the VCO signal of frequency Ω to feed both the waveguides. The coupling constant κT is taken to be $\pi/4$.

IV. COHERENT STATE QUANTUM GATES

As an alternative to encoding qubits as single-photons, it is possible to encode them as coherent states. This is called continuous variable encoding. In this section, we show that quantum gates can be implemented by letting coherent states of light interact with SWs. From the transformations (9) and (10) we propose the form of the temporal evolution of the operators a_p and a_s :

$$a_p(t = T) = \frac{1}{\sqrt{2}} \left(e^{j\phi} a_s(0) + a_p(0) \right), \quad (15a)$$

$$a_s(t = T) = \frac{1}{\sqrt{2}} \left(a_s(0) - e^{j\phi} a_p(0) \right), \quad (15b)$$

where ϕ is the phase of the SW component $m_z(t)$. An initial TM polarized coherent state, $|\alpha\rangle_{\text{TM}}$ of frequency ω_0 rad/s and average photon number $|\alpha|^2$ can be expressed as,

$$|\alpha; 0\rangle_{\text{TM}} = e^{(\alpha a_p^\dagger - \alpha^* a_p)} |0\rangle,$$

where $|0\rangle$ is the vacuum state of the TM mode. Substituting for a_p^\dagger and a_s and using the fact that TM and TE modes commute with each other, we can show that at $t = T$, the state $|\alpha\rangle_{\text{TM}}$ transforms into

$$|\alpha\rangle_{\text{TM}} \rightarrow |\cos(\kappa T)\alpha\rangle_{\text{TM}} \otimes |e^{-j\phi} \sin(\kappa T)\alpha\rangle_{\text{TE}} \quad (16)$$

where \otimes denotes direct tensor product. The average photon number in the TM and TE modes is $\cos^2(\kappa T)|\alpha|^2$ and $\sin^2(\kappa T)|\alpha|^2$ respectively. The average photon number in the TM and TE modes can be controlled by changing the coupling constant κT .

It is easy to see that the transformation (16) can implement Hadamard and phase-shift gates. To implement the former, we choose $\kappa T = \pi/4$ and $\phi = 0$. Phase-shift gate can be implemented by modulating the coherent state $|\alpha\rangle_{\text{TM}}$ by applying the magnetic field with a phase ϕ . Since coherent

states are much easier to generate and detect than single-photons, encoding qubits as phase of a coherent state offers attractive and cost-effective alternative to single-photon qubit gates.

V. CONCLUSIONS

We described the use of magneto-optic Kerr effect (MOKE) to implement various single-qubit quantum gates. A TM polarized photon of frequency ω_0 scatters off from a film and results in a superposition of TM and TE polarized photon: $\cos(\kappa T) |p\rangle + e^{j\phi} \sin(\kappa T) |s\rangle$. Single-qubit gates—Hadamard and phase-shift—can be implemented by appropriate choices of κT and ϕ . We also showed that MOKE can be used to realize continuous variable encoding of qubits.

REFERENCES

- [1] P. Shor, "Algorithms for quantum computation: discrete logarithms and factoring," in *Foundations of Computer Science, 1994 Proceedings., 35th Annual Symposium on*, 1994, pp. 124–134.
- [2] D. P. DiVincenzo, "Two-bit gates are universal for quantum computation," *Phys. Rev. A*, vol. 51, no. 2, pp. 1015–1022, Feb 1995.
- [3] L. Seth, "Almost any quantum logic gate is universal," *Phys. Rev. Lett.*, vol. 75, no. 2, pp. 346–349, Jul 1995.
- [4] P. Kaye, R. Laflamme, and M. Mosca, *An introduction to quantum computing*. Oxford University Press, 2007.
- [5] J. L. O'Brien, A. Furusawa, and J. Vuckovic, "Photonic quantum technologies," *Nature*, pp. 687–695, 2009.
- [6] E. Knill, R. Laflamme, and G. J. Milburn, "A scheme for efficient quantum computation with linear optics," *Nature*, vol. 409, p. 46, 2001.
- [7] P. Kok *et al.*, "Linear optical quantum computing with photonic qubits," *Reviews of Modern Physics*, vol. 79, no. 135, 2007.
- [8] N. Gisin, G. Ribordy, W. Tittel, and H. Zbinden, "Quantum cryptography," *Rev. Mod. Phys.*, vol. 74, no. 1, pp. 145–195, 2002.
- [9] J. M. Merolla, Y. Mazurenko, J. P. Goedgebuer, and W. T. Rhodes, "Phase modulation transmission system for quantum cryptography," *Optics Letters*, vol. 24, no. 2, pp. 104–106, 1999.
- [10] P. Kumar and A. Prabhakar, "Evolution of quantum states of light in an electro-optic phase modulator," *IEEE Journ. of Quant. Electron.*, vol. 45, no. 2, 2009.
- [11] C. C. Robinson, "Longitudinal magneto-Optic scattering from thin solid films," *J. Opt. Soc. Am.*, vol. 53, p. 681, 1963.
- [12] R. P. Hunt, "Magneto-Optic scattering from thin solid films," *J. of Appl. Phys.*, vol. 38, no. 4, pp. 1652–1671, 1967.
- [13] M. Gaugitsch and H. Hauser, "Magneto-Optical light modulator-Part II," *J. of Lightwave Tech.*, vol. 17, no. 12, 1999.
- [14] L. D. Landau and E. M. Lifshitz, *Electrodynamics of continuous media*, 2nd ed. Butterworth-Heinemann, 1984.