

On-Line Geometrical Identification of Reconfigurable Machine Tool using Virtual Machining

Alexandru Epureanu, and Virgil Teodor

I. INTRODUCTION

Abstract—One of the main research directions in CAD/CAM machining area is the reducing of machining time.

The feedrate scheduling is one of the advanced techniques that allows keeping constant the uncut chip area and as sequel to keep constant the main cutting force. They are two main ways for feedrate optimization. The first consists in the cutting force monitoring, which presumes to use complex equipment for the force measurement and after this, to set the feedrate regarding the cutting force variation. The second way is to optimize the feedrate by keeping constant the material removal rate regarding the cutting conditions.

In this paper there is proposed a new approach using an extended database that replaces the system model.

The feedrate scheduling is determined based on the identification of the reconfigurable machine tool, and the feed value determination regarding the uncut chip section area, the contact length between tool and blank and also regarding the geometrical roughness.

The first stage consists in the blank and tool monitoring for the determination of actual profiles. The next stage is the determination of programmed tool path that allows obtaining the piece target profile.

The graphic representation environment models the tool and blank regions and, after this, the tool model is positioned regarding the blank model according to the programmed tool path. For each of these positions the geometrical roughness value, the uncut chip area and the contact length between tool and blank are calculated. Each of these parameters are compared with the admissible values and according to the result the feed value is established.

We can consider that this approach has the following advantages: in case of complex cutting processes the prediction of cutting force is possible; there is considered the real cutting profile which has deviations from the theoretical profile; the blank-tool contact length limitation is possible; it is possible to correct the programmed tool path so that the target profile can be obtained.

Applying this method, there are obtained data sets which allow the feedrate scheduling so that the uncut chip area is constant and, as a result, the cutting force is constant, which allows to use more efficiently the machine tool and to obtain the reduction of machining time.

Keywords—Reconfigurable machine tool, system identification, uncut chip area, cutting conditions scheduling.

Manuscript received September 27, 2006. This work was supported by National Excellence Research Programe CEEEX no. 22/2005 of “Dunarea de Jos” University of Galati.

Alexandru Epureanu, “Dunarea de Jos” University of Galati, Romania.

Virgil Teodor, “Dunarea de Jos” University of Galati, Romania (e-mail: virgil.teodor@ugal.ro).

It is known the fact that the control of the force which emerges at cutting machining drives to important economically advances by increasing productivity and surface quality.

Two main ways to maintain the cutting force in more closed limits were developed.

The first approach uses force transducers so the feed is modified as answer to the variation of machining forces. The adaptive controller on-line determines the process model parameters and corresponding to these, adjusts the controller, eliminating the need of off-line calibration tests. However, the systems have a very complex behavior and it is difficult to analyze and implement this approach, since the force direction cannot be determined [1], [7], [8].

Another approach proposes the adjustment of feed value based on the predictive analysis of the cutting force. One considers that the optimizing based on the process simulation allows a better machining process control, especially in cases of complex cutting processes [2], [3], [6].

In this paper a new approach is proposed using the *extended database* that will replace the RMT model. Based on the extended database the predictive analysis of cutting force is made based on the determination of the chip area detached in the machining process.

We consider that this manner has some advantages:

- in case of complex cutting processes, where the cutting depth and the chip width have important variations with the change of tool position, and in case of processes where the cutting is not continuous (generation by rolling with rack-gear tool or with gear-shaped tool), it is obligatory to predict the cutting force in order to maintain this value between the allowed limits [6];

- the actual cutting profile is different from the theoretical profile due of tool wear or tool change and also the blank actual profile is different from the theoretical profile, what is more it is individual for each blank. These things determine the need to calibrate the system;

- it is possible to limit the chip width so the process stability is improved;

- it is possible to correct the programmed tool path so that the target trajectory is obtained (see Fig. 1).

In the cutting machining the tool and the blank have

deviations from the theoretical profile. The presented method proposes the determination of these deviations, next being possible to establish adequate trajectories for tool and the determination of feed values in such a way as to obtain the

desired piece profile in the condition of detaching chips with constant section areas, at the same time maintaining the imposed tool-blank contact length and the geometrical roughness [5].

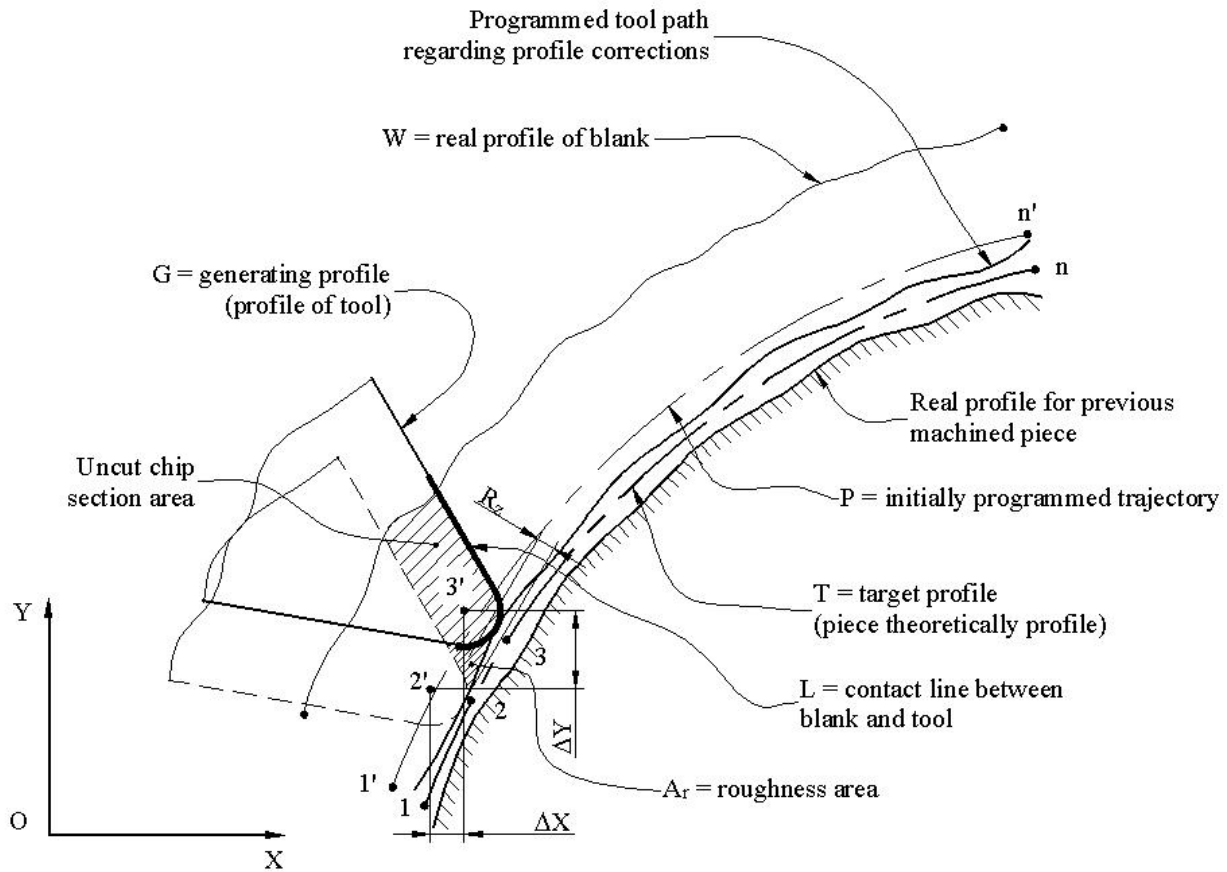

Fig. 1 Piece profile generation

II. PROPOSED METHOD

Specific for this new method are the uses of an extended database which will describe the system behavior.

If we admit as parameters of the *reconfigurable machine tool* model (RMT) the values (see Fig. 1):

A is the uncut chip section area, defined as area included between the blank boundary, the contact line between tool and blank at the current step and the contact line between tool and blank at the previous step [mm^2];

ΔX — the tool displacement increment on X direction [mm];

ΔY — the tool displacement increment on Y direction [mm];
 G — profile of generating tool (known in numerical form, obtained by measuring);

W — real profile of blank (known in numerical form, obtained by measuring);

T — piece theoretically profile (known in analytical form);

P — tool path programmed initially, regardless the correction determinates from the previously machined piece;

L — the contact length between the tool profile and the blank [mm];

R_z — roughness [mm];

A_r — roughness area at each step [mm^2],

so that we can consider that the RMT general model is described by an equation with the form

$$F(A, \Delta X, \Delta Y, G, W, T, L, R_z, A_r) = 0. \quad (1)$$

The practical use of the extended database consists in obtaining a data set of the type

$$\text{dataset} = \{A, \Delta X, \Delta Y, G, W, T, L, R_z, A_r\}. \quad (2)$$

In the classical approach the system identification starts from an experimental database, on which there is applied an identification algorithm and the system model [1], [2] results.

The system identification by using the predictive analysis of the cutting force based on the uncut chip section area proposes to determine a current database that is applied to the model and an extended database is determined.

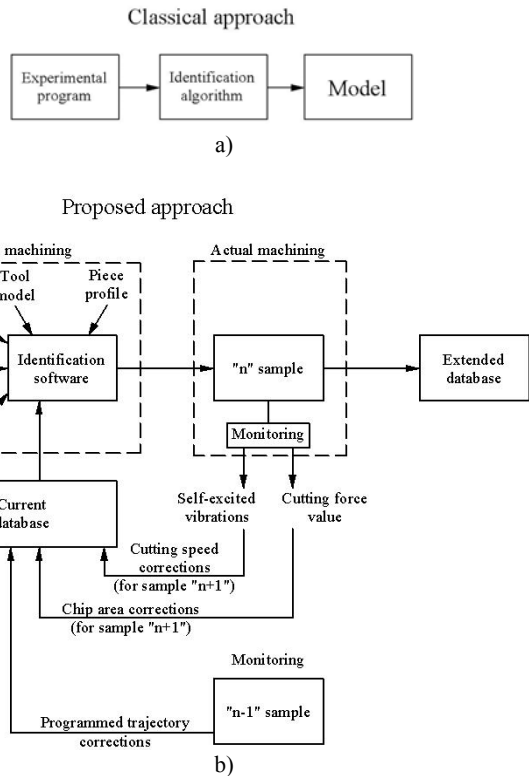

Fig. 2 Identification scheme a) Classical approach b) Proposed approach

First of all the tool and the blank real profile are determined by measurement. There is also established the allowed geometrical roughness and the programmed tool path.

During the machining process the cutting force is monitored and there is verified whether the force value respects the imposed limits.

If, due to certain conditions, the cutting force is smaller than the allowed value then it is possible to increase it, idle to increase the value of the uncut chip section area, for the next piece. On the other hand, if the cutting force is greater than the allowed value, the uncut chip section area will be decreased.

If the self-excited vibrations emerge the cutting speed needs to decrease. By monitoring the vibration, we will be able to determine the tool position where the cutting speed needs to be decreased.

Before each exemplary machining, the previous machined exemplary is measured and the effective roughness and profile are determined.

Each of these parameters will be input data for the next extended database generation.

This database is obtained by virtual machining of each part exemplary.

The cutting force limitation may be made either in the virtual machining stage (in the case of shaping) or in the real machining stage (in the case of continuous cutting). In this last case the chip section area is modified after each piece machining, in order to limit the cutting force for the next piece.

Based on the previous machined piece profile it is possible to correct the programmed trajectory hereby so as to obtain a profile closer to the theoretical profile.

III. THE IDENTIFICATION ALGORITHM

RMT identification based on this new method presumes three phases.

A. Monitoring

The blank and tool profile are numerically determined, by measuring. Based on these profiles the tool and blank models are made using a graphical representation environment [4]. These models are made as regions, on these being possible to apply the commands of the graphical representation environment (INTERSECT and SUBTRACT).

B. Virtual Machining

Being known the target profile (in analytical form) the tool path is determined, displacing the tool model in such a way that it is tangent to the piece model. The successive positions of the tool model insertion point will determine the trajectory and the programmed tool path (in numerical form). Each of these positions will be a calculus stage.

If the profile of a previously machined piece has deviations from the theoretical profile it is possible to correct the programmed tool path in order to decrease these deviations.

At each stage the geometrical roughness is determined and it is compared with the admissible limit, initially established. If the roughness value is greater than the limit, the tool is brought back in the previous position, the displacement increment is decreased and the tool is positioned again.

When there has been obtained an admissible value for the geometrical roughness, the uncut chip section area is determined. Similarly with the previous step this area is compared with the admissible limits, initially established.

When an admissible value for uncut chip area is obtained, the contact length between tool and blank is compared with the admissible limits.

For each case the tool is positioned with values that will not affect the previously determined parameters (roughness and area).

In this way there is determined the tool region insertion point for which all of the three mentioned criteria (R_z , A , L) are satisfied. This point will be regarded as the programmed trajectory point and the model parameters will be saved in the output data file.

The logical scheme of this algorithm is showed in Fig. 3.

A file of dataset on form (2) is obtained, which is the *extended database*.

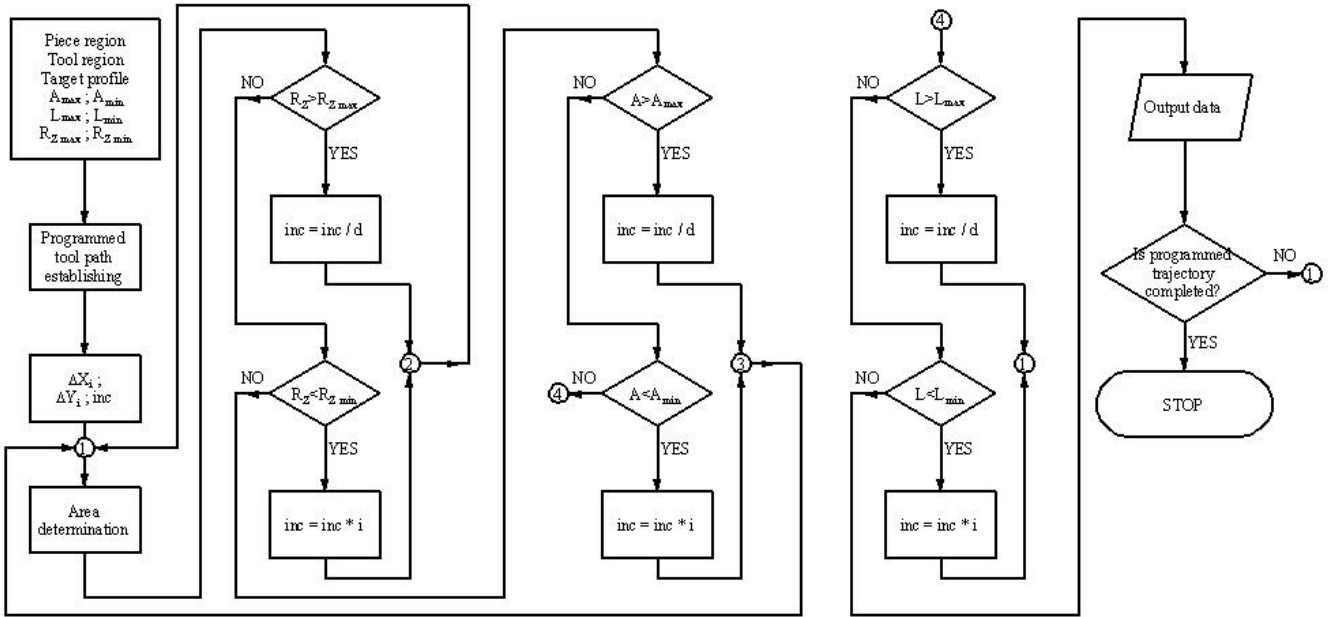

Fig. 3 The logical scheme of the algorithm

We have to consider that each dataset refers to the intervals of the uncut chip section area, so the output file is a data array with three dimensions (see Fig. 4).

A ∈ {A _{nmin} ; A _{nmax} }									
Step	ΔX	ΔY	L	A _r	R _Z	t	Average R _Z	R _Z dispersion	
A ∈ {A _{1min} ; A _{1max} }									
Step	ΔX	ΔY	L	A _r	R _Z	t	Average R _Z	R _Z dispersion	
1	ΔX ₁	ΔY ₁	L ₁	A _{r1}	R _{Z1}	t	Average R _Z	R _Z dispersion	
2	ΔX ₂	ΔY ₂	L ₂	A _{r2}	R _{Z2}				
...									
i	ΔX _i	ΔY _i	L _i	A _{ri}	R _{Zi}				
...									
n	ΔX _n	ΔY _n	L _n	A _{rn}	R _{Zn}				

Fig. 4 Extended database

C. Real Machining

After the obtaining of extended database, the piece is machined and after these, is measured in order to obtain the needed corrections for the next piece.

IV. THE PARAMETER SELECTION

Using machine tools which allow the unevenness variation of feed, the tool is driven along the programmed tool path, with the feed value increment obtained by the extended database.

Obviously, we will obtain an unevenness feed that allows detaching chips with even section area and hence even cutting forces on all machining processes.

More, during the whole process, the contact length between the tool and the blank is evaluated in order to avoid the self-vibration. If, due to constraints, the self-vibration may appear, the cutting speed is decreased in these zones.

This way, not only the feed but also the cutting speed and the cutting depth are scheduled.

The geometrical roughness of the surface is within the initially established limits, from the extended database, being possible to determine the average value and the roughness dispersion.

V. APPLICATION

It was developed the software for the extended database generation in case of cylindrical involute gear machining by rolling.

The tool is a rack-gear cutter with five teeth and the piece has the following characteristics:

- modulus $m=5$ mm;
- piece teeth number $z_f=30$;
- dividing diameter $D_d=150$ mm.

In Fig. 5 there are shown the uncut chip section area variations for two cases, the first when the feed is scheduled based on this method and the second when the feed is constant.

Is obviously that the uncut chip section area has a significant variation when the feedrate is constant.

When the feed is scheduled regarding the uncut chip section area, this is more uniform (see also Table I and II).

In Tables I and II there are presented the coordinates of the

position of the tool and the calculated chip areas for each case.

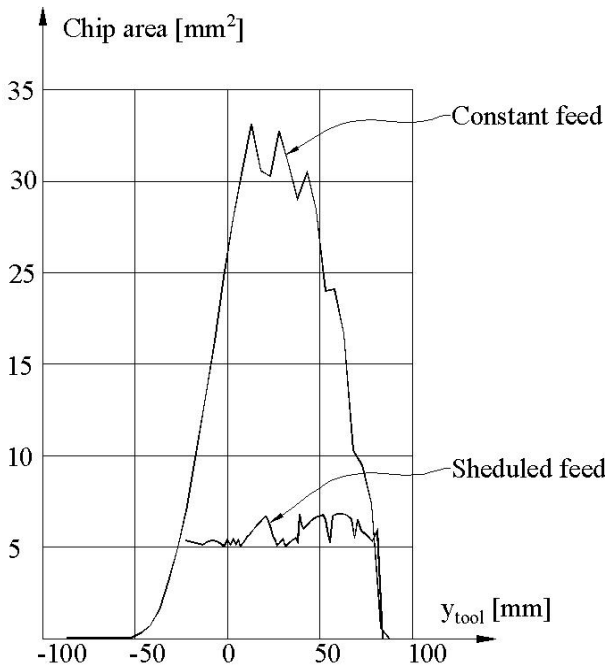

Fig. 5 Uncut chip section area variation

TABLE I
 TOOL POSITION FOR CONSTANT FEED

y [mm]	Chip area [mm ²]
88.0	0.556317
83.0	7.38469
78.0	9.49459
⋮	⋮
3.0	19.75
-2.0	16.2833
-7.0	13.1818
⋮	⋮
-82.0	0.0660639
-87.0	0.0660639

TABLE II
 TOOL POSITION FOR SCHEDULED FEED

y [mm]	Chip area [mm ²]
84.1422	5.92252
81.1948	5.33825
78.2473	5.6861
⋮	⋮
33.1221	5.14407
32.1665	5.05074
31.1154	5.44715
⋮	⋮
-13.4498	5.22788
-17.4416	5.37716
-22.7547	5.02281

VI. CONCLUSIONS

This paper presents a new approach for on-line geometrical identification of the reconfigurable machine tool, using virtual machining.

The RMT is monitored and there is generated an *extended database* that is easier to use as system model in order to make a predictive analysis of the cutting conditions.

The method has some advantages regarding the classical methods, as follows:

- It is possible to predict the cutting force variation in case of complex cutting processes and in case of processes where the cutting is not continuous (generation by rolling with rack-gear tool or with gear-shaped tool);
- The actual tool and blank profiles that are different from the theoretical profile are considered;
- It is possible to predict the chip width and to limit the width or the cutting speed so that the process stability is improved;
- It is possible to correct the programmed tool path so that the piece profile is closer to the theoretical profile;
- Due to the feed scheduling the machining time is reduced so the process productivity is increased.
- The tool load unevenness is decreased so that the endurance is increased.

ACKNOWLEDGMENT

Authors thanks to National Excellence Research Program CEEEX no. 22/2005 of "Dunarea de Jos" University of Galati.

REFERENCES

- B. K. Fussell, R. B. Jerard, J. G. Hemmett, *Robust Feedrate Selection for 3-Axis NC Machining Using Discrete Models* in Journal of Manufacturing Science and Engineering, vol. 123, May 2001, pp. 214-224;
- R. G. Landers, A. G. Ulsoy, *Model-Based Machining Force Control*, in Journal of Dynamic Systems, Measurement and Control, vol. 122, September 2000, pp. 521-527;
- H. U. Lee, D. W. Cho, *An intelligent feedrate scheduling based on virtual machining*, in International Journal of Advanced Manufacturing Technologies, July 2003, pp. 873-882;
- M. Dima, *Contributions at Cutting Scheme Modeling at Rolling Axodes Associated Surfaces Generation*, doctoral thesis, "Dunarea de Jos" University of Galati, Romania, 2006;
- N. Oancea, M. Dima, V. Teodor, *Similitudes Between the Methods used to Study Enveloping Surfaces. I. The Profiles Associated to Rolling Centroids*, in: The Annals of "Dunarea de Jos" University of Galati, Fasc. V, year XIX, ISSN 1221-4566, 2001, pp. 40-45;
- M. Dima, N. Oancea, *Constructive modifications for the energetically improvement of the tooting process*, in: Romanian Journal of Technical Sciences Applied Mechanics, Tome 49, special number 2004, Proceedings of the International Conferences on Manufacturing Systems ICMaS 2004, ISBN 973-27-1102-7, pp. 237-241;
- L. K. Daneshmend, H. A. Pak, *Model Reference Adaptive Control of Feed Force in Turning*, in: ASME J. Dyn. Syst., Meas., Control, 108, No. 3, pp. 215-222;
- K. K. Wang, *Solid Modeling for Optimization Metal Removal of Three-Dimensional NC End Milling*, in: J. Manuf. Syst., 7, No. 1, 1988, pp. 57-65.