

Design of Medical Information Storage System – ECG Signal

A. Rubiano F, N. Olarte and D. Lara

Abstract—This paper presents the design, implementation and results related to the storage system of medical information associated to the ECG (Electrocardiography) signal. The system includes the signal acquisition modules, the preprocessing and signal processing, followed by a module of transmission and reception of the signal, along with the storage and web display system of the medical platform. The tests were initially performed with this signal, with the purpose to include more biosignal under the same system in the future.

Keywords—Acquisition, ECG Signal, Storage, Web Platform

I. INTRODUCTION

CURRENTLY in hospital environments, the need arises to remotely transmit different types of biological signals with the best quality possible, in order to provide an effective diagnosis in the shortest time frame by the specialist, thereby facilitating a better tracking of patients and decreased costs and transfers.

The advancement of technology in biomedical signals field has allowed to review such aspects as device design, analog and digital signal processing, analysis of communication protocols and technologies integration for transmission and subsequent reception. The signal used for this work is the ECG, which has been widely studied and documented by many researchers in bioengineering field.

Although the ECG signal is a biological variable constant over time, it is not possible to directly acquire its electrical potential. To obtain this type of signal it is necessary to use conventional methods, the most important is the electrocardiogram, which consists of 12 leads that are the result of the heart exploration from different levels. This method records the electrical activity of the heart during a heartbeat.

On the other hand, it should be noted that in order to acquire the signal, consider the following parameters: A limited frequency band between 0 Hz and 100 Hz [1], values around millivolts and, finally, is highly susceptible to unwanted noise either by the tissues surrounding the heart, which provide their

Astrid Rubiano is with the Military University “Nueva Granada” Investigation’s Group Director, Bogotá, Colombia (phone: 6500000 Ext 1295; e-mail: astrid.rubiano@unimilitar.edu.co).

Nancy Olarte is with the Military University “Nueva Granada”, Auxiliar researcher, Bogotá, Colombia (phone: 6500000 Ext 1295; e-mail: nancy.olarte@unimilitar.edu.co).

David Lara is with the Military University “Nueva Granada”, Young Researcher, IEEE Member, Bogotá, Colombia (phone: 6500000 Ext 1295; e-mail: david.lara@unimilitar.edu.co).

own potential, the electrical grid, coupled noises from other devices, muscle contractions, breathing and the electrode and the skin contact. [2].

This research paper examined two primary research themes: The ECG signal processing, and implementation of an user authentication system platform that stores patient information.

A. Background

Long before the twentieth century, the ability of the heart as current electrical generator was explored. However, during this century the first bipolar leads standards D1, D2 and D3 were described by Einthoven, assuming that the human body is a good conductor, from this concept it is built an imaginary triangle formed by the root’s members on which sides would be projected electrical forces emanating from the heart muscle [3], as shown in Fig. 1, the other 9 member’s unipolar leads are: VR, VL and VF, and unipolar precordial leads are: V1, V2, V3, V4, V5 and V6.

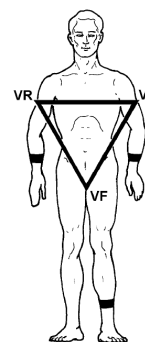

Fig. 1 Einthoven Triangle [3]

Based on the standard bipolar leads, the cardiac ECG wave is generated, which will be described later.

For this signal, it counts with several acquisition systems such as: electronic components implementations that used electrocardiography amplifiers, capable of increasing amplitude levels without altering the shape of the signal [4], devices such as patient simulators and a large databases acquired from a worldwide real patients serving as a template for evaluating algorithms applied to this signal.

Among the worldwide applications developed by monitoring various diseases from the study of the ECG, in 2008 in Mexico, was developed a monitoring device called CARE which has a central control unit in charge of processing the ECG signal. It stores the signals in the SD memory and

then transmitted via GPRS modem [5], as shown in the following block diagram in Fig. 2:

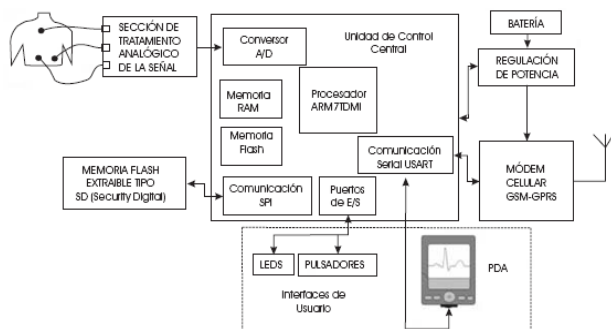

Fig. 2 CARE Monitoring device [5]

Also in Cuba, at the Digital Research Central Institute, developed a system called Cardiofile [6], designed to process the recorded information by a biphasic defibrillator monitor, and then display it on a monitor screen. This system handles a "Location Table," which shows a chronological events list to the users, providing the option to identify which cases remain recorded in memory and select those of interest by date and / or features.

After storage, the biosignal display has been incorporated in many cases on telemedicine for emergency services or in mobile units to help the early diagnosis of various diseases such as myocardial stroke, increasing the possibility of a patient's life time.

II. PROPOSED DESIGN

Given the major platforms that are currently made up of various systems and telemedicine services to users, the project purpose was integrate the reception, display and storage of the ECG signal considering remote access and authentication, the above in order to be diagnosed in time without having to move.

A. ECG Signal

From the bipolar derivations D1, D2 and D3 described above, the cardiac wave is generated, which is composed by the following four stages, as shown in Fig. 3:

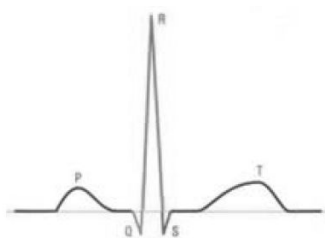

Fig. 3 Heart Wave

The P wave: indicates that the **atria** are stimulated electrically to send blood into the ventricles. Then the QRS complex, which indicates that the ventricles are electrically stimulated to pump out the blood. The ST segment: indicates

the amount of time that occurs from the end of the ventricles contraction to the beginning of the period of rest. The next wave is called the T wave which shows the recovery period of the ventricles. [7].

This type of ECG signal is acquired by an electrocardiogram which is a test that records the electrical activity of the heart during a heartbeat, showing the magnitude and direction of the electrical signals produced by the heart.

The following will describe the implemented methodology for the Design of Medical Information Storage System, for this an ECG signal processing was necessary, followed by the design of a web platform for storing and displaying this sign accompanied by a patients database information, along with security settings.

B. Methodology

The design was developed in phases, which cover all aspects relevant to continue with its implementation. The phases were as follows, as shown in Fig. 4:

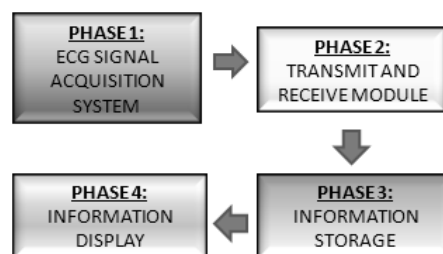

Fig. 4 Methodology

The following describes each of these stages:

1. Acquisition System

For the ECG signal processing, addressing the following modules within the design, as shown in Fig. 5:



Fig. 5 ECG signal Acquisition System.

Acquisition Module: For this module, we used the Fluke PS420 Patient Simulator, shown in Fig. 6, which generates the biomedical signal ECG, applied in our design. Its main features are: it is portable, compact, with a wide range of detailed and accurate simulations not only for the ECG signal and its derivatives, but also of the respiration simulation, blood pressure and temperature.



Fig. 6 Fluke PS420 Patient Simulator [8]

To generate this physiological signal in a real patient, transducers are used or electrodes connected from the chest through shielded leads cables for ECG output. For the PS420 using 3 leads cables connected in the first three outputs (LN, RN and N) of the Patient Simulator and introducing the code for the ECG signal. The outputs of the 3 leads ECG cables going to the Pre-processing module, for improving the signal condition.

Pre-processing Module: This module is responsible for interpreting and conditioning the signal from the patient simulator in order to be processed. It is divided into the following stages, as shown in Fig. 7.



Fig. 7 Pre-Processing Module

To amplify the signal received from the leads ECG cables, was used the AD620 instrumentation amplifier, suitable for use in electrocardiography, also has a high common mode rejection, a supply source between 2.3 V and 18V and between 1 and 1000 gain. Also with this amplifier was used TL084CN JFET operational amplifier for low power consumption and low common mode noise. With the above characteristics, the ECG signal will be visible for further handling or treatment.

The stage of signal filtering is of great importance as it is necessary to remove unwanted noise from sources such as electricity, electrodes and radio frequency. The cascading sequence of filters proposed in the design can be seen below in Fig. 8.



Fig. 8 Signal Filtering

The band pass filter (high pass filter in cascade with low pass filter) limits the frequency spectrum of the ECG signal between 0.5 Hz and 150 Hz. In the Rejection Band filter design, was used a resonant frequency of 60Hz, this filter is the result of using a narrow-band filter cascade circuit that subtracts the original signal from the output of a narrow-band filter.

Signals from the filtering stage are in a range of -1V to 3V, it is necessary to finally design a DC level adjustment circuit, in

order to carry the signal to a voltage range between 0V and 5V, and lower voltage than 0V, may cause significant loss of tension in the reception.

Processing Module: For the development of this module, was chosen the ATmega16 microcontroller, shown in Fig. 9, It is a 40-pin family of ATMEL AVR, due to the following advantages: is in permanently power saving mode so ECG signal is monitored until the graphic module for display so permits, C-based architecture, the speed with instructions is in nanoseconds, high code density, 8-channel A / D converter 10-bit Flash Memory 16 Kbytes 512 bytes of EEPROM and serial programmable USART.



Fig. 9 ATmega16A Microcontroller [9]

To process the data, was implemented a sampling frequency of 350Hz for one of the 8-channel analog / digital available. To generate the frame, it sends a start frame byte, followed by two bytes of the ECG signal of the channel to transmit.

Therefore, this module into our design manages 3 functions: convert from analog to digital information resulting from the ECG signal acquisition module, generates the corresponding bit frames and then sent to the transmit and receive module.

2. Transmit and receive module

To transmit the signal was chosen EIA/TIA RS232 standard, usually use for exchange binary data among DTE (Data Terminal Equipment) and DCE (Data Communication Equipment) in addition to this technology is also considered the recommendation V24, which indicates the data circuits to transfer them in binary mode. As the ATmega16 USART has a serial interface programmable, configuration was performed for the asynchronous communication of data to transmit.

The microcontroller works with TTL levels of 0 to 5V, so it is necessary to have a circuit to converts these voltage levels to 12V and - 12V. Therefore, was use the MAX 232 circuit, which provides excellent performance in setting tension levels between the microcontroller and communication with computers using THE DB9 9-pin male connector, which connect devices to serial port.

Upon completion of the data transmission and reception module was necessary to implement a mechanism for confirmation of this and the display module to avoid a sudden transmission interruption.

3. Storage

The centralized storage information systems have been used in a widely kind of applications and as its name says implement a centralized server that response users request. The storage model is based on a centralized system

management by a powerful [10] object-relational database management system.

Personal and contact information from staff and patients is stored in database by filling out a form; this information is used to link queries and modifications made by physicians to patient registers.

ECG signal acquired along with patients and medical staff information is stored and management centrally in the main research group server helping control and administration process. The ORDBMS¹ implemented is PostgreSQL for stability, robust and be released under BSD license, chosen because of its good performance [11] in web applications that have to response many request simultaneously.

Figure 10 shows the GUI manager called pgAdminIII PostgreSQL, the left part (a) is a tree with all servers and objects contained within each one, for example shows is pick up a table called *datos* from *postgres* database. The browser located in the upper right (b) shows the details of the currently selected object in the tree, in this case the properties tab of your browser permits to view details such as name, OID or table's primary key from *datos*. The lower right side (c) contains a reverse engineered SQL script.

```

SQL pane
-- Table: dato
-- DROP TABLE dato;

CREATE TABLE dato
(
    carnet character varying NOT NULL,
    nombre character varying NOT NULL,
    apellido character varying NOT NULL,
    sexo character varying NOT NULL,
    CONSTRAINT dato_pkey PRIMARY KEY (carnet)
)
    
```

(c)

Fig. 10 PostgreSQL Administration Console

Being a centralized access to information is via authentication to a server based on specific knowledge that is with a user name, password and secret answer to a question

4. Display - GUI

Display, query and storage information is done through a platform designed to work in a web environment in order to ease information access from the place where the user is located, because only one Internet access team and a web browser is needed. For the development of this platform access requirements were evaluated, security, availability and reliability of the information and the data stored on the server must be available where there is an internet connection.

Figure 11 illustrates a web application behavior designed in JSP (Java Server Pages), this is the basis the operation of the platform. As shown, the requests are made in a web browser and sent to the JSP, it processes them and depending on the information requested by the user accesses the database through the JavaBean or respond from the same JSP with the needed information.

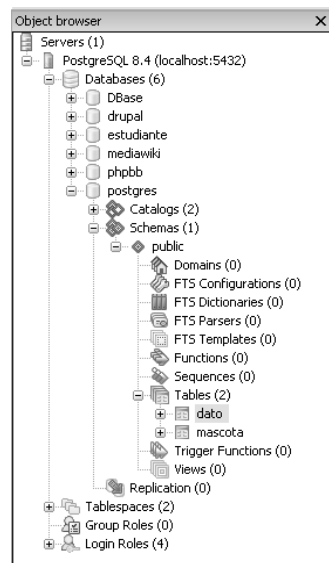

(a)

Property	Value
Name	dato
OID	16484
Owner	postgres
Tablespace	pg_default
ACL	
Primary key	carnet
Rows (estimated)	0
Fill Factor	
Rows (counted)	9
Inherits tables	No
Inherited tables count	0
Has OIDs?	No
System table?	No
Comment	

(b)

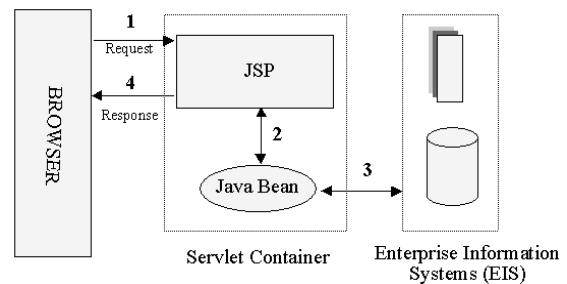

Fig. 11 JSP Operation Scheme²

The server responsible for receiving and responding requests from users carry out authentication recognizing and classifying each one within a previously profile job defined by the system administrator, the platform has two identifiable profile users: operator and medical staff.

- *Operator*: Solely responsible for taking the test, linking it to a patient and stored in the database.
- *Medical staff*: Has access to patient information including diagnostic tests and can perform each one.

¹ Object-Relational Database Management System

² Scheme taken from www.sun.com

IV. CONCLUSION

The platform has an authentication system based on access by using an ID and a Password, then the user must answer a question that allows him to access the platform, this system of authentication does not properly comply with the requirements of international standards but this item is open for future developments and research within the group.

All information transmitted between the user and the server travels encrypted through SSL-based connection.

III. RESULTS

The following are the test results made with the medical information storage system:

A. ECG Acquisition

After ECG signal conditioning through acquisition and filtering from adjustment DC level circuit the result is shown in Figure 12.

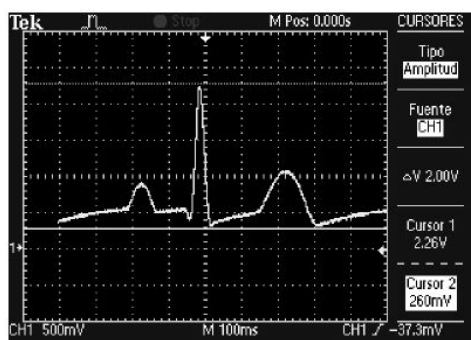

Fig. 12 ECG Acquired Signal after the DC Level Adjustment

Next step consisted on transmit bit frames to platform to be stored and subsequent query by medical staff.

B. Storage and User Interface

Figure 13 shows a database query about basic patient's information made the 20th of July this year, in this case as can be seen there is personal information from a non-real patient and further some ECG register associated.

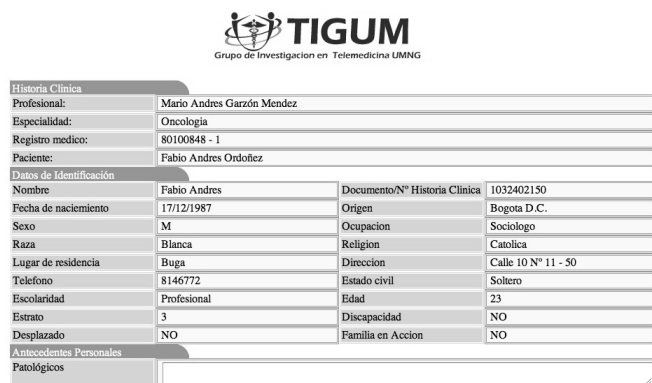

Fig. 13 System GUI

For this design of medical information storage system, initially was used the ECG signal implementation, with the possibility to add more biological signal, such as blood pressure, temperature, and respiration.

Also initially, was used the EIA/TIA RS232 standard, with the possibility to implemented more technologies for transmit and receive data from differents signals acquisition modules.

The telecardiography service can be implemented in small towns and remote areas because of the simply way to be use and lower ratio cost benefit for population. The use of this service under technical conditions described throughout this paper open new research lines such as network security systems into TIGUM³ for future projects.

At the present stage of the project the research group server is hosted in the communications lab of the university because most of the software and acquisition system is still being improvement but many test have been successfully done using the current system.

REFERENCES

- [1] Lemus-Aguilar, "Modular Virtual Instrumentation Handling and Analysis of Electrophysiological Signals" (Paper). 2006, 27 (2), pp. 82-92.
- [2] Andres & Javier, "Analysis and Monitoring of Cardiac Output with Wireless Transmission of Data". (Paper).
- [3] Franco, "The Electrocardiogram leads", (Book Style), pp. 14
- [4] Ballesteros, "Wireless transmission system of ECG signals and temperature for a hospital environment (SIHNO)", (Book Style). 2010, 4 (7), pp. 55-63.
- [5] Depiaggio & Carlos-Monzón, "Bioinstrumentation Amplifier with Digital Input Selection", (Paper), 2002, pp. 21.
- [6] Bustamante, Sáenz, & Amaya, "Detection System, Teleregistration and Monitoring of Cardiac Arrhythmias" (Paper), 2008, 29 (1), pp. 28-40
- [7] Cartaya & Colorado, "Cardiofile: A Multi-event Recorder for use in Defibrillators", (Book Style), 2008, 2, pp. 25-30.
- [8] <http://biomedequip.com/newflukeys420multi-parameterpatientsimulator.aspx>, consulted: Julio 26 2011.
- [9] <http://datasheet.circuitlake.com/microcontroller-avr-atmega16a/>, consulted: Julio 26 2011.
- [10] PostgreSQL Official Documentation, <http://www.postgresql.org/files/documentation/pdf/8.1/postgresql-8.1-A4.pdf>
- [11] PostgreSQL Official Documentation, <http://www.postgresql.org/files/documentation/pdf/8.1/postgresql-8.1-A4.pdf>

³ Telemedicine Investigation Group University Military "Nueva Granada"