

Tunable Photonic Microwave Bandpass Filter Based on EOPM and VPBS

R. Heydari, and M. R. Salehi

Abstract—A tunable photonic microwave bandpass filter with negative coefficient based on an electro-optic phase modulator (EOPM) and a variable polarization beamsplitter (VPBS) is demonstrated. A two-tap microwave bandpass filter with one negative coefficient is presented. The chromatic dispersion and optical coherence are not affected on this filter.

Keywords—Bandpass filter, EOPM, photonic microwave filter, polarization beamsplitter.

I. INTRODUCTION

PHOTONIC processing of microwave and millimeter-wave signals has been an interesting topic for a few years. Radio frequency (RF) signals can be processed in the optical domain with the advantageous features such as broad bandwidth, low loss, light weight, and immunity to electromagnetic interference [1-12].

Recently, it was also reported that a negative tap photonic microwave filter can be implemented based on a Mach-Zehnder modulator and a tunable optical polarizer [11].

In this paper, a tunable photonic microwave bandpass filter with negative coefficient based on an EOPM and a variable polarization beam splitter is proposed. This paper is organized as follows. In Section II, a system configuration of the proposed filter with theoretical analysis is presented. The results are shown in Section III. A brief summary is given in Section IV.

II. FILTER CONFIGURATION

The schematic diagram of the photonic microwave bandpass filter is shown in Fig. 1. The filter consists of a laser diode with an electrical field $E_m(t)$, an EOPM, a microwave modulating signal $V(t)$, a polarization-maintaining (PM) circulator, a quarter-wave plate (QWP), a variable time delay line (VTDL), three-ports polarization beamsplitter (PBS), two uniform fiber Bragg gratings (FBG), and a photodetector (PD).

In this system, a linearly polarized light emitted from a laser diode is modulated by an RF signal at the phase modulator.

The RF signal is generated by a vector network analyzer. The output of the EOPM, which has a Hi-Bi pigtail, is launched into a QWP via port 1 and port 2 of the PM circulator. Then, the phase modulated lightwave is split equally into two orthogonal polarizations by properly rotating the QWP at port 1 of the VPBS. The VPBS has also Hi-Bi pigtails at its ports. One of the orthogonal polarizations at output port 2 of the VPBS, goes through a VTDL with Hi-Bi pigtails and a fiber of length L_1 , and then reflected by a uniform FBG. The other one at output port 3 of the VPBS, passes through a fiber of length L_2 and then reflected by a uniform FBG. Finally, the two orthogonal optical signals are combined at the VPBS with interference and directed to the output Port 3 of the PM circulator and then detected by a photodetector.

With small-signal assumption, the phase-modulated optical field $E_{PM}(t)$ can be expressed as [10]:

$$E_{PM}(t) \approx E_o \left\{ J_0(\beta) \cos \omega_o t + J_1(\beta) \cos \left[(\omega_o + \omega_m) t + \frac{\pi}{2} \right] + J_1(\beta) \cos \left[(\omega_o - \omega_m) t + \frac{\pi}{2} \right] \right\} \quad (1)$$

where E_o and ω_o are the amplitude and angular frequency of the optical carrier, respectively. $J_n(\beta)$ is the Bessel function of the first kind of order n with argument of β , and $\beta = V_m \cdot \pi / V_\pi$ is related to the phase modulation depth, where V_π is the half-voltage of the optical phase modulator, V_m and ω_m are the amplitude and angular frequency of the microwave modulating signal, respectively.

The two orthogonal optical signals after combination at the VPBS have a same polarization. Therefore, the final optical signal at port 3 of the PM circulator can be written as:

$$E_{out}(t) = E_2(t) + E_3(t) \quad (2)$$

M.R. Salehi is with Shiraz University of Technology, Shiraz, Iran (corresponding author to provide phone: 98-711-7353500; fax: 98-711-7354514; e-mail: salehi@sutech.ac.ir).

R. Heydari received the M.Sc. degree in electrical engineering from Shiraz University of Technology, Shiraz, Iran (e-mail: r.heydari@sutech.ac.ir).

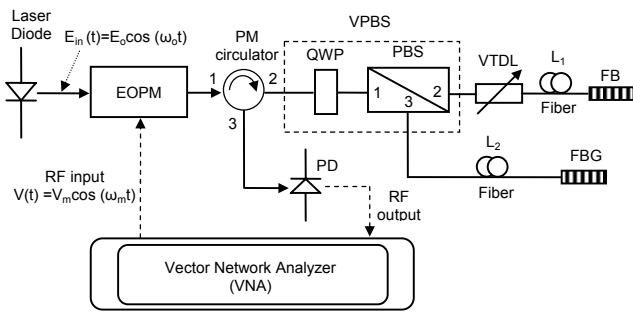

Fig. 1 Block diagram of the microwave bandpass filter

By assuming the responsivity of the photodetector to be r , the recovered RF signal at the output of the PD is given by:

$$I_{RF}(t) = \frac{rE_o^2 J_o(\beta) J_1(\beta)}{2} \times \left\{ \begin{aligned} & -\cos(2\omega_o \Delta\tau_d + (2\varphi_o - \theta_1 - \theta_2)) \\ & \times \cos[\omega_m t - (\theta_1 - \theta_2)] \\ & + \cos(2\omega_o \Delta\tau_d - (2\theta_o - \varphi_1 - \varphi_2)) \\ & \times \cos[\omega_m(t - 2\Delta\tau_d) - (\varphi_1 - \varphi_2)] \end{aligned} \right\} \quad (3)$$

In equation (3), the dc and the second-order harmonics are omitted because of the limited bandwidth of the photodetector. The phase delay (θ and φ) of a single optical frequency that is introduced by a single-mode fiber is equal to $z\beta(\omega)$, where $\beta(\omega)$ is the propagation constant of the optical carrier and z is the distance traveled.

The amplitude of the filter transfer function in ω_m can be written as:

$$|H(\omega_m)| = \left| \frac{rE_o^2 J_o(\beta) J_1(\beta)}{2} \cos[2\omega_o \Delta\tau_d + 2\beta_o(L_1 - L_2)] \right| \times |1 - \exp[-j\Delta\tau \omega_m]| \quad (4)$$

where $\beta_o = \beta(\omega_o)$, $\Delta\tau = 2(\Delta\tau_o + \Delta\tau_d)$ and $\Delta\tau_o = \beta_1(L_1 - L_2)$ is the fixed time delay. Since the lengths of L_1 and L_2 are only several meters, their chromatic dispersion values are near to zero, so we can neglect the second and higher-order derivatives of β .

The free spectral range (FSR) of the filter can be given as:

$$FSR = \frac{1}{\Delta\tau} = \frac{1}{2(\Delta\tau_o + \Delta\tau_d)} \quad (5)$$

By tuning the value of the time delay $\Delta\tau_d$, the FSR can be changed. Thus, the filter is tunable.

III. RESULTS

The normalized frequency responses of the photonic microwave bandpass filter for different parameters are shown in Figs. 2-4. For a typical value of $n_g = 1.5$, the parameter β_1 is equal to 5000 ps/m.

In Fig. 2, $\Delta\tau_d$ is zero and the length difference between L_1 and L_2 is about 1 m. So the fixed time delay value $2\Delta\tau_o$ is about 10000 ps and gives an FSR of 100 MHz. In this case, when $\Delta\tau_d$ is changed from 0 to 250 ps, the time delay $\Delta\tau$ varies from 10000 to 10500 ps, and FSR can be tuned continuously from 95.24 to 100 MHz.

In Fig. 3, $\Delta\tau_d = 0$ and $L_1 - L_2 = 0.5$ m. The fixed time delay value $2\Delta\tau_o$ is about 5000 ps and gives an FSR of 200 MHz. In this case, when $\Delta\tau_d$ is changed from 0 to 250 ps, the time delay $\Delta\tau$ varies from 5000 to 5500 ps, and FSR can be tuned continuously from 181.8 to 200 MHz.

In Fig. 4, $\Delta\tau_d = 0$ and $L_1 - L_2 = 1.6$ cm. The time delay $\Delta\tau$ is about 160 ps and FSR is equal to 6.25 GHz.

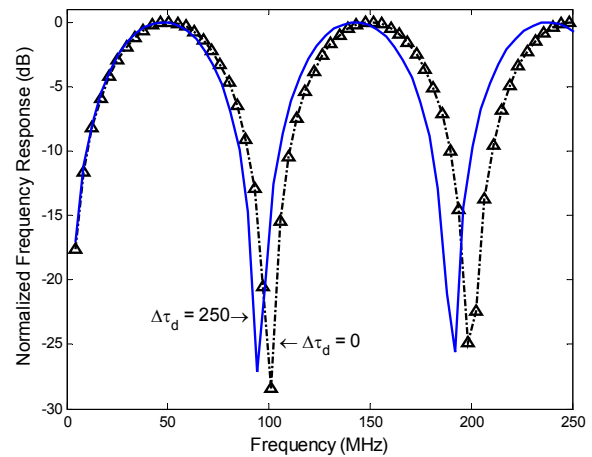

Fig. 2 Frequency responses of the two-tap microwave bandpass filter for $L_1 - L_2 = 1$ m, $\Delta\tau_d = 250$ ps, FSR=95.24 MHz; $\Delta\tau_d = 0$ ps, FSR=100 MHz

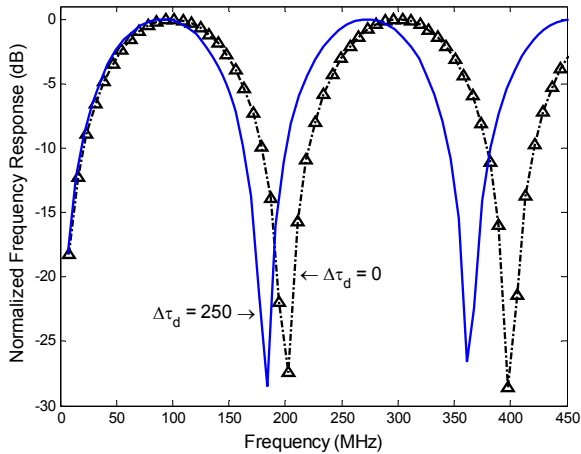

Fig. 3 Frequency responses of the two-tap microwave bandpass filter for $L_1-L_2=0.5$ m, $\Delta\tau_d=250$ ps, FSR=181.81 MHz; $\Delta\tau_d=0$ ps, FSR=200 MHz

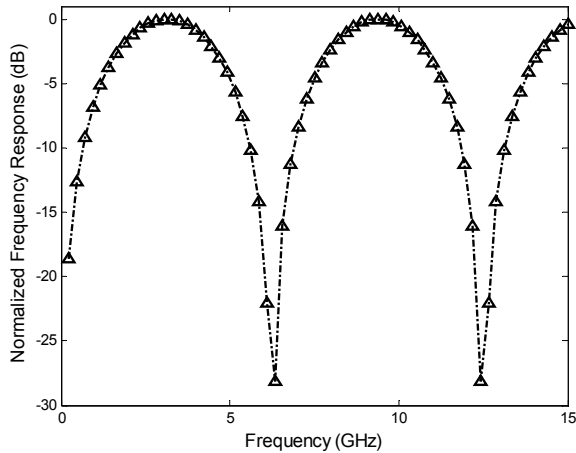

Fig. 4 Frequency responses of the two-tap microwave bandpass filter for $L_1-L_2=1.6$ cm, $\Delta\tau_d=0$ ps, FSR=6.25 GHz

IV. CONCLUSION

In this paper, a tunable photonic microwave bandpass filter with negative coefficient using an optical phase modulator and a variable polarization beamsplitter was investigated. The configuration can yield small or large FSR values by using two fibers with a short length difference. By adjusting the variable time delay line, the FSR of the bandpass filter can be continuously tuned. This filter is free from the problems of chromatic dispersion and optical coherence. A photonic microwave filter with coefficients of (1,-1) was obtained.

REFERENCES

[1] J. Capmany, B. Ortega, and D. Pastor, "A tutorial on microwave photonic filters," *J. Lightw. Technol.*, vol. 24, no. 1, pp. 201–229, Jan. 2006.
 [2] R. A. Minasian, "Photonic signal processing of microwave signals," *IEEE Trans. Microw. Theory Tech.*, vol. 54, no. 2, pp. 832–846, Feb. 2006.
 [3] S. Sales, J. Capmany, J. Marti, and D. Pastor, "Experimental demonstration of fiber-optic delay line filters with negative coefficients," *Electron. Lett.*, vol. 31, no. 13, pp. 1095–1096, Jul. 1995.

[4] F. Coppinger, S. Yegnanarayanan, P. D. Trinh, and B. Jalali, "All-optical RF filter using amplitude inversion in a semiconductor optical amplifier," *IEEE Trans. Microw. Theory Tech.*, vol. 45, no. 8, pp. 1473–1477, Aug. 1997.
 [5] X. Wang and K. T. Chan, "Tunable all-optical incoherent bipolar delay-line filter using injection-locked Fabry-Pérot laser and fiber Bragg gratings," *Electron. Lett.*, vol. 36, no. 24, pp. 2001–2002, Dec. 2000.
 [6] S. Li, K. S. Chiang, W. A. Gambling, Y. Liu, L. Zhang, and I. Bennion, "A novel tunable all-optical incoherent negative-tap fiber-optic transversal filter based on a DFB laser diode and fiber Bragg gratings," *IEEE Photon. Technol. Lett.*, vol. 12, no. 9, pp. 1207–1209, Sep. 2000.
 [7] E. H.W. Chan and R. A. Minasian, "Novel all-optical RF notch filters with equivalent negative tap response," *IEEE Photon. Technol. Lett.*, vol. 16, no. 5, pp. 1370–1372, May 2004.
 [8] J. Wang, F. Zeng, and J. P. Yao, "All-optical microwave bandpass filters implemented in a radio-over-fiber link," *IEEE Photon. Technol. Lett.*, vol. 17, no. 8, pp. 1737–1739, Aug. 2005.
 [9] G. Ning, P. Shum, S. Aditya, Linghao Cheng, and H. Dong, "Bandpass multitap microwave photonic filter with a round-trip configuration," *Microwave and Optical Technology Letters.*, vol. 50, no. 5, pp. 1181–1184, May 2008.
 [10] F. Zeng and J. P. Yao, "Investigation of phase modulator based all-optical bandpass filter," *J. Lightw. Technol.*, vol. 23, no. 4, pp. 1721–1728, Apr. 2005.
 [11] Q. Wang, J. P. Yao, and J. D. Bull, "Negative tap photonic microwave filter based on a Mach-Zehnder modulator and a tunable optical polarizer," *IEEE Photonics Technology Letters*, vol. 19, no. 21, pp. 1750–1752, Nov. 2007.
 [12] G. Ning, P. Shum, "Switchable and tunable microwave photonic filter using a variable polarization beamsplitter in a Sagnac interferometer," *J. Opt. A: Pure Appl. Opt.*, vol. 9, no. 12, pp. 1136–1139, Dec. 2007.