

Selection and Exergy Analysis of Fuel Cell System to Meet all Energy Needs of Residential Buildings

G.R. Ashari, N.Hedayat, S. Shalhaf and E.Hajidavalloo

Abstract—In this paper a polymer electrolyte membrane (PEM) fuel cell power system including burner, steam reformer, heat exchanger and water heater has been considered to meet the electrical, heating, cooling and domestic hot water loads of residential building which in Tehran. The system uses natural gas as fuel and works in CHP mode. Design and operating conditions of a PEM fuel cell system is considered in this study. The energy requirements of residential building and the number of fuel cell stacks to meet them have been estimated. The method involved exergy analysis and entropy generation through the months of the year. Results show that all the energy needs of the building can be met with 12 fuel cell stacks at a nominal capacity of 8.5 kW. Exergy analysis of the CHP system shows that the increase in the ambient air temperature from 1°C to 40°C, will have an increase of entropy generation by 5.73%. Maximum entropy generates for 15 hour in 15th of June and 15th of July is estimated to amount at 12624 (kW/K). Entropy generation of this system through a year is estimated to amount to 1004.54 GJ/k.year.

Keywords—CHP mode, entropy, exergy, no of fuel cell stacks.

I. INTRODUCTION

IN the last decade, problems related to energy factors, ecological aspects (climatic change), electric demand (significant growth) and financial/regulatory restrictions of wholesale markets have increased globally. These difficulties, far from finding effective solutions, are continuously increasing, which suggests the need of technological alternatives to assure their solution. One of these technological alternatives is named distributed generation (DG). Distributed generation also called on-site generation, generates energy in place of consumption. Currently industrial countries generate most of their energy needs by large centralized power plants. These plants negatively affect environment. In addition to higher overall energy conversion efficiency and lower environmental pollutions, these technologies provide other advantages such as elimination of power distribution lines, lower overall system cost, and higher security [1]. Distributed generation (DG) technologies are divided into two main objects: 1) Renewable, 2) Non-Renewable technologies. Cogeneration or combined heat and power (CHP) systems play an important role in the field of Non-Renewable sources. We use of cogeneration system when heat and power are required. All power plants emit a certain amount of heat during electricity generation.

G.R. Ashari, Researcher , Faculty of engineering , Islamic Azad University, Dezful Branch, Dezful, Iran.

N.Hedayat, Faculty of eng, Islamic Azad University, Dezful Branch, Iran.

S. Shalhaf, Faculty of eng , Islamic Azad University, Dezful Branch, Iran.

E.Hajidavalloo, Associate Professor of Mechanical Engineering Department, Shahid Chamran University, Ahvaz, Iran

In the most heat engines, a bit more than half is lost as excess heat. By capturing the excess heat cogeneration systems uses waste heat produced during electricity generation, potentially reaching an efficiency of up to 90%, compared with 55% for the best conventional plants. This means that less fuel needs to be consumed to produce the same amount of useful energy. Thus, a more economical method is obtained compared to the systems where electricity and heat are separately produced [2].

Among cogeneration systems which are used in residential building, Fuel cell systems play an important part because of their cost effectiveness and high efficiency [1],[2]. The use of fuel cells, micro gas turbines and internal combustion engines for OS-CHP, or on-site combined heat and power production in residential building, has been studied by several researchers [3]–[17].

The present research considered the design and operating conditions of a CHP fuel cell system emphasis on entropy production. A designed system including fuel cell stacks, burner, steam reformer, heat exchanger, battery and water heater to meet the electrical power of the building as well as part of the power required by heat pump and mechanical refrigerator needed for heating, cooling and DHW systems is considered. The remaining part of the power for heat pump and mechanical refrigerator is provided by the exhaust gases. The fuel of burner and reformer is natural gas. The configuration of this system is shown in Fig. 1.

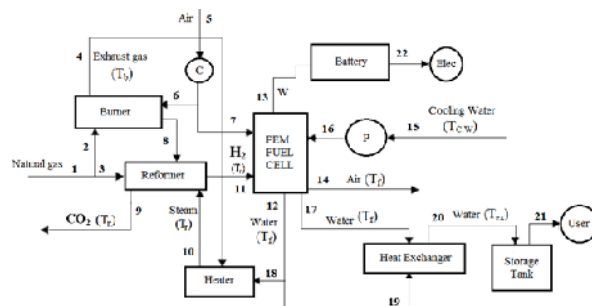

Fig. 1 Configuration of CHP fuel cell system

Natural gas is fed through line (1) to burner and reformer. In burner, natural gas is reacted with air and heat which is generated is used to meet energy needs of reformer. In reformer, natural gas is reacted with produced steam in heater. Produced hydrogen (H_2) by reformer, is fed to PEM fuel cell (line 11). This hydrogen is reacted with air (line 7), to produce electrical power and hot water. Remaining part of air, is discharged to atmosphere. For cooling of fuel cell, water is

pumped to fuel cell (line 16), which is warmed up and fed to heat exchanger. In heat exchanger, this water is mixed with a part of hot water which produced in PEM (line 19) and is fed to storage tank through. Remaining part of produced water by PEM fuel cell, change to steam in heater, and is used in reformer.

II. ESTIMATION OF ELECTRICAL, HEATING, COOLING AND DOMESTIC HOT WATER ENERGY NEEDS OF RESIDENTIAL BUILDINGS

The building considered in this study is a 10-story residential building with a total of 40 units, each with a floor area of 200 m². The building has a height of 30 m, a length (in east-west direction) of 40 m, and a width of 20 m (in north-south direction). The window areas are 30% of the areas of south and north walls and 20% of the areas of east and west walls of the building. The external and internal walls are 22 and 12 cm thick, respectively, all made of brick with gypsum plaster on the interior walls. The roof is also 22 cm thick, made of brick and roofing materials. No thermal insulation is employed in the walls or the roof of the building. To calculate the electrical, heating and cooling loads of residential building located in Tehran, it was assumed that the 15th day of each month represented all days of that month. Fig. 2 shows the ambient air temperatures for Tehran, during all the months of year [3]. It is shown that most temperatures occur at 3 P.M every month. Also the temperature of Tehran in the July is highest.

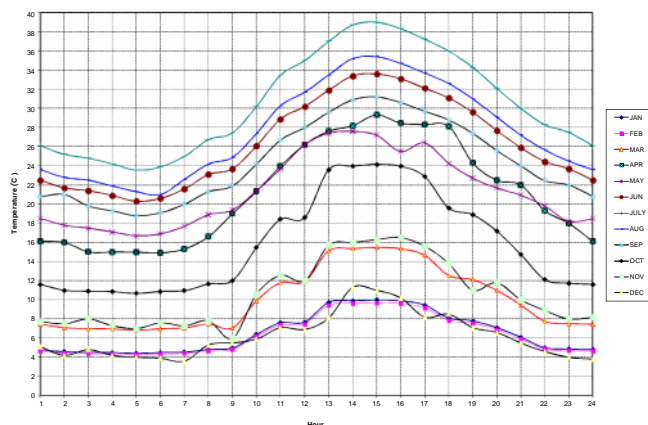

Fig. 2 Ambient air temperatures for Tehran during all the months of year

Fig. 3 shows the total electrical power requirement of the residential building in a 24-h period in July 15. It should be mentioned that Fig. 3 does not include the electrical power and energy needed to operate the electrical motors used for the central heating and cooling systems of the building [3]. Fig. 4 shows the heating and cooling loads of the building in kW, which is located in Tehran, on January 15, April 15 and July 15, respectively. The peak demands of electricity, DHW, heating and cooling are 32.96 kW, 0.926 kW, 1590 kW and 2028 kW respectively.

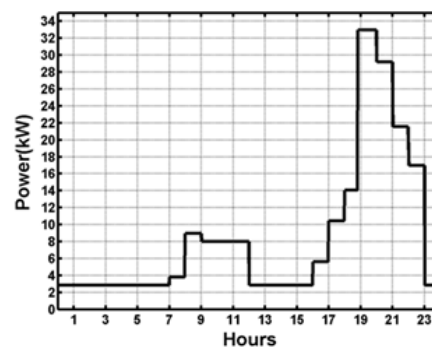

Fig. 3 Total electrical power requirement of the residential building in a 24-h period, estimated for July

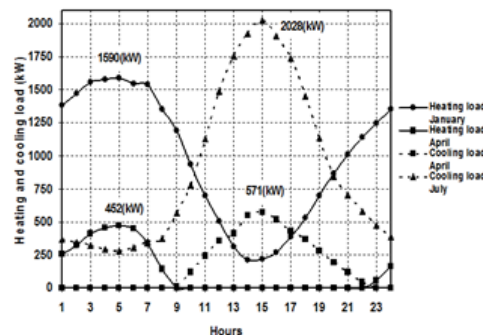

Fig. 4 Heating and cooling loads of the building, estimated on January, April and July

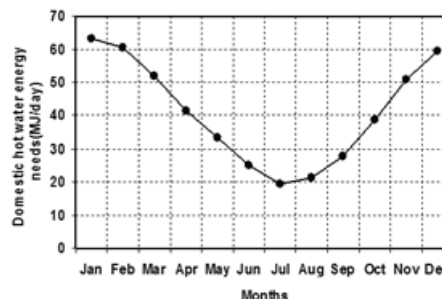

Fig. 5 Domestic hot water energy needs of the residential building

III. ESTIMATION OF NUMBER OF FUEL CELL STACKS NEEDED FOR BUILDINGS LOCATED IN TEHRAN

For better evaluation of the system, the simulation program is developed by FORTRAN language to model consists of the fuel cell stack, burner, steam reformer, water heater and heat exchangers. The fuel cell stack with a nominal power of 8.4 kW is considered here, employing natural gas as fuel.

It can be seen from Figures 3-5 that the maximum electrical power requirement is 32.96 kW, occurring between the hours of 7 and 8 p.m. in July, maximum heating load is 1590 kW, occurring at 5 a.m. in January, the maximum cooling load is 2028 kW, occurring at 3 p.m. in July, and the maximum domestic hot water energy requirement is 0.926 kW, occurring between 5 a.m. and 11 p.m. in January. A method to meet the energy needs of the residential building under consideration is to employ a number of fuel cell stacks to produce electricity to meet the electrical energy needs of the building, and to meet

part of the heating and cooling energy needs through a heat pump. We can use the following equation to determine the number of fuel cell stacks needed for cool operation that heating is to be needed [3].

$$n(\dot{W}_p - \dot{W}_n) \beta_{hp} + n\dot{Q}_{ex,g} \alpha - \dot{Q}_{DHW} = \dot{Q}_{heating} \quad (1)$$

Where n is the number of identical fuel cell stacks employed, \dot{W}_p is the electrical power produced by each fuel cell stack, \dot{W}_n is the electrical power need, β_{hp} is the coefficient of performance (COP) of the heat pump employed, $\dot{Q}_{ex,g}$ is the energy in the exhaust gases, α is the effectiveness of heat exchanger to utilize the energy to produce hot water or steam for heating, \dot{Q}_{DHW} is the DHW energy needs, and $\dot{Q}_{heating}$ is the heating energy needs of the building. The unit of \dot{W}_p , \dot{W}_n , $\dot{Q}_{ex,g}$, \dot{Q}_{DHW} and $\dot{Q}_{heating}$ is kW. All these energy terms are functions of time. For summer operation, or when cooling is needed, we can use the following equation [3]:

$$n(\dot{W}_p - \dot{W}_n) \beta_{ref} + (n\dot{Q}_{ex,g} \alpha - \dot{Q}_{DHW}) \beta_{abs} = \dot{Q}_{cooling} \quad (2)$$

Where β_{ref} is the COP of the refrigerator, operating in the refrigeration mode, β_{abs} is the COP of the employed absorption refrigerator to produce chilled water for cooling, and $\dot{Q}_{cooling}$ is the cooling load of the building in kW. Refer to (1) and (2), we assume the following properties for the system employed:

$$\beta_{abs} = 3, \beta_{ref} = 2.5, \beta_{abs} = 0.7, \alpha = 0.8$$

IV. EXERGY ANALYSIS

The exergy of a system is the maximum useful possible work during a process that brings the system to the equilibrium with a heat reservoir. In the other hand, exergy analysis is a method that uses the conservation of mass and conservation of energy principles together with the second law of thermodynamics for the analysis, design and optimization of systems [18],[19]. Today there is a much stronger emphasis on exergy aspects of systems and processes. In this paper we considered system analysis and thermodynamic optimization. As a result of recent advances, exergy has gone beyond thermodynamics and become a new distinct discipline because of its interdisciplinary character as the confluence of energy, environment and sustainable development.

In this study, the two components of exergy which are kinetic exergy and potential exergy are assumed to be negligible. But physical and chemical exergy are important parts of exergy in thermodynamic analysis. Applying the first and the second law of thermodynamics, the following exergy balance is obtained [18]:

$$e_{ph} = C_p T_o \left[\frac{T}{T_o} - 1 - \ln \left(\frac{T}{T_o} \right) \right] + RT_o \ln \frac{P}{P_o} \quad (3)$$

$$e_{ch} = \sum_{i=1}^n x_i e_{ch,i} + RT_o \sum_{i=1}^n x_i \ln(x_i) \quad (4)$$

$$e_t = e_{ph} + e_{ch} \quad (5)$$

Where e_{ph} , e_{ch} , and e_t , are physical exergy, chemical exergy and total exergy, respectively (kJ/kg). Also T is temperature (K), P is pressure (kPa), R is gas constant (kJ/kg.K) and x_i is mole fraction of mixture.

And total entropy generation rate of the whole system is as follow [18]:

$$\dot{S}_{gen} = \frac{1}{T_o} \left[\sum_{in} \dot{m} e_t - \sum_{out} \dot{m} e_t - \dot{W}_{net} \right] \quad (6)$$

Where \dot{S}_{gen} is total entropy generation rate of system in kW/K.

V. RESULTS AND DISCUSION

Depending on the energy needs throughout the year, the number of fuel cell stacks which can operate to meet the electrical and thermal energy needs of the buildings is evaluated. Table 1 and table 2 show the number of fuel cell stacks which should be operated at different hours in the 15th of each month.

Results showed that by increasing the ambient air temperature, the temperature of burner increases and heat rate of burner decreases. This reduction causes an increase in the mass flow rate of fuel and the entropy generation. Fig. 6 shows variation of entropy generation with respect to ambient air temperature in one unit of CHP fuel cell stack. As can be observed, when the ambient air temperature increases from 1°C to 40°C, the entropy generation in the system increases from 1.36 (kW/K) to 1.438 (kW/K).

TABLE I
 NUMBER OF FUEL CELL STACKS WHICH SHOULD BE OPERATED AT DIFFERENT HOURS OF THE 15TH EACH MONTH (JANUARY – JUNE)

hour	Jan	Feb	Mar	Apr	May	Jun
2	7	6	4	2	1	2
4	7	7	4	2	1	2
6	7	7	4	2	1	2
8	6	6	3	1	1	2
10	4	4	1	1	3	4
12	3	2	1	2	5	6
14	1	1	2	3	7	9
15	1	1	2	4	7	10
16	1	1	2	3	6	9
18	3	2	1	3	5	6
20	4	4	1	2	3	5
22	6	5	2	1	2	3
24	6	6	3	1	1	2

TABLE II
 NUMBER OF FUEL CELL STACKS WHICH SHOULD BE OPERATED AT DIFFERENT
 HOURS OF THE 15TH EACH MONTH (JULY – DECEMBER)

hour	July	Aug	Sep	Oct	Nov	Dec
2	2	2	2	1	3	6
4	2	2	1	1	4	6
6	2	2	1	1	4	6
8	3	3	2	1	3	5
10	5	5	3	2	1	4
12	9	9	6	3	1	1
14	11	11	8	4	2	1
15	12	12	8	3	2	1
16	11	11	8	4	2	1
18	9	9	6	3	2	2
20	6	6	4	2	1	3
22	4	4	3	2	2	4
24	3	2	2	1	2	5

Entropy generation from fuel cell stacks which operate in the residential building to meet the electrical, heating and cooling loads during the hours of each month is shown in table 3 and table 4.

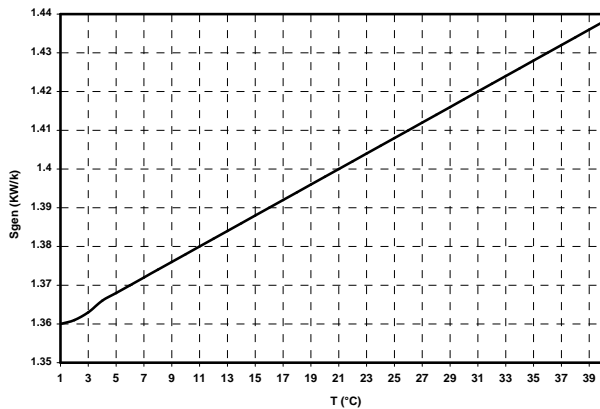

Fig. 6 variation of entropy generation with respect air temperature in one unit of CHP fuel cell stack

TABLE III
 ENTROPY GENERATION FROM FUEL CELL STACKS WHICH OPERATE IN THE
 RESIDENTIAL BUILDING IN KW/K (JANUARY-JUNE)

hour	Jan	Feb	Mar	Apr	May	Jun
2	6.979	5.987	4.007	2.03	1.018	2.059
4	6.983	6.983	4.005	2.027	1.016	2.055
6	6.983	6.983	4.003	2.026	1.016	2.054
8	5.988	5.988	3.003	1.016	1.02	3.095
10	4.001	4.001	1.003	1.023	3.07	5.188
12	3.006	2.004	1.003	2.062	4.155	9.408
14	1.005	1.005	2.028	3.102	7.233	11.567
15	1.005	1.005	2.028	4.144	7.229	12.624
16	1.005	1.005	2.028	3.104	6.179	11.56
18	3.008	2.005	1.003	3.102	5.127	9.424
20	4.005	4.005	1.003	2.05	3.071	6.244
22	5.99	4.992	2.003	1.02	2.042	4.137
24	5.988	5.988	3.003	1.0153	1.019	3.092

From table 3 and table 4, it can be concluded that the

Results further showed that the maximum entropy generation at 15 hour in 15 June and 15 July amounts to 12624 (kW/K), when maximum number of fuel cell stacks (12) are operated. In this time air temperature is equal to 39°C. results also shows that the minimum entropy generation at 12 hour in 15 December, when 1 fuel cell stack operates, amounts to 1.001 (kW/K).

TABLE IV
 ENTROPY GENERATION FROM FUEL CELL STACKS WHICH OPERATE IN THE
 RESIDENTIAL BUILDING IN KW/K (JULY-DECEMBER)

hour	July	Aug	Sep	Oct	Nov	Dec
2	2.059	2.051	2.045	1.007	3.007	5.984
4	2.055	2.048	1.007	1.007	4.008	5.984
6	2.054	2.045	1.005	1.007	4.009	5.981
8	3.095	3.083	2.046	1.008	3.008	4.995
10	5.188	5.165	3.083	2.028	1.005	4.556
12	9.408	9.36	6.204	3.057	1.003	1.001
14	11.567	11.503	8.305	4.11	2.03	1.007
15	12.624	12.552	8.313	3.083	2.031	1.007
16	11.56	11.494	8.293	4.11	2.031	1.006
18	9.424	9.373	6.212	3.062	2.023	2.007
20	6.244	6.214	4.12	2.033	1.006	3.003
22	4.137	4.121	3.075	2.018	2.004	3.992
24	3.092	2.053	2.045	1.008	2	4.984

VI. CONCLUSION

In this paper a polymer electrolyte membrane (PEM) fuel cell power system including burner, steam reformer, heat exchanger and water heater for domestic application has been considered to meet the electrical, domestic hot water, heating and cooling loads of residential building in Tehran. The peak demands of electricity, DHW, heating and cooling are 32.96 kW, 0.926 kW, 1590 kW and 2028 kW respectively. With these measures, 12 CHP fuel cell units with 8.4 kW nominal power could meet all the electrical, DHW, heating and cooling requirements of the building. Exergy analysis of this CHP system suggests that the increase in the ambient air temperature from 1°C to 40°C, will have a corresponding increase in the entropy generation by 5.73%. It was found that the maximum entropy generation at 15 hour in 15 June and 15 July amounts to 12624 (kW/K). Total entropy generation of the system throughout the year is equal to 1004.54 GJ/k. year.

REFERENCES

- [1] M.A. Rosen, N.M. Lee, and I. Dincer, "Efficiency analysis of a cogeneration and district energy system", *Applied Thermal Engineering*, vol. 25, pp. 147–159, 2005.
- [2] J.L. Silveira, A.C.S. Walter, C.A. Luengo, "A case study of compact cogeneration using various fuels", *Fuel*, vol. 76, pp. 447-451, 1997.
- [3] M.A. Ehyaei, M.N. Bahadori, "Selection of micro turbines to meet electrical and thermal energy needs of residential buildings in Iran", *Energy & Buildings*, vol. 39, pp. 1227–1234, 2006.
- [4] M.A. Ehyaei, A. Mozafari, "Energy, economic and environmental (3E) analysis of a micro gas turbine employed for on-site combined heat and power production", *Energy and Buildings*, vol.42, pp. 259–264, 2010.

- [5] M.H. Saidi, M.A. Ehyaei, A. Abbasi, "Optimization of a combined heat and power PEFC by exergy analysis", *Journal of Power Sources*, vol. 143, pp. 179–184, 2005.
- [6] M.H. Saidi, M.A. Ehyaei, A. Abbasi, "Exergetic optimization of a PEM fuel cell for domestic hot water heater", *ASME journal of fuel cell technology* 2, pp. 284-289, 2005.
- [7] C.J. Renedo, A. Ortiz, M. Monana, D. Silio, S. Perez, "Study of different cogeneration alternatives for Spanish hospital center", *Energy and Buildings*, vol. 38, pp. 484–490, 2006.
- [8] K.H. Khan, M.G. Rasul, M.M.K. Khan "Energy conservation in buildings: cogeneration and cogeneration coupled with thermal energy storage", *Applied Energy*, vol. 7, pp. 15–34, 2004.
- [9] M. Dentice, D. Accadia, M. Sasso, "Micro-combined heat and power in residential and light commercial applications" *Applied Thermal Engineering*, vol. 23, pp. 1247-1259, 2003.
- [10] J.L. Miguez, S. Murillo, J. Porteiro J, "Feasibility of a new domestic CHP tri generation with heat pump: I. Design development", *Applied Thermal Engineering*, vol. 24, pp. 1409-1419, 2004.
- [11] J.L. Miguez, S. Murillo, J. Porteiro J, "Feasibility of a new domestic CHP tri generation with heat pump: II. Availability analysis", *Applied Thermal Engineering*, vol.24, pp. 1421-1429, 2004.
- [12] G. Gigliucci , L. Petruzzi , E. Cerelli, "Demonstration of a residential CHP system based on PEM fuel cells", *Journal of Power Sources*, vol. 131, pp. 62-68, 2004.
- [13] X.Q. Kong, R.Z. Wang, X.H. Huang, "Energy efficiency and economic feasibility of CCHP driven by sterling engine", *Energy Conversion and Management*, vol.45, pp. 1433-1442, 2004.
- [14] K.M. Maribu, R. Firestone , C. Marnay, A.S. Siddiqui, "Distributed energy resources market diffusion model", *Energy Policy*, vol. 35, pp. 4471–4484, 2007.
- [15] G.G. Maidment, R.M. Tozer, "Combined cooling heat and power in supermarkets", *Applied Thermal Engineering*, vol. 22, pp. 653–665, 2002.
- [16] D. Ziher, A. Poredos, "Economics of a three-generation system in a hospital", *Applied Thermal Engineering*, vol. 26, pp. 680–687, 2006.
- [17] E. Cardona, P.Sannino, A.Piacentino, F.Cardona, "Energy saving in airports by three-generation. Part II: Short and long term planning for the Malpensa 2000 CHCP plant", *Applied Thermal Engineering*, vol. 26, pp. 1437–1447, 2006.
- [18] A. Bejan, *Advanced Engineering Thermodynamics*. New York: John Wiley & Sons, 1988.
- [19] A. Mozafari, and A. Ahmadi and M.A. Ehyaei, "Optimization of micro gas turbine by exergy, economic and environmental (3E) analysis", *IJ Exergy*, vol. 7, pp. 1–19, 2010.