

# A Computational Comparison between Revetec Engine and Conventional Internal Combustion Engines on the Indicated Torque

Maisara Mohyeldin Gasim, A. K. Amirruddin, and A. Shahrani

**Abstract**—This paper investigates the effect of replacing crankshaft with cam on the indicated torque during compression and power strokes in internal combustion engines. A Cycloidal cam profile was used in Revetec engine to calculate and compare the torque to a conventional engine, using a computational method. Firstly, the cylinder pressure was calculated using Ferguson equation, and then the torque calculated depending on cylinder pressure values in every crank angle. The results showed that by using Cycloidal cam profile in Revetec engine the torque can be increased by 14% compared with conventional engines, which means an increase in engine efficiency.

**Keywords**—Revetec engine, indicated torque, cam profile.

## I. INTRODUCTION

EFFICIENCY of conventional IC engines is less than 50% percent due to heat and friction losses. About two-third of the input energy is lost in exhaust gases and water cooling [1], and the mechanical losses due to friction are about 8% [2].

Due to economic crisis and shortness of oil resources, efforts are done to increase IC engines efficiency by reducing the heat and friction losses.

All conventional IC engines are using crankshafts to convert the piston reciprocating motion to a rotating motion in the drive line, but crankshafts are responsible of side thrust force, vibrations and also they are not efficient in transferring the power to the drive line.

Crank-less and free piston engines were a good example to overcome the crank shaft problems, but these new kinds of engines are facing a control and starting problems [3].

In 1996, an Australian engineer called Bradley Howell Smith, managed to produce a new mechanism to convert the reciprocating motion of the internal combustion engines pistons, to rotating motion in the drive line, by using a three-lobed counter rotating cams and called the new engine arrangement as Revetec engine [4].

In Revetec engine, shown in Figure 1, there are two opposite pistons controlled by two (three-lobed) cams. On both sides of each piston, there are two bearing which act as the follower for the cams. As each cam has three arms (three-lobed), meaning, in every two cycles of engine there are three power strokes compared to one power stroke in the conventional

engines, and every stroke in Revetec engine completed in just 60 degrees instead of 180 degrees in conventional engines.

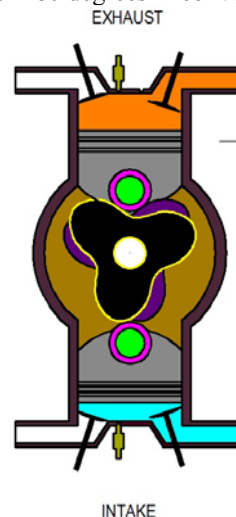

Fig. 1 Revetec engine with two cylinders

The cam profile contributes great effect in the engine performance, because the cam profile controls the piston motion, meaning that by changing the cam profile the piston motion will change too. There is a wide variety of cam motion schemes, but the main motions for cams followers, are: simple harmonic, constant acceleration and Cycloidal motion [5]. Cycloidal motion is the best profile for high speed engines because it has a very smooth motion curves and does not have the sudden change in acceleration at the ends of the motion [5].

## II. TORQUE CALCULATIONS

(a) Conventional IC engines

Figure 2 shows the piston force balance in conventional engines, from the figure:

$$T = \left( P \frac{\pi}{4} b^2 - m \cdot a \right) \cdot (r \cos \theta + l \cos \phi) \cdot \tan \phi \quad (1)$$

Where

$$\phi = \sin^{-1} \left( \frac{r}{l} \sin \theta \right) \quad (2)$$

$$a = -r \omega^2 \left( \cos \theta + \frac{\cos 2\theta}{n} \right) \quad (3)$$

$$n = \frac{l}{r} = 4 \quad (4)$$

Table 1 shows the cylinder pressure versus crank angle in compression and power strokes for a spark –ignition engine with the following data:

Compression ratio ( $r$ ) = 10

Specific heat ratio ( $\gamma$ ) = 1.3

Heat addition ( $Q/PV$ ) = 20

Maisara Mohyeldin Gasim is with Universiti Malaysia Pahang, Faculty of Mechanical Engineering .Malaysia (phone: 0060-169620591; fax: 0060-94242022; e-mail: maisara@ump.edu.my).

A. K. Amirruddin., is with Universiti Malaysia Pahang, Faculty of Mechanical Engineering. Malaysia

A. Shahrani is with Universiti Malaysia Pahang, Faculty of Mechanical Engineering .Malaysia

TABLE I  
 CYLINDER PRESSURE VALUES

Crank angle (θ)	Pressure (P/P <sub>1</sub> )	Crank angle (θ)	Pressure (P/P <sub>1</sub> )
-180	1.000	0.000	58.915
-170	1.009	10	69.609
-160	1.0364	20	59.193
-150	1.0842	30	44.020
-140	1.1556	40	30.933
-130	1.2559	50	23.387
-120	1.3929	60	17.563
-110	1.5784	70	13.581
-100	1.8303	80	10.817
-90	2.1753	90	8.8630
-80	2.6549	100	7.4572
-70	3.3332	110	6.4310
-60	4.3107	120	5.6749
-50	5.7401	130	5.1167
-40	7.8334	140	4.7082
-30	10.953	150	4.4173
-20	17.543	160	4.2227
-10	34.065	170	4.1108

Taking an assumption of cylinder and crank geometry as following:

Cylinder bore (b) = 0.076 m

Crank arm (r) = 0.023 m

Connecting rod (l) = 0.092 m

Piston mass (m) = 0.4 kg

Initial pressure (P<sub>1</sub>) = 1 bar = 100000 N/m<sup>2</sup>

Angular speed (ω) = 150 rad/s

Sample of calculations:

At crank angle θ = 40°, the cylinder pressure, from Table 1, P = 30.933.

From equation (3) the acceleration

$$\alpha = -0.023 \times 150^2 \left( \cos 40 + \frac{\cos 2 \times 40}{4} \right) = -418.893 \text{ m/s}^2$$

$$\varphi = \sin^{-1} \left( \frac{1}{4} \sin 40 \right) = 9.247^\circ$$

$$T = \left( 31.915 \times 100000 \times \frac{\pi}{4} \times 0.076^2 - 0.4 \times -418.893 \right) \times (0.023 \cos 40 + 0.092 \cos 9.247) \cdot \tan 9.247 = 250.675 \text{ N.m}$$

The results are shown in figure 3.

(b) Revetec engine

To ensure a fair comparison between Revetec engine and conventional IC engines, the same bore (b), stroke (h = 2r), piston mass (m) and initial pressure (P<sub>1</sub>) are kept the same for both types of engines. Also the angular speed (ω) in the case of Revetec engine is reduces to 50 rad/ s, because in Revetec engine the compression and power strokes just take 120° instead of 360° in conventional engines.

The equations to calculate the power in Revetec engine, revering to figure 4, are:

$$T = \left( P \frac{\pi}{4} b^2 - m \cdot a \right) \cdot (s + R_{fb}) \cdot \tan \varphi \quad (5)$$

Where:

$$\alpha = \frac{2\pi h \omega^2}{\beta^2} \sin \left( \frac{2\pi \theta}{\beta} \right) \quad (6)$$

$$s = h \left[ \frac{\theta}{\beta} - \frac{1}{2\pi} \sin \left( \frac{2\pi \theta}{\beta} \right) \right] \quad (7)$$

$$\varphi = \tan^{-1} \left[ \frac{v (R_{fb} + s)}{\omega (R_{fb} + s)^2} \right] \quad (8)$$

$$v = \frac{h \omega}{\beta} \left[ 1 - \cos \left( \frac{2\pi \theta}{\beta} \right) \right] \quad (9)$$

Also to keep the size of both engines approximately equal, the summation of cam basic circle radius R<sub>b</sub> and the follower roller radius R<sub>r</sub> is equal to connecting rod length l minus the crank arm length r, i.e. R<sub>fb</sub> = L - r = 0.069.

Sample of calculation:

At crank angle θ = 30°, the cam angle will be θ = 10°, and the cylinder pressure, from Table 1, P = 44.020

$$v = \frac{2 \times 0.023 \times 50}{60 \times \pi / 180} \left[ 1 - \cos \left( \frac{2\pi \times 10}{60} \right) \right] = 1.1 \text{ m/s}$$

$$s = 2 \times 0.023 \left[ \frac{10}{60} - \frac{1}{2\pi} \sin \left( \frac{2\pi \times 10}{60} \right) \right] = 0.001325$$

$$\varphi = \tan^{-1} \left[ \frac{1.1 (0.069 + 0.001325)}{50 (0.069 + 0.001325)^2} \right] = 17.34^\circ$$

$$\alpha = \frac{2\pi \times 2 \times 0.023 \times 50^2}{(60 \times \pi / 180)^2} \sin \left( \frac{2\pi \times 10}{60} \right) = 570.752 \text{ m/s}^2$$

$$T = (44.020 \times \frac{\pi}{4} \times 0.076^2 - 0.4 \times 570.752) \cdot (0.001325 + 0.069) \cdot \tan 17.34 = 443.5 \text{ N.m}$$

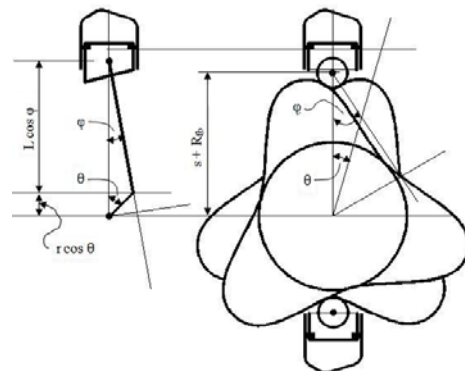

Fig. 2 conventional and Revetec engines

### III. RESULTS AND DISCUSSION

When using cam instead of crankshaft in IC engines and depending on cam profile the cylinder pressure will be different from conventional engines. But also to ensure equal comparison circumstances, the same cylinder pressure for conventional engines was used to calculate the indicated torque in Revetec engine. Figure 3 shows the indicated torque diagram for conventional and Revetec during compression and power strokes.

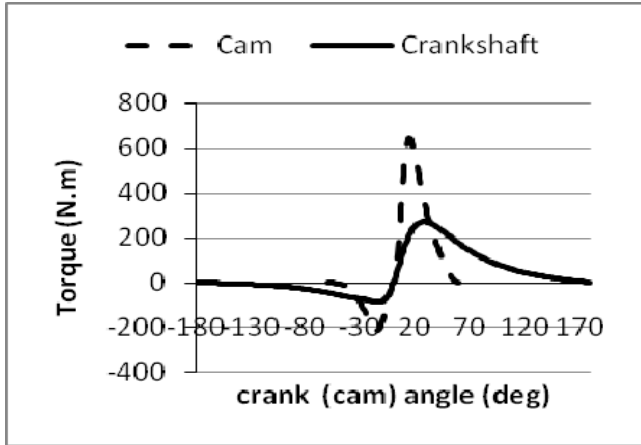

Fig. 3 indicated torque during the compression and power strokes

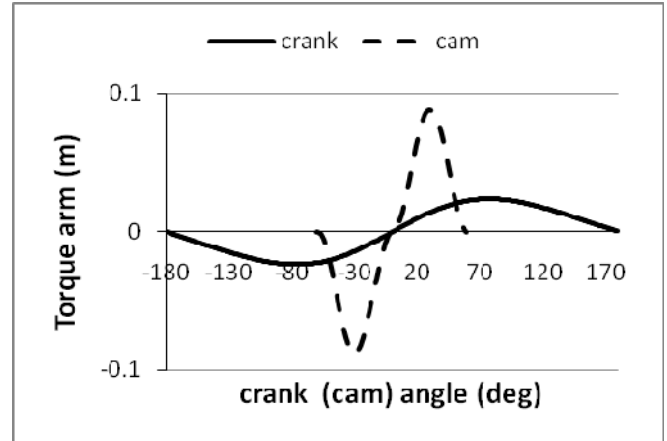

Fig. 5 Torque arm comparison between conventional and Revetec engine

The graph in Figure 3 shows the indicated torque in both types of engines, from the graph it is clear that the maximum torque when using conventional engine is about 260 N.m, and when using Revetec engine the torque increased to reach more than 600 N.m. which means that Revetec engine produced more torque with the same stroke and cylinder size compared with conventional engines. From equation (1) and (5) the torque in both engines is depend on: the cylinder pressure (P), the acceleration (which can be considered same for both engines), and the torque arm. In the case of conventional IC engines the torque arm is:

$$(r \cos \theta + l \cos \varphi) \cdot \tan \varphi$$

Where  $\varphi$  is the angle of rotation of the crank, when it is measured from top dead center.

In the case of Revetec engine the torque arm is:

$$(s + R_{fb}) \cdot \tan \varphi$$

And  $\varphi$  in this case is the pressure angle. Figure 4 illustrates the values of  $\varphi$  in both engines, and figure 5 shows the comparison between the torque arm on both engines.

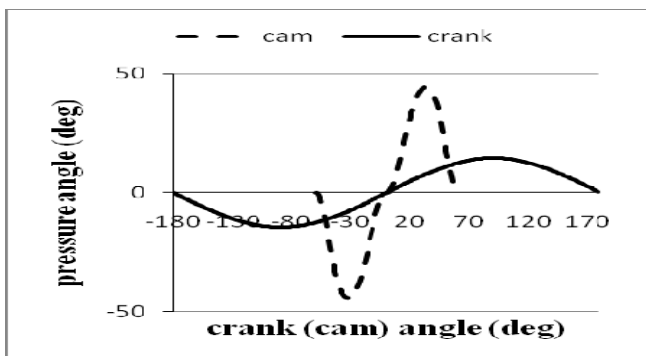

Fig. 4 Pressure angle comparison between conventional and Revetec engine

From figure 4 and 5 the torque arm is bigger in the case of Revetec engine, because the bigger pressure angle and the radius of base circle and the radius of follower roller gives more torque arm to Revetec engine.

#### IV. CONCLUSION

In conventional internal combustion engine the stroke length is twice the crank arm length,  $s = 2r$ , and because of using connecting rod to link the piston to the crank arm, the maximum torque arm is equal to crank arm  $r$ . but when using Revetec engine with the same stroke, the cam base circle radius and the follower roller radius gives more length to the torque arm, which means more torque.

#### REFERENCES

- [1] V. Pandiyarajan , M. Chinna Pandian , E. Malan , R. Velraj, R.V. Seeniraj, Experimental investigation on heat recovery from diesel engine exhaust using finned shell and tube heat exchanger and thermal storage system, 2010, Applied Energy 88 (2011) 77–87
- [2] F. A. Davis and T. S. Ewe, Piston ring and cylinder bore friction and wear, 1990, Tribology International 0301-679X/90/030163-9 © 1990 Butterworth-Heinemann Ltd
- [3] Mikalsen R., Roskilly A.P., Performance simulation of a spark ignited free-piston engine generator, Applied Thermal Engineering 28 (2008) 1726–1733
- [4] Engine, W.O., international Patent classification F02B 75/24 (2006.01)
- [5] Myszka David H., Machines and Mechanism, Pearson Education Internationa, 2005.