

# Comparison between Batteries and Fuel Cells for Photovoltaic System Backup

M. Sedighzadeh, and A. Rezazadeh

**Abstract**—Batteries and fuel cells contain a great potential to back up severe photovoltaic power fluctuations under inclement weather conditions. In this paper comparison between batteries and fuel cells is carried out in detail only for their PV power backup options, so their common attributes and different attributes is discussed. Then, the common and different attributes are compared; accordingly, the fuel cell is selected as the backup of Photovoltaic system. Finally, environmental evaluation of the selected hybrid plant was made in terms of plant's land requirement and lifetime  $CO_2$  emissions, and then compared with that of the conventional fossil-fuel power generating forms.

**Keywords** —Fuel Cell, PV Cell, Hybrid Power Plant.

## I. INTRODUCTION

AS energy storage devices, batteries continue to be applied to electric power utilities for drawing benefits of peak shaving and load leveling. Battery energy storage facilities provide the utilities additional dynamic benefits such as voltage and frequency regulation, load following, spinning reserve, and power factor correction [1] and [2]. Applications of the storage batteries to power systems are predicted to grow in the future due to those benefits coupled with the ability to provide peak power.

Fuel cell power generation is another attractive option for providing power for electric utilities and commercial buildings because of its high efficiency and environmentally benign feature. This type of power production is especially economical (i) where potential users are faced with high cost in electric power generation from coal or oil, (ii) where environmental constraints are stringent, or (iii) where load constraints of transmission and distribution systems are so tight that their new installations are not possible.

## II. COMMON ATTRIBUTES

Photovoltaic power outputs vary depending mainly upon solar insolation and cell temperature. Since control of the ambient weather conditions is beyond human beings' capability, it is almost impossible for human operators to control the PV power itself. Thus, a PV power generator may sometimes experience sharp output power fluctuations owing to intermittent weather conditions, which causes control

problems such as load frequency control, generator voltage control and even system stability analysis. There is, therefore, a need for backup power facilities in the PV power generation. Batteries and fuel cells are the most likely technologies to provide the PV system with backup power because these two backup power sources contain some distinct features in common. Those characteristics are listed below.

### A. Fast Load-Response Capability

Fuel cells and batteries are able to respond very fast to load changes because their electricity is generated by chemical reactions [3]-[5].

### B. Modularity in Production

Factory assembly of standard cell units provides fuel cell and battery power plants with short lead-time from planning to installation. This modular production enables them to be added in discrete increments of capacity, which allows better matching of the power plant capacity to expected load growth. In contrast, the installation of a single large conventional power plant may produce excess capacity for several years, especially if the load growth rate is low.

### C. Highly Reliable Sources

Due to their multiple parallel modular units and absence of electromechanical rotating masses, fuel cell and battery power plants are more reliable than any other forms of power generation [6]. Consequently, a utility that installs a number of fuel cell or battery power plants is able to reduce its reserve margin capacity while maintaining a constant level of the system reliability.

### D. Flexibility in Site Selection (Environmental Acceptability)

The electrochemical conversion processes of fuel cells and batteries are very quiet because they do not have any major rotating masses. External water requirement for their operation is, if any, very little while conventional power plants require massive amount of water for system cooling. Therefore, they can reduce or eliminate water quality problems created by the conventional plants' thermal discharges. Air pollutant emission levels of fuel cells and batteries are none or very little. Emissions of  $SO_2$  and  $NO_x$  in the fuel cell power plant are values are projected to be about 1,000 times smaller than those of fossil-fuel power plants since fuel cells do not rely on a fuel-burning process [6]. These environmentally benign characteristics make it possible for those power plants to be located close to load centers in urban and suburban area. It can also reduce energy losses and costs associated with

Manuscript received October 6, 2007

Authors are with Faculty of Electrical and Computer Engineering, Shahid Beheshti University, Tehran, 1983963113, Iran (phone: +98-21-29902290, fax: +98-21-22431804, e-mail: m\_sedighi@sbu.ac.ir).

transmission and distribution equipment. These sitting near load centers may also reduce the likelihood of system blackouts.

### III. DIFFERENT ATTRIBUTES

Electric current is produced in a storage battery by chemical reactions. The same chemical reactions take place in a fuel cell, but there is a difference between them with respect to fuel storage. In storage batteries chemical energy is stored in the positive/negative electrodes of the batteries. In fuel cells, however, the fuels are stored outside the cells and need to be fed into the electrodes continuously when the fuel cells are required to generate electricity. Other detailed comparison between battery backup and fuel cell backup for PV power supplement is made in the following sections.

#### A. Efficiency

Power generation in fuel cells directly convert available chemical free energy to electrical energy rather than going through heat exchange processes. Thus, it can be said that fuel cells are a more efficient power conversion technology than the conventional steam-applying power generations. Figure 1 illustrates energy conversion processes for a conventional power generator and a fuel cell.

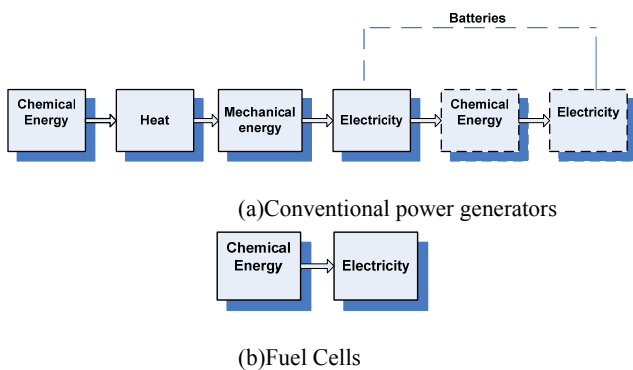

Fig. 1 Comparison of energy conversion processes

Whereas the fuel cell is a one-step process to generate electricity, the conventional power generator has several steps for electricity generation and each step requires a certain amount of energy loss. Fuel cell power systems have around 40-60% efficiencies depending on the type of electrolytes and independent of size.

Battery power systems themselves have high energy efficiencies, but their overall system efficiencies from raw fuel (mostly coal or nuclear) through the batteries to converted as power are reduced to below 30%. This is because energy losses take place whenever one energy form is converted to another.

#### B. Capacity Variation

As the battery discharges, its terminal voltage, gradually decreases. The fall of the terminal voltage on discharge is due to its internal resistance. However, the internal resistance of a battery varies with its cell temperature and state of discharge. The decrease in battery voltages with increasing discharge currents and also a reduction in battery capacity with

increasing rate of discharge is clearly seen in Table 1 [7]. For fuel cell power systems, they have equally high efficiency at both partial and full loads as can be seen in Figure 2 [4]. The customer's demand for electrical energy is not always constant. So for a power utility to keep adjustment to this changing demand, either large base-load power plants must sometimes operate at part load, or smaller peaking units must be used during periods of high demand. Both way, efficiency suffers and pollution increases.

Fuel cell systems have a greater efficiency at full load and this high efficiency is retained as load diminishes, so inefficient peaking generators may not be needed.

TABLE I  
 CAPACITY VARIATION OF A BATTERY AT VARIOUS DISCHARGE RATES

Discharge Rate	Mean Voltage(v)	Current(A)	Wh Capacity	%Wh Capacity
20 hr	11.85	2	474	100
10 hr	11.75	3.7	435	92
5 hr	11.55	6.5	375	79
1 hr	11.40	22	251	53

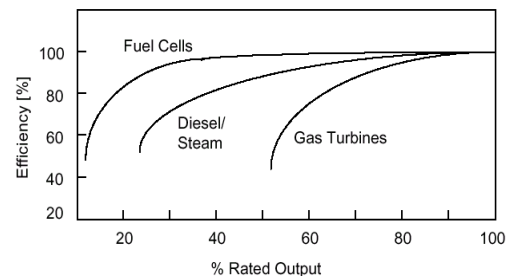

Fig. 2 Equally high efficiency of fuel cells at partial and full loads

#### C. Flexibility in Operation

Fuel cells have an advantage over storage batteries in the respect of operational flexibility. Batteries need several hours to be taken for recharging after they are fully discharged. During discharge the batteries' electrode materials are lost to the electrolyte, and the electrode materials can be recovered during the recharging process. Fuel cells, on the other hand, do not undergo such material changes. The fuel stored outside the cells can quickly be replenished, so they do not run down as long as the fuel can be supplied. Figure 3 illustrates the energy density of fuel cells compared with lead-acid batteries [7]. The fuel cells show higher energy density than the batteries when they operate for more than 2 hours. It means that fuel cell power systems with relatively small weight and volume can produce large energy outputs.

It is to suppress the PV power fluctuations due to the changes of solar intensity and cell temperature. The fact that the PV power outputs change sharply under inclement weather conditions makes it hard to decide the capacity of the battery power plants since their discharging rates are not constant. For a lead-acid

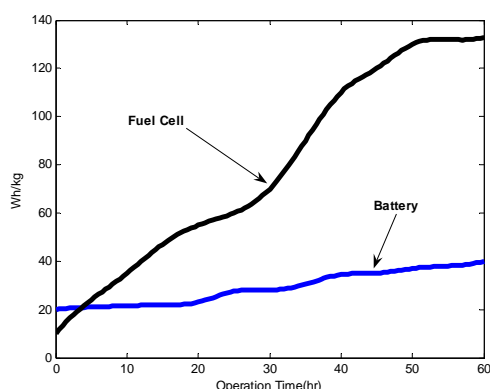

Fig. 3 Energy densities for fuel cells and batteries.

battery, the most applicable battery technology for photovoltaic applications to date, the depth of discharge should not exceed 80% because the deep discharge cycle reduces its effective lifetime. In order to prevent the deep discharge and to supplement varying the PV powers generated on inclement weather days, the battery capacity must be large. From Figure 4, that shows two different PV power variations, the dotted curve requires a larger battery capacity than the other curve. Moreover, the large battery capacity is usually not fully utilized, but for only several days.

Fuel cells integrated with photovoltaic systems can provide smoother operation. The fuel cell system is capable of responding quickly enough to level the combined power output of the hybrid PV-fuel cell system in case of severe changes in PV power output. Such a fast time-response capability allows a utility to lower its need for on-line spinning reserve. The flexibility of longer daily operation also makes it possible for the fuel cells to perform more than the roles of gas-fired power plants. Gas turbines are not economical for a purpose of load following because their efficiencies become lower and operating costs get higher at less than full load conditions.

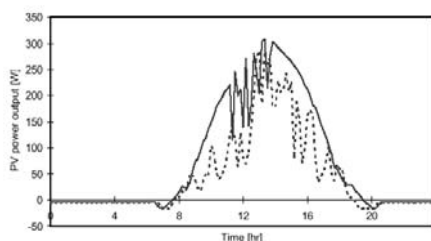

Fig. 4 PV power variations requiring different battery capacities

#### D. Cost

The history of fuel cell equipment costs has shown that the price of fuel cells has dropped significantly as the commercial market grows and the manufacturing technology becomes mature. Initial cost of phosphoric acid fuel cell power plants was \$5,500/kW and the current system cost is about \$3,000/kW [8]. This cost is expected to decrease further to around \$1,500/kW in future [9].

A lead-acid battery power plant has currently the lowest battery cost at around \$150/kWh because it has been the longest and most fully developed battery technology. The

battery cost is projected to reduce to \$100/kWh in the future. Nickel-cadmium (NiCd) batteries are 4 to 5 times more expensive than the lead-acid types. Once the NiCd batteries are fully mature, their price will drop but they will not be as low as the lead-acid ones because of the raw material cost.

#### IV. ENVIRONMENTAL EXTERNALITY

During their life cycle operation, fuel cell power plants produce environmental externalities in the process of fuel reforming. However, storage batteries themselves do not contain any environmental impacts even though the battery charging sources produce various emissions and solid wastes. A fuel cell power system emits by far less  $SO_2$ ,  $NO_x$  and other particulates in the fuel reforming process compared to conventional fossil fuel power plants.

The amount of  $CO_2$  emissions from the fuel cell system is similar to that from conventional fossil-fuel power plants, but the fuel cell system's high efficiency ranging from 40% to 60% results in lower  $CO_2$  emissions.

Batteries themselves do not produce any emissions during their operation period even if the power sources providing the batteries with charging power usually at off-peak time generate several chemical emissions and solid wastes. The batteries displace power generation rather than replace it. Therefore, the batteries' environmental impacts should be computed based on the baseload fuel mix used to charge the batteries. For instance, the  $CO_2$  emissions from fuel cell power plants were calculated as 376.43 kg  $CO_2$  /MWh, where the efficiencies of the fuel reformer and the power plant are assumed to be 95% and 45% respectively. For batteries, the  $CO_2$  emissions of the power sources that charge the batteries at off-peak should be computed. When the fuel mix during a charging period of the batteries is supposed to be 40% of nuclear power and 60% of coal power, then the batteries'  $CO_2$  emission rate would be 714.3 kg  $CO_2$  /MWh.

When fuel cell power plants are to be dismantled at the end of their commission, they do not exhibit any detrimental impacts on environment and no specific hazards are encountered. Component recovery rather than waste disposal is likely to be the issue. In phosphoric-acid fuel cells, nickel from the fuel reformer catalyst and platinum from the anode and cathode will require recovery. For molten-carbonate fuel cells, nickel from both the electrodes and the reforming catalysts can be recovered. In solid-oxide fuel cells, nickel and zirconium-containing ceramic components are likely to be recovered. However, for battery power plants a significant amount of care is required to be taken of their disposal to prevent toxic materials from spreading around. All batteries that are commercially viable or under development for power system applications contain hazardous and toxic materials such as lead, cadmium, sodium, sulfur, bromine, etc. Since the batteries have no apparent salvage value and must be treated as hazardous wastes, disposal of spent batteries is an issue. Recycling batteries is encouraged rather than placing them in a landfill. One method favoring recycling of spent batteries is regulation. Thermal treatment for the lead-acid and cadmium-containing batteries is needed to recover lead and cadmium.

Sodium-sulfur and zinc-bromine batteries are also required to be treated before disposal.

#### V. ENVIRONMENTAL EVALUATION PV-FUEL CELL HYBRID POWER PLANT

Finally, It was found that the fuel cell power has more beneficial effects over the battery power when operates with a utility-connected PV power station. In following sections, environmental evaluation of the proposed hybrid plant was made in terms of plant's land requirement and lifetime emissions, and then compared with that of the conventional fossil-fuel power generating forms. Fuel cell systems produce very little amounts of  $SO_2$ ,  $NO_x$  and other particulates in the fuel reforming process and their low  $CO_2$  emissions result from high energy conversion efficiency [10, 11]. As two major criteria for calculating environmental impacts of the proposed PV-fuel cell hybrid system, land requirement for the power plant and its lifetime  $CO_2$  emissions are considered. A requirement of land area would nearly soon is a crucial factor for power station construction in densely populated regions. The world's rising concern about the increasing  $CO_2$  concentration in the atmosphere and its potential impact on global warming gives a suggestion that  $CO_2$  emission rates be considered in selecting electricity generating technologies. Land area requirement and lifetime  $CO_2$  emissions for PV, fuel cell, and conventional fossil fuel power plants are studied in the next parts of this paper, respectively.

##### A. Land Requirement

The land area required for each electric power plant varies over a significant range, depending upon factors such as individual utility design specifications, land costs, and the installed capacity. Photovoltaic modules that provide power for remote systems are useful with small land disturbance, but, when used for a grid-connected central power station, land requirement is a major consideration. A PV power plant requires the most extensive land due to the low energy density of solar radiation and low efficiencies of solar cells [12]. The amount of land needed for the installation of a fuel cell power plant may be relatively small owing to the capability of its modular construction [13]. This feature, together with very low environmental impact, may allow fuel cell power plants to be located close to the point of use, where its waste heat can be used in cogeneration applications. Table 2 summarizes the standard figures of land use for electricity generating power plants, including conventional fossil-fuel power sources [14]. For coal plants, land area required for ash and flue gas desulfurization (FGD) waste disposal is included. Since oil and natural gas-fired power plants do not need ash disposal, the land required for their power plant construction is much lower than that of coal power plants.

TABLE II  
 LAND REQUIREMENT FOR ELECTRIC POWER PLANTS

Power Source	Land Use [ $m^2 / MW$ ]
Photovoltaic	20,000
Fuel Cell	700
Coal	3,700*
Oil	900
Natural Gas	800

\* Includes land needed for solid waste disposal.

##### B. $CO_2$ Emissions

This section calculates the lifetime  $CO_2$  emissions from photovoltaic with polycrystalline silicon, phosphoric acid fuel cells, and three conventional fossil fuel (coal, oil and natural gas) power plants. The 30-year lifetime  $CO_2$  emissions for those power plants are summarized in Table 3. The total  $CO_2$  amount generated during a power plant's lifetime is calculated by adding the  $CO_2$  produced during its construction to the  $CO_2$  produced from burning fuels and from its operation and maintenance (O&M).

TABLE III  
 $CO_2$  EMISSIONS FOR ELECTRIC POWER PLANTS WITH A 30 YEAR LIFETIME

Power Sources	$CO_2$ from plant construction* [Kg/MWh]	$CO_2$ from O&M [Kg/MWh]	$CO_2$ from burning fuel [Kg/MWh]	Total $CO_2$ emissions [Kg/MWh]
Photovoltaic	81.8	9	-	90.8
Fuel Cell	0.9	8	461.4	470.3
Coal	3.5	28	987.4	1018.9
Oil	6.4	16	738.5	760.9
Natural Gas	2.7	10	551.4	564.1

\* For the calculation, capacity factors for coal, oil, natural gas and fuel cell power plants are 65%, 25%, 25%, and 25%, respectively.

##### C. Evaluation of the PV-Fuel Cell Hybrid Power Plant

Environmental impacts of the proposed PV-fuel cell hybrid power plant are going to be evaluated in terms of land area requirement and life cycle  $CO_2$  emissions. According to the Table I, the land requirement for photovoltaic power stations is 6-25 times higher compared to the other forms of power generation. Fuel cell power plants need the least land area for plant construction. When these two power plants are integrated, land requirement for the hybrid plant would decrease so that the PV power could get an applicable position to be located near highly populated area.

From the Table III, photovoltaic power plants produce 6-11 times less lifetime  $CO_2$  gas than other power generating sources and the  $CO_2$  emissions from fuel cell power plants also very little. So, the hybrid power plant has an excellent potential to reduce lifetime  $CO_2$  emissions.

Fig. 5 shows the comparison result of the proposed hybrid power plant with other power generation forms in terms of land surface requirement and lifetime  $CO_2$  production.

Thus, fuel cell power generation, having the least land use, is able to alleviate the heavy burden for large surface

requirement of the PV power plants. It also has a fast-ramping capability to smoothen the fluctuating PV power outputs. Moreover, the hybrid power plant has a very little potential for lifetime  $CO_2$  emissions because the PVs and fuel cells are the power sources that produce the least lifetime  $CO_2$  emissions.

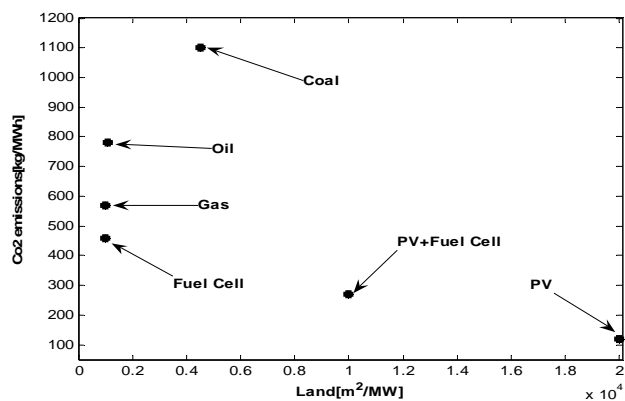

Fig. 5 Land requirement and lifetime  $CO_2$  emissions for electric power plants

## VI. CONCLUSION

This paper compared in detail the above two technologies for the PV power backup. It was found that the fuel cell power has more beneficial effects over the battery power when operates with a utility-connected PV power station. Environmental evaluation of the PV-fuel cell hybrid power plant is made in terms of land requirement for the plant construction and lifetime  $CO_2$  emissions. The  $CO_2$  emissions of the hybrid power plant are caused by fuel consumption during its life-long period, and its construction and O&M work. Then, the environmental evaluation of the hybrid power plant is compared with those of the conventional fossil-fuel power generation forms. Fuel cell power and PV power have uniquely excellent characteristics in land requirement and  $CO_2$  emissions, respectively. The PV power, however, requires extensive land for the plant construction. The fuel cell power plant emits moderate amount of  $CO_2$  gas to the atmosphere during its operation. Therefore, the combination of the PV and the fuel cell power utilizes the merits of the two power sources and alleviates their disadvantages.

## REFERENCES

- [1] J.W. Hurwitsch and C.A. Carpenter, 'Technology and Application Options for Future Battery Power Regulation', *IEEE Transactions on Energy Conversion*, Vol. 6, No. 1, March 1991, pp. 216-223.
- [2] D. Kottick, M. Blau and D. Edelstein, 'Battery Energy Storage for Frequency Regulation in an Island Power System', *IEEE Transactions on Energy Conversion*, Vol. 8, No. 3, September 1993, pp. 455-458.
- [3] H.J. Kunisch, K.G. Kramer and H. Dominik, 'Battery Energy Storage: Another Option for Load-Frequency-Control and Instantaneous Reserve', *IEEE Transactions on Energy Conversion*, Vol. EC-1, No. 3, September 1986, pp. 41-46.
- [4] M. Hsu, 'Ztek's Ultra-High Efficiency Fuel Cell/Gas Turbine System for Distributed Generation', *1996 Fuel Cell Seminar*, Nov. 17-20, 1996, Orlando, Florida, pp. 183-186.

- [5] R.C. Ruhl, M.A. Petrik and T.L. Cable, 'Status of the TMI Systems', *1996 Fuel Cell Seminar*, Nov. 17-20, 1996, Orlando, Florida, pp. 187-189.
- [6] W. Shireen and M.S. Arefeen, 'An Utility Interactive Power Electronics Interface for Alternate/Renewable Energy Systems', *IEEE Transactions on Energy Conversion*, Vol. 11, No. 3, September 1996, pp. 643-648.
- [7] K. Tam, P. Kumar and M. Foreman, 'Enhancing the Utilization of Photovoltaic Power Generation by Superconductive Magnetic Energy Storage', *IEEE Transactions on Energy Conversion*, Vol. 4, No. 3, September 1989, pp. 314-321.
- [8] 'Federal Technology Alert - Natural Gas Fuel Cells', 1996, [http://w3.pnl.gov:2080/fta/5\\_nat.htm](http://w3.pnl.gov:2080/fta/5_nat.htm).
- [9] Technology Transition Corporation, 'The Entry Market for Fuel Cells', 1996, <http://www.corp.com/fccg/fcmabstr.htm>
- [10] H. Matsuda, 'Interconnecting Dispersed Photovoltaic Power Generation Systems with Existing Utility Grid: A Study at ROKKO Inland Test Facility, Japan', *Int. J. Solar Energy*, 1992, Vol. 13, pp. 1-10.
- [11] S. Matsumoto et al., 'Performance Model of Molten Carbonate Fuel Cell', *IEEE Transactions on Energy Conversion*, Vol. EC-5, No. 2, June 1990, pp. 252-257.
- [12] H. Schaefer and G. Hagedorn, 'Hidden Energy and Correlated Environmental Characteristics of PV Power Generation', *Renewable Energy*, Vol. 2, No. 2, pp. 159-166, 1992.
- [13] L.J. Blomen and M.N. Mugerwa, *Fuel Cell Systems*, Plenum Press, New York, 1993.
- [14] G. Marland, 'Carbon Dioxide Emission Rates for Conventional and Synthetic Fuels', *Energy*, Vol. 8, No. 12, 1983, pp.981-992.



**M. Sedighzadeh** received the B.S. degree in Electrical Engineering from the Shahid Chamran University of Ahvaz, Iran and M.S. and Ph.D. degrees in Electrical Engineering from the Iran University of Science and Technology, Tehran, Iran, in 1996, 1998 and 2004, respectively. From 2000 to 2007 he was with power system studies group of Moshanir Company, Tehran, Iran. Currently, he is an Assistant Professor in the Faculty of Electrical and Computer

Engineering, Shahid Beheshti University, Tehran, Iran. His research interests are Power system control and modeling, FACTS devices and Distributed Generation.



**A. Rezazade** was born in Tehran, Iran in 1969. He received his B.Sc and M.Sc. degrees and Ph.D. from Tehran University in 1991, 1993, and 2000, respectively, all in electrical engineering. He has two years of research in Electrical Machines and Drives laboratory of Wuppertal University, Germany, with the DAAD scholarship during his Ph.D. and Since 2000 he was the head of CNC EDM Wirecut machine research and manufacturing center in Pishraneh company. His research interests include

application of computer controlled AC motors and EDM CNC machines and computer controlled switching power supplies. Dr. Rezazade currently is an assistant professor in the Power Engineering Faculty of Shahid Beheshti University.