

CB_{CTL} : A Reasoning System of Temporal Epistemic Logic with Communication Channel

Suguru Yoshioka and Satoshi Tojo

Abstract—This paper introduces a temporal epistemic logic CB_{CTL} that updates agent's belief states through communications in them, based on computational tree logic (CTL). In practical environments, communication channels between agents may not be secure, and in bad cases agents might suffer blackouts. In this study, we provide *inform** protocol based on ACL of FIPA, and declare the presence of secure channels between two agents, dependent on time. Thus, the belief state of each agent is updated along with the progress of time. We show a prover, that is a reasoning system for a given formula in a given a situation of an agent ; if it is directly provable or if it could be validated through the chains of communications, the system returns the proof.

Keywords—communication channel, computational tree logic, reasoning system, temporal epistemic logic.

I. INTRODUCTION

AN agent is an autonomous computer system that perceives information from surrounding environments and takes relevant actions. Such an agent has been formalized in terms of logic as a rational agent [2], [10], especially in temporal epistemic logic[9]. BDI (belief-desire-intention) logic is a result of such effort, though it mainly treats an epistemic state of an isolated single agent; thus, it is rather clumsy to handle interaction of epistemic states in multiple agents.

One of the most important issues in multi-agent system is interaction, or communication, that may directly affect their epistemic states [11]. Thus far, several models which include the notion of communication have rather naively rendered that agents are always communicable, i.e., that channels between them are omnipresent. However, in practical cases, communication is not free. We should consider that reliable channels exist only between certain agents at certain time.

The purpose of this paper is to introduce a logic to treat epistemic states of multiple agents where channels are unevenly distributed. We show that in this logic we can decide whether an agent would come to know a formula of certain information after iterated communications through channels, updating her epistemic state. We implement the reasoning system for our logic on a computer in Prolog, and show that the system would decide the veridicality of such belief update in finite time, presenting examples.

In the following section, we propose a formalization of communication for our logic CB_{CTL} , and define the syntax and Kripke semantics. In Section III, we show the inference system and its decidability. In Section IV, we show a model

S. Yoshioka and S. Tojo are with the Japan Advanced Institute of Science and Technology.
e-mail:{s-yoshio,tojo}@jaist.ac.jp

checker for our logic and an example by our computer system. In the final section, we discuss some branching points of our theory and summarize our contribution.

II. LOGIC OF AGENT'S EPISTEMIC STATE WITH THE CHANNEL

A. Preliminaries

In this section, we introduce a temporal epistemic logic with communication channel CB_{CTL} , based on computational tree logic (CTL) [1], [3]. The logic has the branching time, so that each agent may have different epistemic state in future. Generally, when we consider multi-agent models, it is appropriate to include the branching time.

The language of CTL consists of propositional temporal operator EX , AU and EU . All are formed by a pair of symbols. The first symbols (A or E) are quantifiers and the second pair X and U mean 'next' and 'until', respectively. Temporal operators AX , EF , AF , EG , and AG are abbreviations of $EX\neg\varphi$, $E(trueU\varphi)$, $A(trueU\varphi)$, $AF\neg\varphi$, and $EF\neg\varphi$, respectively. Where the second pair G and F mean "some future state" and "all future states."

B. Revision of *inform**

At first, we formalize communication between agents, based on *inform* in ACL (Agent Communication Language) defined by FIPA (Foundations of Intelligent Physical Agents) [4]. The *inform* of ACL/ FIPA is well known as an existing formalization of communication between agents. A definition of this *inform* is given as follows:

Definition 1: [*inform*] $\langle\alpha, \text{inform}(\beta, \varphi)\rangle$
feasibility pre-condition: $B_\alpha\varphi \wedge \neg B_\alpha(Bif_\beta\varphi \vee Uif_\beta\varphi)$
rational effect: $B_\beta\varphi$

where $Bif_\beta\varphi$ and $Uif_\beta\varphi$ are abbreviation of ' $B_\beta\varphi \vee B_\beta\neg\varphi$ ' and ' $U_\beta\varphi \vee U_\beta\neg\varphi$ ', respectively. a formula $B_\beta\varphi$ is read as "Agent β believes φ ," and a formula $U_\beta\varphi$ is read as "Agent β is uncertain about φ , but thinks that φ is more likely than $\neg\varphi$."

We add the concept of a communication pathway, or *channel* [5], and a time progress in the above definition, revising its pre-condition and post-condition.

In this study, we exclude the epistemic operator U because there is no sound formalization of the U , though the later extensibility is preserved as we will discuss in Section V. At this stage, we use only an epistemic operator B_α . Then we

define our extended inform $inform^*$ as follows:

Definition 2: $\langle \alpha, inform^*(\beta, \varphi) \rangle$
 feasibility pre-condition: $B_\alpha \varphi \wedge \neg B_\alpha (Bif_\beta \varphi) \wedge C_{\alpha\beta}$
 rational effect: $X(B_\beta \varphi)$

Here, X is a temporal operator meaning “next state.” $C_{\alpha\beta}$ is a member of propositional variables, let us read $C_{\alpha\beta}$ to mean “there is a communication channel from Agent α to Agent β .” That is, $C_{\alpha\beta}$ is not equivalent to $C_{\beta\alpha}$.

In this paper, we define the Kripke model with communication based on CTL[1]. If we define a communication protocol as a modal operator, it is necessary to define its conditions for all the states of all the possible worlds. Avoiding such messy complications of modalities, we define a communication channel as a proposition and $inform^*$ as an action. That is, we deal with a communication protocol as a knowledge included in agent’s epistemic states. We will discuss other options in Section V.

C. Syntax

We introduce a temporal epistemic logic system CB_{CTL} for reasoning agent’s epistemic states with communications. In this logic, an agent’s epistemic state is modified by one time step per a communication. Therefore, the temporal operator is restricted only to the *next* operator X .

Definition 3 (Signature): The language L_{CB} consists of the following vocabulary.

- P a set of propositional variables
- C a set of communication channels
- Agent* a set of agents

In addition, the following symbols are used.

- \neg, \vee logical connectives
- EX temporal operator

B_α epistemic operator where $\alpha \in Agent$

Parentheses and punctuation are added if necessary.

Where the first symbol E of the temporal operator EX is an existential quantifier. We use $\varphi, \psi, \chi, \dots$ for propositional variables and α, β, \dots for agents.

Definition 4 (Formula): Formulae, denoted by φ, ψ, \dots , are constructed in the usual way from propositional variables, logical connectives and operators. In particular, $EX\varphi$ and $B_\alpha\varphi$ are formulae when φ is a formula. And we treat C the same as P .

Formulae $\varphi \wedge \psi, \varphi \rightarrow \psi, \varphi \Leftrightarrow \psi$, and $AX\varphi$ are abbreviations of $\neg(\neg\varphi \vee \neg\psi)$, $\neg\varphi \vee \psi$, $(\varphi \rightarrow \psi) \wedge (\psi \rightarrow \varphi)$, and $\neg EX\neg\varphi$, respectively.

D. Semantics of CB_{CTL}

Similar to other Kripke semantics, we give a Kripke model to CB_{CTL} . A model M is such a tuple that $M = \langle W, St_w, R_w, B_\alpha, V \rangle$, where W is a set of possible worlds, St_w is a set of states for each $w \in W$, R_w is a set of temporal relations for each $w \in W$, and B_α is a set of the accessibility

relations; if $(w, t, w') \in B_\alpha$ and $t \in St_w$ then $t \in St_{w'}$. And V is a valuation such that $V(w, t) = L(w, t) \cup CL(w, t)$, where L is a valuation for propositional variable such that $L(w, t) \subseteq P$ for each $w \in W, t \in St_w$, and CL is a valuation for communication channels such that $CL(w, t) \subseteq C$ for all $w \in W, t \in St_w$. A binary relation ‘ \models ’ is defined inductively as follows:

- $(M, w, t) \models \varphi$ iff $\varphi \in V(w, t)$
- $(M, w, t) \models \neg\varphi$ iff not $(M, w, t) \models \varphi$
- $(M, w, t) \models \varphi \vee \psi$ iff $(M, w, t) \models \varphi$ or $(M, w, t) \models \psi$
- $(M, w, t) \models B_\alpha\varphi$ iff $\forall w' \{ (w, t, w') \in B_\alpha \rightarrow (M, w', t) \models \varphi \}$
- $(M, w, t) \models EX\varphi$ iff $\exists t'$ such that $(t, t') \in R_w$ and $(M, w', t) \models \varphi$

III. REASONING SYSTEM WITH $inform^*$

We propose a reasoning system for CB_{CTL} . This reasoning system evaluates truth values of logical formulae in Kripke semantics. Since the communication is included in the reasoning process, the result would differ from that of usual evaluation in the model. That is, we need to add a new state in each world, that is a progress of one unit time, as a result of a communication. In the new state, newly validated formulae are included as well as existent ones.

A. Rules of the reasoning system

We define some rules of model. Each rule functions as a user command on the reasoning system on a computer.

Rule 1 (Inform):* $\langle inform^*(w, t, \alpha, \beta, \varphi) \rangle$
 feasibility pre-condition: $B_\alpha\varphi \wedge \neg B_\alpha (Bif_\beta \varphi) \wedge C_{\alpha\beta}$,
 current time = t
 rational effect: $AXB_\beta\varphi$, current time = $t + 1$
 where $w \in W, t \in St_w, \alpha, \beta \in Agent$ and $\varphi \in P$.

Rule 2 (Add a communication channel):
 $\langle add_cc(t, \alpha, \beta) \rangle$
 feasibility pre-condition: $\neg C_{\alpha\beta}$, current time = t
 rational effect: $AXC_{\alpha\beta}$, current time = $t + 1$

Rule 3 (Delete a communication channel):
 $\langle del_cc(t, \alpha, \beta) \rangle$
 feasibility pre-condition: $C_{\alpha\beta}$, current time = t
 rational effect: $AX\neg C_{\alpha\beta}$, current time = $t + 1$
 We can use the above rules for given L_{CB} , Kripke model, and current time(state).

B. Syntax-sensitive rules

Now, we give rules for the following formulae:

- (a) $EXB_\alpha(\varphi \vee \psi)$ (b) $EXB_\alpha B_\beta(\varphi)$
- (c) $EXB_\alpha EX\varphi$ (d) $EX(B_\alpha\varphi \vee B_\beta\psi)$

For (a),(b),(c), and (d), we apply the following Rule 4, Rule 5, Rule 6, and Rule 7 to the model, respectively.

For the above case (a), we need to classify multiple valuations at the same state, that is, for tuple (φ, ψ) , we need to prepare the evaluations (true,true), (true,false), and (false,true) at the same time for each possible world. However, these multiple states cannot coexist at the same time in each possible world. To deal with this case, we supply new possible worlds by an increment of state. We define the following rule for this case.

Rule 4 (Communication with disjunction):

- (1): $\forall w \in W$, add a new state t' and R_w such that $tR_w t'$
- (2): $\forall w_n$ such that $(w_0, t, w_n) \in B_\alpha$, add $w_{n'}$ and $w_{n''}$, equalize states, temporal relation and valuation in w_n , $w_{n'}$ and $w_{n''}$.
- (3): Define $(w_0, t', w_{n'}) \in B_\alpha$ and $(w_0, t', w_{n''}) \in B_\alpha$, and for each w_m such that $(w_n, t, w_m) \in B_\alpha$, define $(w_{n'}, t, w_m) \in B_\alpha$ and $(w_{n''}, t, w_m) \in B_\alpha$.
- (4): Update a valuation such that $(w_n, t') \models \varphi \wedge (w_{n'}, t') \models \psi$, $(w_{n'}, t') \models \varphi \wedge (w_{n''}, t') \models \neg\psi$, and $(w_{n''}, t') \models \neg\varphi \wedge (w_{n''}, t') \models \psi$.

This rule is applied when a message includes a logical disjunction. The system evaluates the above formula (a) at state t in a possible world w_0 and performs the above procedures.

Rule 5 (Transfer of accessibility relation):

For $EX B_\alpha B_\beta(\varphi)$, A valuation is changed to satisfy that φ is consisted in the possible worlds of B_β -accessible world from the possible worlds of B_α -accessible world.

Rule 6 (Identification of structure):

In our reasoning system, for all possible worlds, we identify the tree structure of states with a temporal relation. Therefore, $EX B_\alpha \varphi \Leftrightarrow B_\alpha EX \varphi$.

Rule 7 (Distributive principle of modality):

In accordance with the semantics given in Section II-D, $(M, w, t) \models EX(\varphi \vee \psi) \Leftrightarrow (M, w, t) \models EX\varphi \vee EX\psi$.

Note that through Rule 4-7, all the formulae are reduced to the following form:

$$\underbrace{EX \cdots EX}_{n \text{ times}} B_\alpha \varphi.$$

Finally, we summarize the rule for those with the negative connective. As for $EX B_\alpha \neg\varphi$, we just need to change the truth value of φ in each newly-added state. In case $EX \neg B_\alpha \varphi$, we can prove if φ is true in every B_α -accessible world after the communication.

C. Decidability

In case there is no communication in agents, the proof of the veridity of a formula is same as the usual process. As a formula is decomposed into a finite number of subformulae and is reduced to a finite number of atomic propositions with

logical connectives, all these subformulae could be given truth values in finite steps.

In case a subformula includes a communication, that is, the subformula may be headed by multiple EX 's in front of $B_\alpha \varphi$. First, within the precondition of *inform** there is no communication. Thus, as far as the number of EX is finite, the veridicality of the precondition is judged in finite steps. Because the number of addition of new states in each world is equal to or less than the number of EX 's, if the number of possible worlds is finite then such addition of new states necessarily halts. Note that a new state is added according to the progress of time, i.e., the occurrence of communication in each world, so that there is no loop in each world.

IV. A MODEL CHECKER FOR CB_{CTL}

The emulator of L_{CB} was implemented in Prolog on Solaris 5.7, on SUNTM Sparc station Ultra 5-10. In this section, we show several results of the prover.

A formula $EX \cdots EX B_\alpha \varphi$ is evaluated false at a current time t , but would be also evaluated true at a current time $t' (> t)$. Our system, for an above case, evaluates a truth value and outputs a result in the future. Based on the disjunction in Section III-C, our system assesses inductively by using the following criteria.

Rule 8 (Model checking):

$(M, w, t) \models EX \cdots EX B_\alpha \varphi$ if each one of the channels $C_{\alpha_1 \alpha_2}, C_{\alpha_2 \alpha_3}, \dots, C_{\alpha_n \alpha}$, is true at t , $B_\alpha \varphi$ is true, and $\neg B_{\alpha_1}(Bif_{\alpha_2} \varphi) \wedge \cdots \wedge \neg B_{\alpha_n}(Bif_{\alpha} \varphi)$ is true.

Here, we show an example by using this rule for telephone game.

Example 1: Let $\alpha, \beta, \gamma \in Agent$, there is a communication channel from agent α to agent β , and also from agent β to agent γ . α has a belief φ . Then, will γ have a belief φ in the future?

To describe the above situation, we declare the following model:

- (1) $W = \{w_0, w_1, w_2, w_3, w_4\}$
- (2) $\forall w \in W, St_w = \{0\}$
- (3) $\forall w \in W, R_w = \emptyset$
- (4) $B_\alpha = \{(w_0, 0, w_1), (w_2, 0, w_1), (w_3, 0, w_1), (w_4, 0, w_1)\}$
- (5) $B_\beta = \{(w_0, 0, w_2), (w_0, 0, w_3), (w_1, 0, w_2), (w_1, 0, w_3), (w_4, 0, w_2), (w_4, 0, w_3)\}$
- (6) $B_\gamma = \{(w_0, 0, w_3), (w_0, 0, w_4), (w_1, 0, w_3), (w_1, 0, w_4), (w_2, 0, w_3), (w_2, 0, w_4)\}$
- (7) $L = \{(w_1, 0, \varphi), (w_3, 0, \varphi)\}$
- (8) $C = \{(w_0, 0, C_{\alpha\beta}), (w_1, 0, C_{\alpha\beta}), (w_2, 0, C_{\alpha\beta}), (w_3, 0, C_{\alpha\beta}), (w_4, 0, C_{\alpha\beta}), (w_0, 0, C_{\beta\gamma}), (w_1, 0, C_{\beta\gamma}), (w_2, 0, C_{\beta\gamma}), (w_3, 0, C_{\beta\gamma}), (w_4, 0, C_{\beta\gamma})\}$
- (8) current time = 0

In this situation, we get an answer that $(M, w_0, 0) \not\models EX B_\gamma \varphi$ and $(M, w_0, 0) \models EX EX B_\gamma \varphi$. And this model is

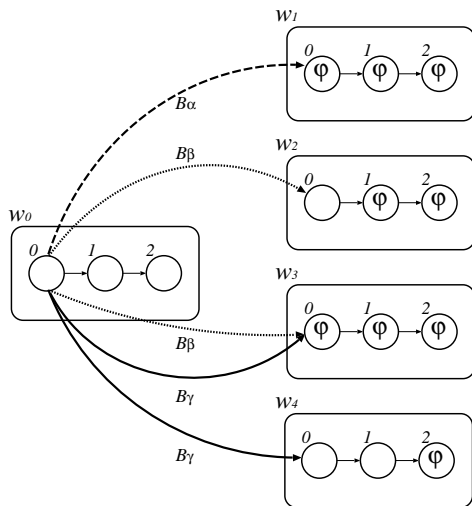

Fig. 1. Example of a telephone game

updated as follows:

- (2') For all $w \in W$, $St_w = \{0, 1, 2\}$
- (3') For all $w \in W$, $R_w = \{(0, 1), (1, 2)\}$
- (7') $L = \{(w_1, 0, \varphi), (w_3, 0, \varphi), (w_1, 1, \varphi), (w_2, 1, \varphi), (w_3, 1, \varphi), (w_1, 2, \varphi), (w_2, 2, \varphi), (w_3, 2, \varphi), (w_4, 2, \varphi)\}$

We show this situation in Fig.1.

V. DISCUSSION

We introduced CB_{CTL} and the reasoning system for it, based on temporal epistemic logic CTL. Because there has been no sound formalization of the modality U in the definition of *inform* in ACL/FIPA thus far, we did not include the modality in our logic in order to avoid fruitless complication. However, we can simply add U to our *inform** later when it is adequately introduced.

With regard to the existence of a reliable channel, we defined it as a proposition in the precondition of *inform**. Actually, the channel could be defined in such other ways as a modal operator, a higher-order meta-predicate, a background condition of inference, and so on. However, the definition by proposition seemed simplest as far as it did not affect belief operator, accessibility, and branching time of the logic; so that we adopted the current scheme.

We have used the term *update* of epistemic state when we splice a new state to a branching time path. Furthermore, in case of communication of $\varphi \vee \psi$, new possible worlds are provided. This view is based on the practical reason, that is, that the epistemic state could be changeable so as to satisfy the formula given as a query, accompanying a series of communications. Actually, what the prover does is to detect such a satisfiable path that is not explicitly mentioned at the time of query. Namely, one extreme view is that a new Kripke frame is given for each time step. However, in the strict view of modal logic, all the possible branching time can be regarded

to be given *a priori* immediately when a user declared a set of worlds, accessibility in them, and a set of communication channels.

We showed its decidability of the logic and implemented a model checker; if it is directly provable or if it could be validated through the chains of communications, the system returns the proof.

REFERENCES

- [1] A. E. Emerson and J. Srinivasan. Branching time temporal logic. In J. W. de Bakker, W. P. de Roever, and G. Rozenberg, editors, *Linear Time, Branching Time and Partial Order in Logics and Models for Concurrency*, pp. 123–172. Springer-Verlag, Berlin, 1989.
- [2] A. S. Rao & M. P. Gergeff. Decision procedure for BDI logics. *Journal of Logic and Computation*, Vol. 9, No. 3, pp. 293–342, 1998.
- [3] D. M. Gabbay, M. A. Reynolds, M. Finger. *Temporal Logic. Mathematical Foundations and Computational Aspects, Volume 2*, Clarendon Press, Oxford, 2000.
- [4] FIPA Foundation for Intelligent Physical Agents. Fipa 97 part 2 version 2.0: Agent communication language specification, 1997. <http://www.drogo.cse.it/fipa.org>.
- [5] J. Barwise and J. Seligman. *Information Flow. The Logic of Distributed Systems*, Cambridge University Press, New York, 1997.
- [6] M. Benerecetti, F. Giunchiglia and L. Serafini. Model Checking Multi-agent Systems. *Journal of Logic and Computation*, Special Issue “Computational and Logical Aspects of Multi-Agent Systems”, 8(3), pp. 401–423, 1998.
- [7] M. Colombetti. A commitment-based approach to agent speech acts and conversations. In *Proceedings of the Workshop on Agent Languages and Conversational Policies*, pp. 21–29, 2000.
- [8] M. Colombetti. Commitment-based semantics for agent communication languages. In *Proceedings of the First Workshop on the History and Philosophy of Logic, Mathematics and Computation (HPLMC00)*, Sansebastian, 2000.
- [9] M. Wooldridge and A. Rao. *Foundations of Rational Agency*. Applied Logic Series, Volume 14, Kluwer Academic Publishers, 1999.
- [10] M. Wooldridge. *Reasoning about Rational Agents*. MIT Press, Cambridge, 2000.
- [11] P. R. Cohen and H. J. Levesque. Rational interaction as the basis for communication. In P. R. Cohen, J. Morgan & M. E. Pollach, editors, *Intentions in Communication*, Chapter 8, pp. 221–255. MIT Press, Cambridge, 1990.