

# Fuzzy Logic Controlled Shunt Active Power Filter for Three-phase Four-wire Systems with Balanced and Unbalanced Loads

Ahmed A. Helal, Nahla E. Zakzouk, and Yasser G. Desouky

**Abstract**—This paper presents a fuzzy logic controlled shunt active power filter used to compensate for harmonic distortion in three-phase four-wire systems. The shunt active filter employs a simple method for the calculation of the reference compensation current based of Fast Fourier Transform. This presented filter is able to operate in both balanced and unbalanced load conditions. A fuzzy logic based current controller strategy is used to regulate the filter current and hence ensure harmonic free supply current. The validity of the presented approach in harmonic mitigation is verified via simulation results of the proposed test system under different loading conditions.

**Keywords**—Active power filters, Fuzzy logic controller, Power quality.

## I. INTRODUCTION

IN recent years, power quality distortion has become a serious problem in electrical power systems due to the increase of nonlinear loads drawing non-sinusoidal currents. Active filters have been widely used for harmonic mitigation as well as reactive power compensation, load balancing, voltage regulation, and voltage flicker compensation.

In three-phase four-wire systems with nonlinear loads a high level of harmonic currents in both the three line conductors and more significantly in the neutral wire has been enrolled. Unbalanced loads also results in further declination of the supply quality [1].

Various harmonic mitigation techniques have been proposed to reduce the effect of harmonics. These techniques include phase multiplication, passive filters, active power filters (APFs), and harmonic injection. One of the most popular APFs is the shunt active power filter. It is mainly a current source, connected in parallel with the non-linear loads. Conventionally, a shunt APF is controlled in such a way as to inject harmonic and reactive compensation currents based on calculated reference currents. The injected currents are meant

Ahmed A. Helal, is with the Arab Academy for Sciences and Technology and Maritime Transport, Alexandria, EGYPT (phone: 0020100173773; fax: 002035423336; e-mail: ahmedanas@ aast.edu).

Nahla E. Zakzouk is with the Arab Academy for Sciences and Technology and Maritime Transport, Alexandria, EGYPT (e-mail: nahlaezzeldin@hotmail.com).

Yasser G. Desouky is with the Arab Academy for Sciences and Technology and Maritime Transport, Alexandria, EGYPT (e-mail: ygdessouky@yahoo.com).

to cancel the harmonic and reactive currents drawn by the non-linear loads [2] as shown in fig. 1.

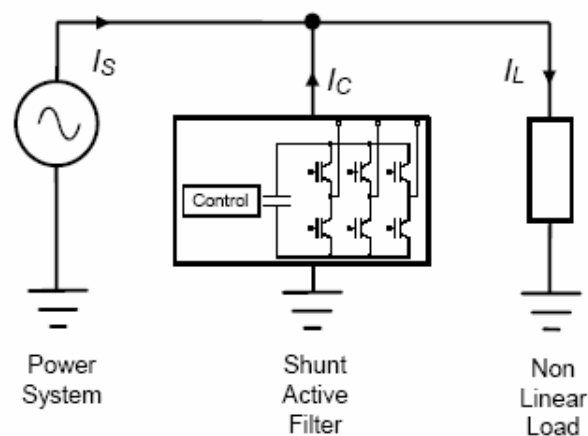

Fig. 1 Connection of shunt active filter with non-linear load

## II. CONTROL SYSTEM DESCRIPTION FOR SHUNT APF

### A. General

The control system for shunt APF could be divided into two main stages, in the first stage the reference compensating current has to be determined, while in the second stage the derivation of the switching function for the filter inverter circuit is computed [3].

### B. Reference Compensation Current Calculation

The reference compensation current is determined mainly using the information about both the fundamental and the harmonic content of the measured load current. Several methods have been proposed in the literature for reference compensation current computation [4]. These methods depend on either time domain or frequency domain analysis. In this paper the method utilized for reference compensation current calculation depends on Fast Fourier Transform (FFT), sort of frequency domain analysis. FFT used to extract the magnitude of the fundamental component of the load current from which the reference compensation current will be computed.

The following equations describe the procedure used for reference compensation current calculations;

$$i_{load} = i_{loadfund} + i_{harmonics} \quad (1)$$

$$i_{loadfund} = |i_{loadfund}| \sin \omega t \quad (2)$$

The load current is a periodic function and according to Fourier series;

$$i_{load} = \frac{a_0}{2} + \sum_{n=1}^{\infty} [a_n \cos(n\omega t) + b_n \sin(n\omega t)] \quad (3)$$

Where;

$$a_0 = \frac{1}{\pi} \int_{-\pi}^{\pi} i_{load}(t) dt, \quad (4)$$

$$a_n = \frac{1}{\pi} \int_{-\pi}^{\pi} i_{load}(t) \cos(nt) dt, \quad n \geq 0 \quad (5)$$

And

$$b_n = \frac{1}{\pi} \int_{-\pi}^{\pi} i_{load}(t) \sin(nt) dt, \quad n \geq 1. \quad (6)$$

Thus, the fundamental component magnitude of load current

$$|i_{loadfund}| = \sqrt{a_n^2 + b_n^2} \quad (7)$$

The amplitude of the reference supply current is given by;

$$|i_s^*| = |i_{loadfund}| + i_{dc} \quad (8)$$

Where  $i_{dc}$  is the current responsible for compensating of the dc losses due to the change in the dc capacitor voltage. Then taking the sine wave template from the supply voltage, the reference supply current will be;

$$i_s^* = (|i_{loadfund}| + i_{dc}) \sin \omega t \quad (9)$$

The reference compensating current is;

$$i_f^* = i_s^* - i_{load} \quad (10)$$

$$i_f^* = (|i_{loadfund}| + i_{dc}) \sin \omega t - (i_{loadfund} + i_{harmonics}) \quad (11)$$

$$i_f^* = i_{dc} \sin \omega t - i_{harmonics} \quad (12)$$

### C. Fuzzy Logic Current Controller

The desired switching signals for the filter inverter circuit are determined according to the error in the filter current using fuzzy logic controller.

The parameters for the fuzzy logic current controller used in this paper are as follow;

- The design uses centrifugal defuzzification method.
- There are two inputs; error and its derivative and one output, which is the command signal to the PWM of the filter inverter.
- The two input uses Gaussian membership functions while the output use triangle membership function.

Fig. 2 shows the degree of membership for the error and its

derivative and the command signal respectively.

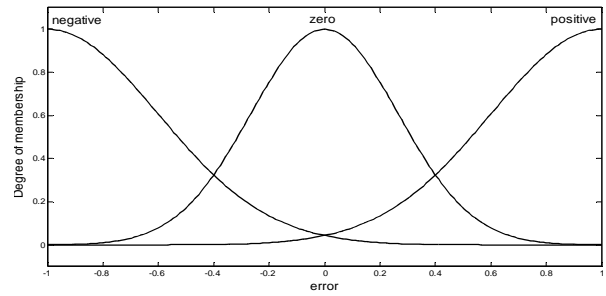

Fig. 2(a)

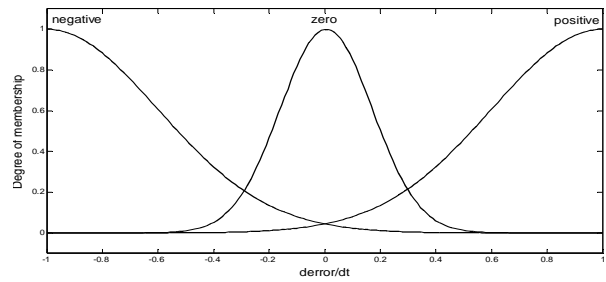

Fig. 2(b)

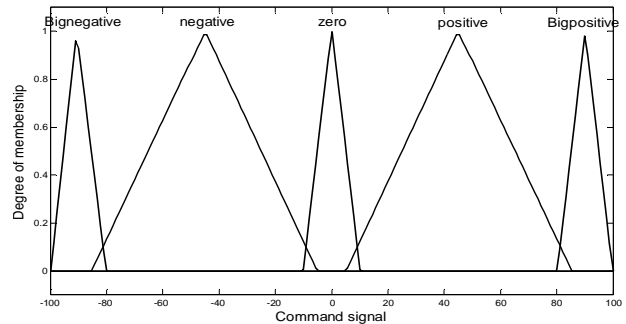

Fig. 2(c)

Fig. 2 The degree of membership for (a) the error, (b) the error derivative, and (c) the command signal

The above figures are the input and output variables for balanced load condition. Similar variable are used for unbalanced load condition but with different ranges; input 1 with range  $[-5,5]$ , input 2 with range  $[-1,1]$ , and the output with range  $[-250,250]$ . The fuzzy rules representation table is as follow;

TABLE I  
 THE FUZZY RULES REPRESENTATION TABLE

Error de/dt	Negative	Zero	Positive
Negative	Big Negative	Positive	Big Positive
Zero	Big Negative	Zero	Big Positive
Positive	Big Negative	Negative	Big Positive

The following figure summarizes the structure of the described control strategy for shunt APF.

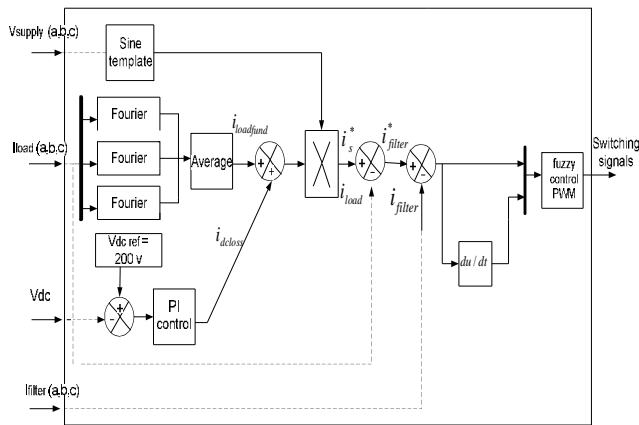

Fig. 3 The control strategy for shunt APF

### III. SIMULATION OF THE TEST SYSTEM SETUP

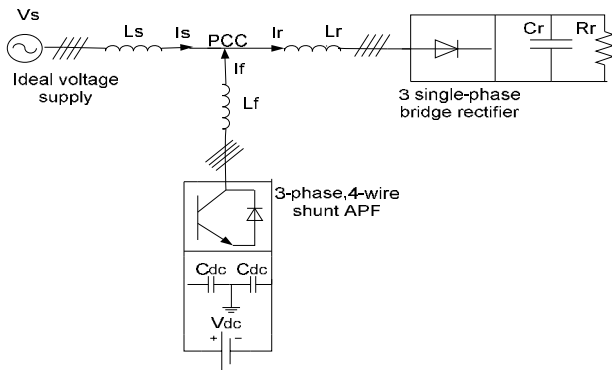

Fig. 4 the test system setup

The tested power system as shown above is a three-phase, four-wire 110V line voltage system supplying 600W to three single-phase balanced & unbalanced non linear loads with series passive filter reactance to be close to the source reactance [5]. The shunt APF is three-phase, four-wire IGBT-based current controlled voltage source converter with an output ac filter ( $L_f$ ) and energy storage capacitor on dc bus where;

$$C_{dc} = 350\mu\text{F}$$

$$V_{dc} = 200\text{volts}$$

The system was simulated using MATLAB/SIMULINK software in order to validate the efficiency of the presented control algorithm for both balanced and unbalanced load conditions.

#### A. Application of Shunt APF on Balanced Nonlinear Loads

In this case the load is in the form of 3 single-phase uncontrolled bridge rectifiers with R-C load.

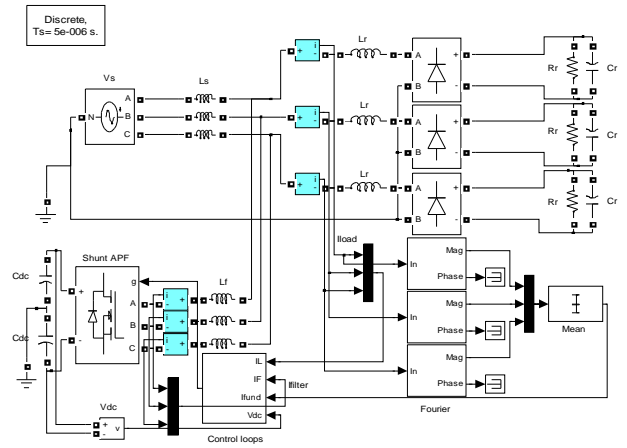

Fig. 5 The test system simulation with balanced nonlinear loads

The model parameters are as follows;

TABLE II  
 MODEL PARAMETERS IN CASE OF BALANCED LOAD

$L_s$	1 mH
$L_f$	4 mH
$L_r$	2 mH
Load	$R_r = 50 \Omega$ , $C_r = 1000 \mu\text{F}$

#### B. Application of Shunt APF on Unbalanced Nonlinear Loads

In this case the load is in the form of 3 single-phase different non linear loads. The first is uncontrolled bridge rectifier with R-C load, the second is pure resistive load & the third is bridge rectifier with R-C load.

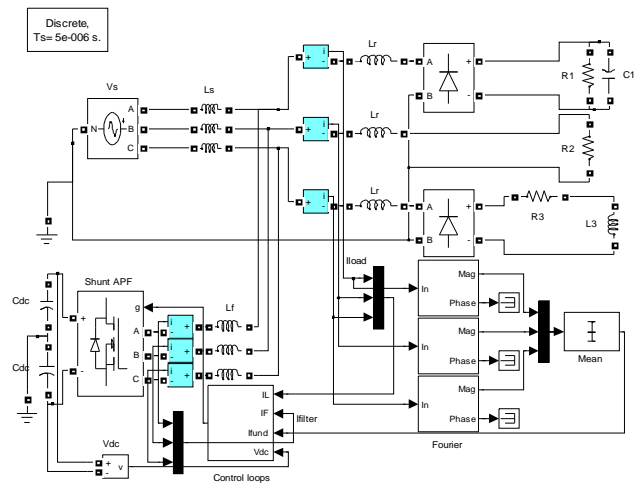

Fig. 6 The test system simulation with unbalanced nonlinear loads

The model parameters are as follows;

TABLE III  
 MODEL PARAMETERS IN CASE OF UNBALANCED LOAD

Ls	1 mH
Lf	3 mH
Lr	1.5 mH
Loads	<ul style="list-style-type: none"> <li>• Load1: R1= 80 <math>\Omega</math>, C1= 1000 <math>\mu</math>F</li> <li>• Load2: R2= 15 <math>\Omega</math></li> <li>• Load3: R3= 15 <math>\Omega</math>, L3= 0.1 H</li> </ul>

#### IV. SIMULATION RESULTS

##### A. Shunt APF with Balanced Nonlinear Loads

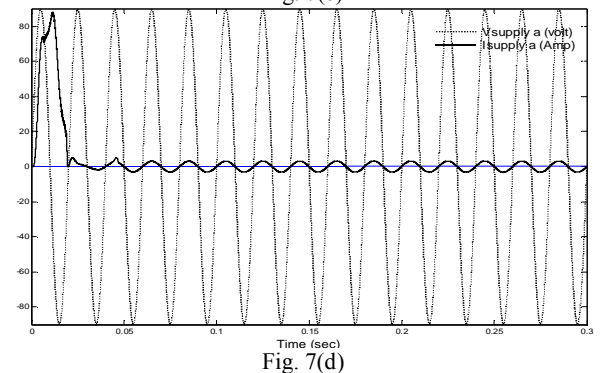
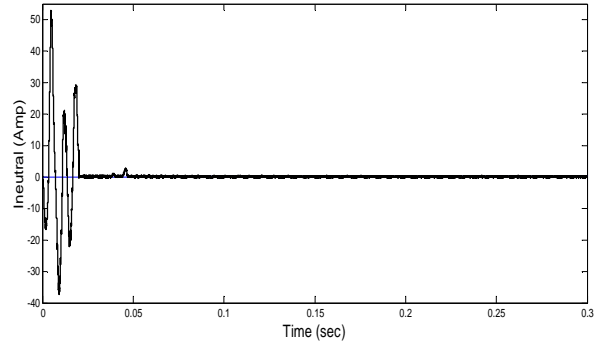
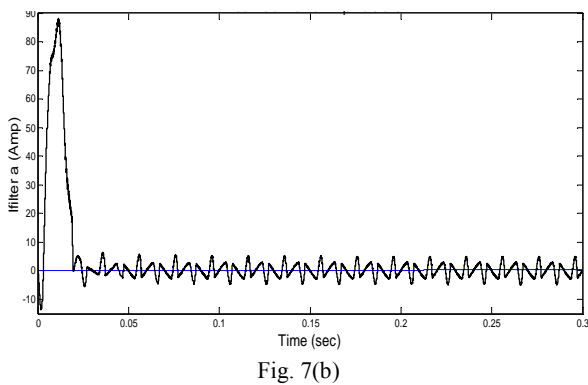
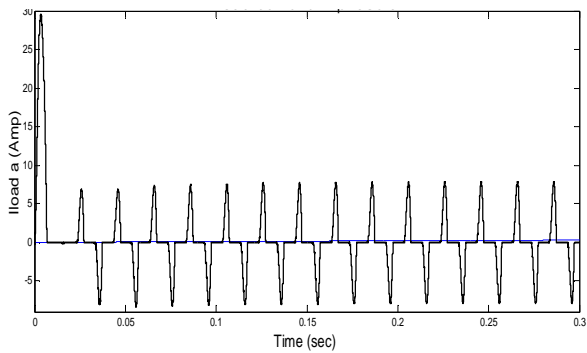
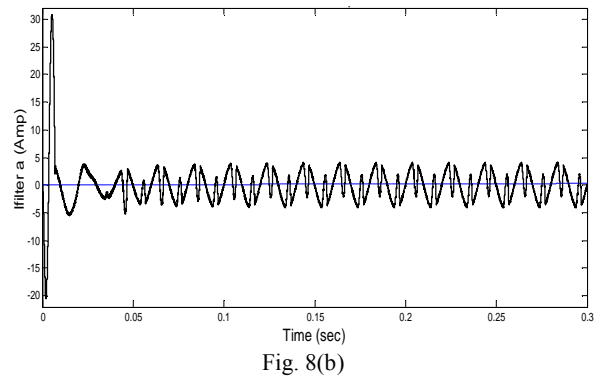
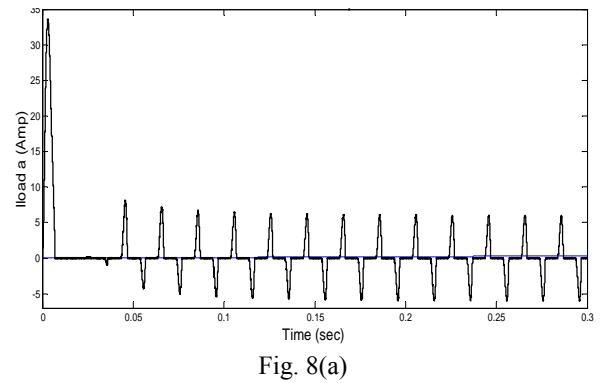

Fig. 7 The simulation results for (a) phase load current, (b) phase filter current, (c) neutral current, and (d) supply voltage and current

##### B. Shunt APF with Unbalanced Nonlinear Loads



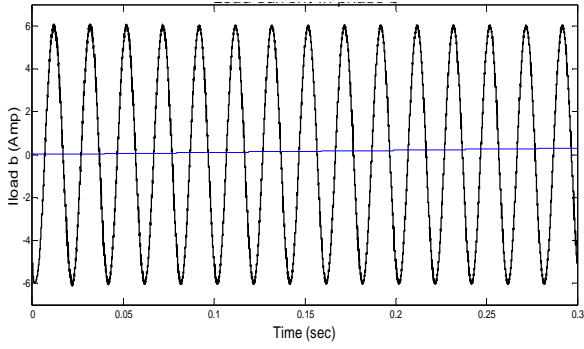

Fig. 8(c)

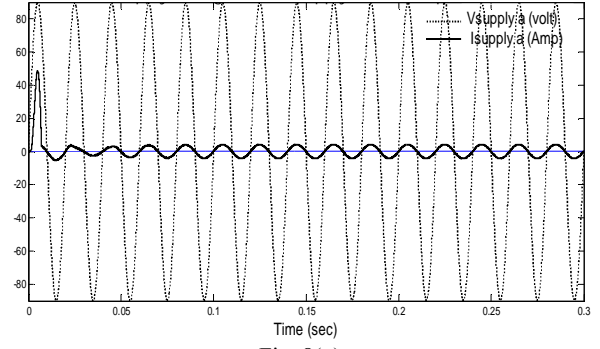

Fig. 8(g)

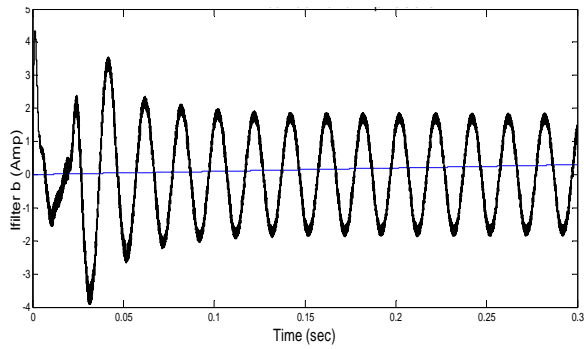

Fig. 8(d)

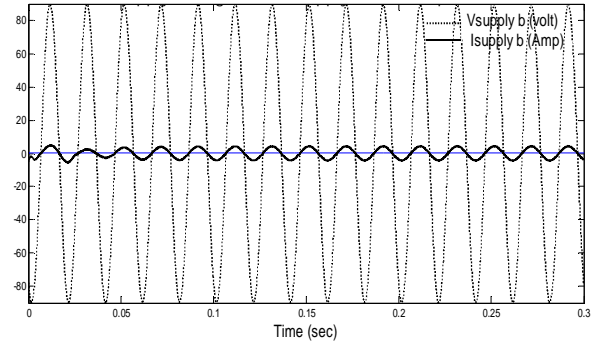

Fig. 8(h)

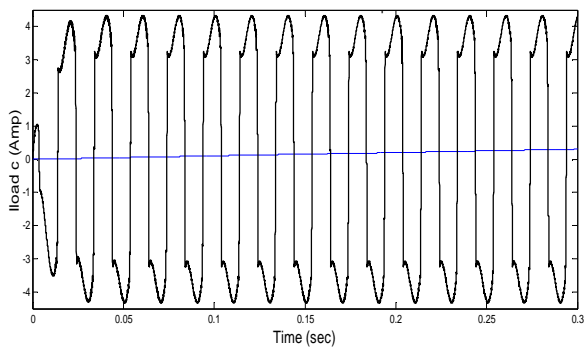

Fig. 8(e)

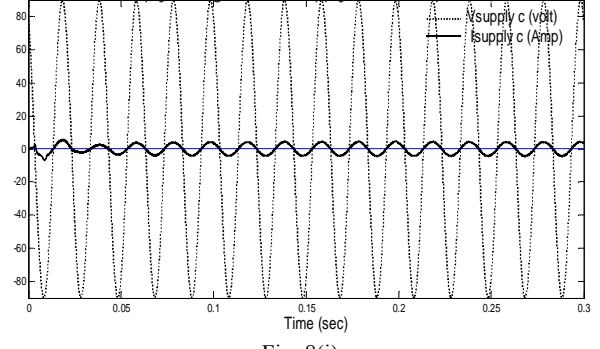

Fig. 8(i)

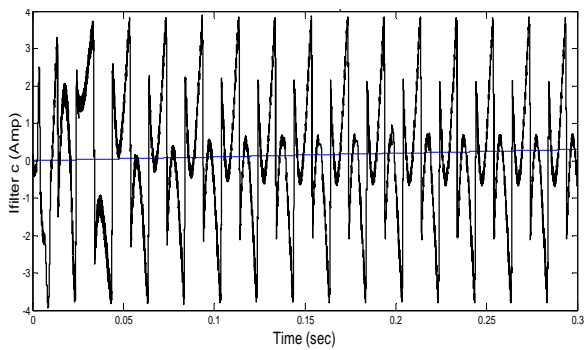

Fig. 8(f)

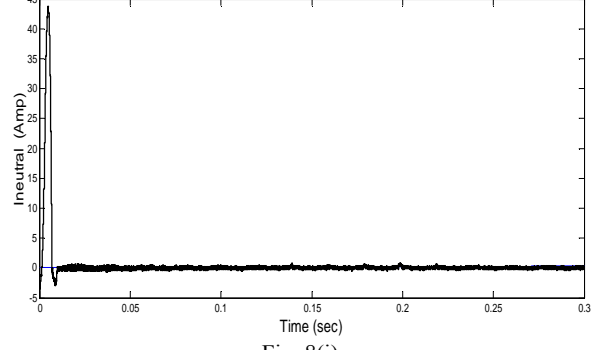

Fig. 8(j)

Fig. 8 The simulation results for (a) phase a load current, (b) phase a filter current, (c) phase b load current, (d) phase b filter current, (e) phase c load current, (f) phase c filter current, (g) phase a supply voltage and current, (h) phase b supply voltage and current, (i) phase c supply voltage and current, and (j) neutral current.

The simulation results for both balanced and unbalanced loading conditions prove the effectiveness of the designed active filter in both harmonic current mitigation and neutral current cancelation (in case of unbalanced loading).

#### V. CONCLUSION

A shunt APF based on FFT for reference compensating current calculation and fuzzy logic current controller has been studied to improve the system power quality by compensating the harmonic line currents and also the neutral current. FFT method is simple and reliable for reference compensating current calculations. Fuzzy logic controller improves the overall control system performance over other conventional controller. The validity of the presented control algorithm was proved by simulation of a three phase four wire test system under both balanced and unbalanced loading conditions.

#### REFERENCES

- [1] A. Elmitwally, S. Abdelkader, M. Elkateb "Performance evaluation of fuzzy controlled three and four wire shunt active power conditioners" IEEE Power Engineering Society Winter Meeting, 2000. Volume 3, Issue, 23-27 Jan 2000 Page(s):1650 - 1655 vol.3.
- [2] G. K. Singh, "Power system harmonics research: a survey" European Transactions on Electrical Power, 2009 Page(s):151 – 172.
- [3] A. Emadi, A. Nasiri, S. Bekiarov, *Uninterruptible Power Supplies and Active Filters*. CRC Press, 2005, ch. 2.
- [4] S. Rechka, E. Ngandui, Jianhong Xu; P. Sicard , "A comparative study of harmonic detection algorithms for active filters and hybrid active filters" IEEE 33rd Annual Power Electronics Specialists Conference, 2002. Volume 1, Page(s): 357 - 363.
- [5] J. S. Setiadji and H. H. Tumbelaka, "Simulation of Active Filtering Applied to A Computer Centre," Journal Technique Electro, vol. 2, pp 105-109, September 2002.

**Ahmed A. Helal** (M' 97) was born in Alexandria, Egypt, in 1972. He received the B.Sc. and M.Sc. degrees, both in electrical engineering, from Alexandria University, Alexandria, Egypt, in 1994 and 1998, respectively. He received the Ph.D. degree from Heriot-Watt University, Edinburgh, U.K., in 2004. He is currently Associate Professor in the Electrical and Control Engineering Department, Faculty of Engineering and Technology, Arab Academy for Sciences, Technology (AAST), Alexandria, Egypt. His areas of interest include electrical machine design, modeling, and simulation; power quality, and power electronics applications in power systems.