

Fuzzy Error Recovery in Feedback Control for Three Wheel Omnidirectional Soccer Robot

Vahid Rostami, Omid sojodishijani , Saeed Ebrahimijam, and Ali MohsenizanjaniNejad

Abstract—This paper is described one of the intelligent control method in Autonomous systems, which is called fuzzy control to correct the three wheel omnidirectional robot movement while it make mistake to catch the target.

Fuzzy logic is especially advantageous for problems that can not be easily represented by mathematical modeling because data is either unavailable, incomplete or the process is too complex. Such systems can be easily up graded by adding new rules to improve performance or add new features. In many cases , fuzzy control can be used to improve existing traditional controller systems by adding an extra layer of intelligence to the current control method. The fuzzy controller designed here is more accurate and flexible than the traditional controllers. The project is done at MRL middle size soccer robot team.

Keywords—Robocup , omnidirectional , fuzzy control, soccer robot , intelligent control .

I. INTRODUCTION

THE Robocup 2000 competition in Sydney, Australia proved that omni-directional mobile robot platforms are desirable for agility [2]. Many research groups are studying omni-directional mobile robots and vehicles. We decided to use a three - wheel drive because of the rich maneuverability and also due to the simple control. It is made up of the circle platform and three motors coupled to the Omni wheels are mounted with 120 degree between them, aligned like in an equilateral triangle so that their axis intersect at the robot center. In the center it can be seen the specially built encoders coupled to each motor axis. This configuration allows linear and angular speeds at the same time and this is of extreme importance for this team since each robot carries a fixed kicker. In Robocup MSL football games, the time a robot takes to reach the ball is of extreme importance. The faster it gets the ball the more chances it has to score a goal. With the 3 wheel drive configuration described in this paper a robot can move in a straight line all the time.

The inverse kinematics model is simple way to control such complicated system [3]. It was considered that the

representative coordinates of the robot were located in its centre.

The inverse kinematics equations for the mobile robot with respect to the mobile robot frame are shown below :

$$\begin{Bmatrix} \dot{\theta}_1 \\ \dot{\theta}_2 \\ \dot{\theta}_3 \end{Bmatrix} = \frac{1}{R} \begin{bmatrix} -\sin(\delta) & -\cos(\delta) & L_1 \\ -\sin(\delta) & \cos(\delta) & L_1 \\ 1 & 0 & L_2 \end{bmatrix} \begin{Bmatrix} \dot{x}_m \\ \dot{y}_m \\ \dot{\phi} \end{Bmatrix}$$

Fig. 1 Three omnidirectional conversion equation

Where $\{X'm, Y'm, \phi'm\}$ is the target Cartesian coordinate from the robot. And $\{\theta_1, \theta_2, \theta_3\}$ are wheel's velocities to get such target.

Also this inverse kinematics algorithm is a acceptable way to give wheel velocity but it is not accurate control for feedback control of the robot.

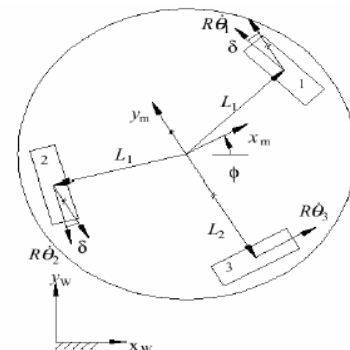

Fig. 2 Kinematics diagram of three wheel robot

So here a fuzzy controller is designed to cooperate with the inverse kinematics matrix for the best and accurate movement.

II. FEEDBACK CONTROL

Hence the feedback data show the behavior of the system while going through the target in three vectors . In order to do the job as well the designer had to analyze the data and give the appropriate inputs to the system . The action of collecting feedbacks, analyzing and giving new command is known as feedback control.

There are many methods of intelligence feedback control such as neural networks and fuzzy to control a electrical or mechanical machines . The well known one is PID controller which is used for years.

Authors are with Iran Islamic Azad University, Qazvin, Iran (phone: +982813665275 fax:+982813665279, zip code : 34185-1416, e-mails: Saeed.EbrahimiJam@gmail.com, Vh_rostami@qazviniau.ac.ir, O_sojudi@qazviniau.ac.ir, Mohseni.Z@gmail.com).

Traditional control systems like PID are based on mathematical models in which the control system is described using one or more differential equations that define the system response to its inputs. They are the products of decades of development and theoretical analysis, and are highly effective.

At first we design a PID controller because of simplification in Implementing but according to the results of the experiment we done , and the research of others [2] about such controllers we decided not to use it because,as can be seen from Figure 4 , the overshoot is approximately 10% for the X-Position and 5% for the Y Position , and the settling time is approximately 0.08 seconds. As shown in the bottom graph, the orientation fluctuates briefly while the robot moves to the desired position, but quickly returns to The desired value of 1.57 rad (90°).

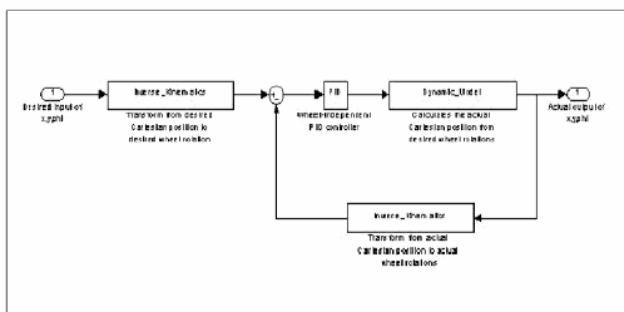

Fig. 3 Schematic diagram of PID controller

Such overshoots destroy the system fixture and generate enormous error in the high speeds.

III. AN OVERVIEW TO FUZZY CONTROL

Fuzzy control is a branch of fuzzy expert systems which has a fairly narrow purpose, process control, and is a highly developed field. Fuzzy logic control is being increasingly applied to solve control problems in areas where system complexity, development time and cost are the major issues. In the absence of a system mathematical model, a fuzzy system model is described which is analogous to a human operator's behavior, based on approximate reasoning bound by a minimum set of rules.

Fuzzy logic is specially advantageous for problems that cannot be easily represented by mathematical modeling because data is either unavailable, incomplete or the process is too complex. Linguistic modeling also leads to quick development cycles, easy programming, and accurate control.

Some studies have shown that FLS performance is more dependent on membership function design than rule base design[11]. Other studies have discussed rule base design [12] [13] [14] [15].

There are specific components characteristic of a fuzzy controller to support a design procedure which is mentioned as below:

1. Fuzzification : which converts each piece of input data to degrees of membership by a lookup in one or several membership functions .The fuzzification block thus matches

the input data with the conditions of the rules to determine how well the condition of each rule matches that particular input instance.

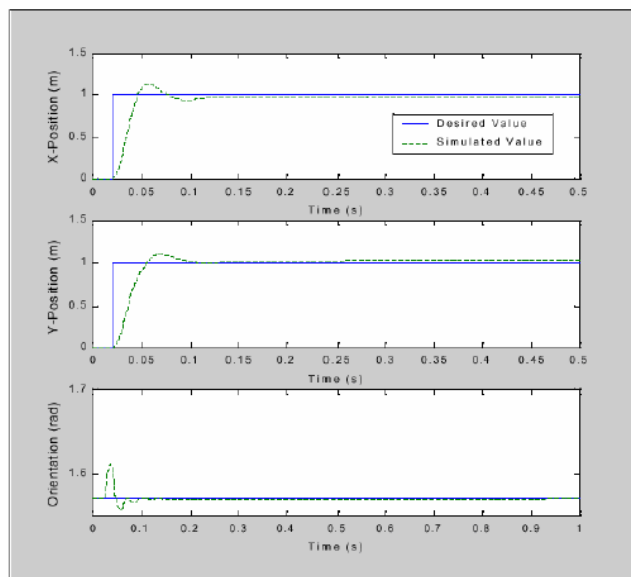

Fig. 4 Response of simulated control of PID

2. Rule base: Basically a linguistic controller contains rules in the IF-THEN format, but they can be presented in different formats. In many systems, the rules are presented to the end-user.

Membership function: Every element in the universe of discourse is a member of a fuzzy set to some grade, maybe even zero. The function that ties a number to each element x of the universe is called the **membership function $\mu(x)$** .

3. Defuzzification: The resulting fuzzy set must be converted to a number that can be sent to the process as a control signal.

$$u = \frac{\sum_i \mu(x_i) x_i}{\sum_i \mu(x_i)} \quad (1)$$

Center of gravity (COG): The crisp output value x is the abscissa under the centre of gravity of the fuzzy set, Here X_i is a running point in a discrete universe, and $\mu(X_i)$, is its membership value in the membership function. The expression can be interpreted as the weighted average of the elements in the support set. For the continuous case, replace the summations by integrals.

It is a much used method although it's computational complexity is relatively high. This method is also called **centroid of area** [9].

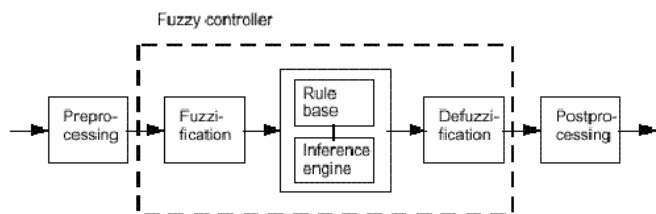

Fig. 5 Block of a fuzzy controller

IV. FUZZY FEEDBACK CONTROL MODEL OF ROBOT

According to the control block diagram, the system is also work with the inverse kinematics equation in the feedback.

It is used to simplify the robot movement calculation. In the next step the motion error is obtained and given to the fuzzy logic controller to determine which parameter of the system should change to recover the miss location of the robot.

In order to reduce the laptop PC operations, all the control algorithm and fuzzy controller were implemented on the multi processor Hard ware which is composed of four ATmel microcontrollers (one for fuzzy and kinematics algorithm control and the others for driving wheels)[7].

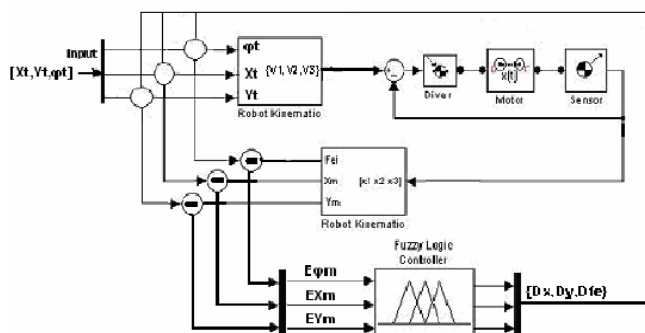

Fig. 6 Fuzzy control block diagram of the robot

V. GENERATING THE FUZZY MEMBERSHIP FUNCTIONS

According to the algorithm (Fig. 6) a MIMO fuzzy controller need to be designed to cover all the situations.

The most common shape of membership functions is triangular, which we used, but the shape is generally less important than the number of curves and their placement.

The inputs into the fuzzy knowledge base are now variables EX, EY and EØ. Fig. 7 shows the fuzzy input sets used for each variable.

There are seven linguistic membership sets defined for each variable. For all variables EX, EY and EØ: NH stand for Negative High, NM is Negative Middle, NS is Negative Small, Z is Zero, PS is Positive Small, PM is Positive Middle and PS is Positive High. Hence:

$$EX = X(\text{input}) - X(\text{feedback}) \quad (2)$$

$$EY = Y(\text{input}) - Y(\text{feedback}) \quad (3)$$

$$E\phi = \phi(\text{input}) - \phi(\text{feedback}) \quad (4)$$

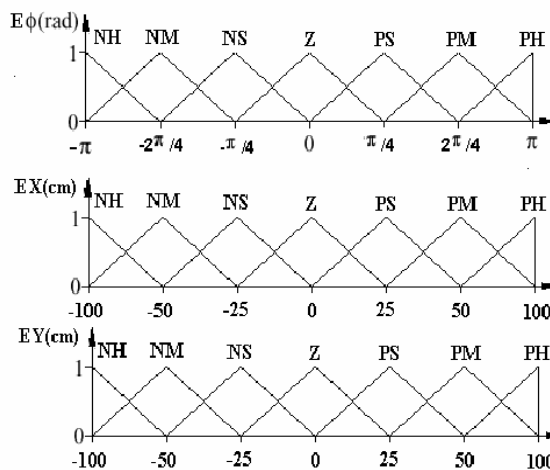

Fig. 7 Fuzzy input diagram

These variables are the error given to fuzzy controller to determine about the robot movement in the next step where EX is error in X vector, EY is in Y vector and the EØ is for rotational error.

The domains were defined from -100 to 100 because the commands in X and Y are not greater than one meter. and the rotation angle is from -180 to 180 degree.

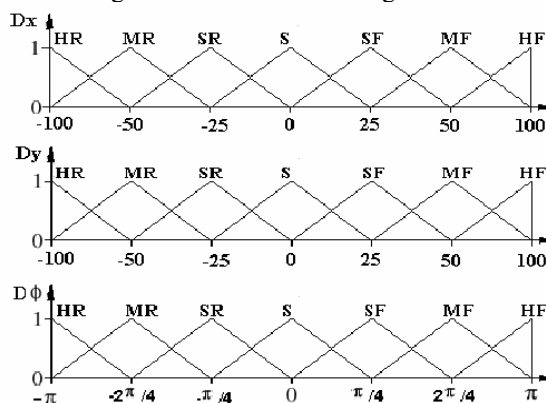

Fig. 8 Fuzzy output diagram

For the output: HR is High Reverse, MR is Medium Reverse, SL is Small Reverse, S is Stationary, SF is Small Forward, MF is Medium Forward and HF is High Forward, which display the parameters of next step movement of the robot. DX is the value which should give to convert matrix for error recovery in X-Vectors, DY for Y-Vectors and DØ for rotational error.

In all there are now $7^3 = 343$ rules in a complete fuzzy knowledge base for this system. A maximum of 2^3 rules fire for any input into the fuzzy controller.

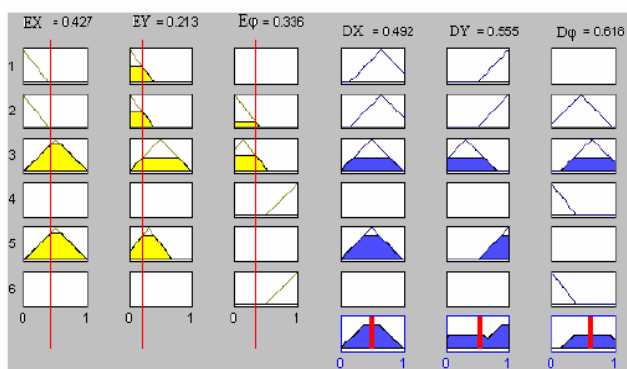

Fig. 9 Simulated rules with matlab

Given a fuzzy rule base with M rules, a fuzzy controller as given uses a singleton fuzzifier, Mamdani product inference engine, and centre of gravity defuzzifier to determine output variables.

A special feature of overlapping sets using the Mamdani product inference engine is that a minimum of one and a maximum of two membership sets for each input variable will fire [5]. The Rule Base Table of the Inference engine in this system is 3D.

VI. CONCLUSION

By developing this controller the overshoot decreases to much better than PID in each vector and control is much accurate and flexible in comparing with PID controllers.

VII. DISCUSSION

Also the fuzzy control is advantageous method in modern control but there are many ways to upgrade it. One of them is to make that intelligent by adding a Neural Networks. This is called Nero-fuzzy system. Such systems are as intelligent to make their selves compatible with the environmental conditions and learn through them. According to the new approaches most of the control system will change to Nero-fuzzy in the future. The next step in this project is to make this control algorithm more intelligent by using Nero-fuzzy system. It gave the robot such capability to learn from the field of play before the game started. So that in this case the error recovery is much more flexible.

Imagine that the robot is commanded to go (X, Y, \emptyset) but it caught to (X', Y', \emptyset') . here the error is learned by the NN and it tries to make the output as near to the input. This is done under the supervision of the fuzzy neuron layers.

ACKNOWLEDGEMENT

The Author would like to thank to Dr. M. Mousakhani (chief of Qazvin Azad University) and Dr. A. M. Shahri (chief of MRL) for their supports.

REFERENCES

- [1] Lotfi . Zadeh "theory of Fuzzy sets" 1965 university of California-Berkeley.
- [2] B.carter , M.Good,M . Dorohoff , J.Lew, R.L. WilliamsII,Paolo Gallina "Mechanical Design and Modeling of an Omni-directional Robocup Player" Department of mechanical Engineering Ohio University, USA2002

- [3] F.Riberio,I.Moutinho,P.silva,C.fraga,N.pereira "THREE OMNI-DIRECTIONAL WHEELS CONTROL ON A MOBILE ROBOT "Control 2004,University of bath, UK, September 2004 [4] Rock Hampton,QLD 4702,Australia
- [4] M.Mohammadian & R.J.Stonier." Fuzzy Rule Generation by Genetic Learning for Target Tracking", Proceeding of the 5th International intelligent Systems Conference , Reno ,Nevada, 10-14 June,1996
- [5] P.J Thomas,R.J Stonier "Fuzzy control in robot soccer evolutionary learning in the first layer of control " Faculty of Informatics and communication ,Central Queensland University.
- [6] Tapio Frantti "Timing of fuzzy membership functions from data "Department of process and Environmental Engineering , ISBN 951-42-6434-7 ,ISSN 0355-3213 University of Oulu Press 2001.
- [7] Navin Govind "Fuzzy Logic Control with the Intel 8xc196 Embedded Microcontroller " Intel Corporation Chandler, AZ.
- [8] E.H.Mamdani and S.Assilian, An Experiment in Linguistic synthesis with a Fuzzy Logic Controller ,Fuzzy Reasoning and it's Applications ,Academic Press,1981.
- [9] B.Ravindran, P.Kachroo and T.Hegezay "Intelligent Feedback control-Based adaptive resource Management for Asynchronous , Decentralized Real Time Systems" Virginia polytechnic Institute and state university.
- [10] Wei,Xinjiang Yantai Normal Univ.Jing,Yuanwei & Zhao ,Jun Northeastern Univ." Robust Adaptive Fuzzy Controller for MIMO nonlinear Systems" American Control Conference 2005.
- [11] O.Cordon , F.Herrera, L.Magdalena and P.Villar "A Genetic Learning Process for Scaling Factors, Granularity and Contexts of the Fuzzy Rule-based System Data Base Information Sciences" 136(2001)85-107.
- [12] G.Procyk & E.Mamdani,"A Linguistic Self-Organizing Process Controller "Automatica 15(1979)15-30.
- [13] P.Xian-Tu, Generating Rules for Fuzzy Logic Controllers by Functions Fuzzy Sets and Systems 36(1990)83-89.
- [14] D.Simon "Sum Normal Optimization of Fuzzy Membership Function " International Journal of Uncertainty, Fuzziness and Knowledge - Based Systems VOL.0,No,0(1993)World Scientific Publishing Company Revised January 28, 2002.