

The invariant properties of two-port circuits

Alexandr A. Penin

Abstract—Application of projective geometry to the theory of two-ports and cascade circuits with a load change is considered. The equations linking the input and output of a two-port are interpreted as projective transformations which have the invariant as a cross-ratio of four points. This invariant has place for all regime parameters in all parts of a cascade circuit. This approach allows justifying the definition of a regime and its change, to calculate a circuit without explicitly finding the a -parameters, to transmit accurately an analogue signal through the unstable two-port.

Index Terms—circuit regime, geometric circuit theory, projective geometry, two-port.

I. INTRODUCTION

THE theory of two-port circuits is widely used for the analysis of linear electric circuits. It is convenient to use the methods of projective geometry in the case of a load's change in a wide range. It allows visually establishing the relationship between the various parameters of regime for individual parts of cascade connection of two-port circuits. In particular, this approach justifies the definition of the regime in the relative view (relative to these characteristic regimes as an open circuit OC and a short circuit SC). Also, it allows comparing the regimes of the different circuits.

In projective geometry, corresponding expressions define mapping between the elements of one-dimensional manifolds, such as direct lines. In this case, the invariant properties such maps or projective transformations are become apparent. Thus, if there is a value equal to all parts of the circuit or network, it is presents of interest to the theory of two-port and may be useful in practice. This paper presents the results obtained earlier by the author.

II. THE PROJECTIVE TRANSFORMATIONS IN THE CASCADE CIRCUIT

Let we consider a cascade connection of the two two-port $TP1$ and $TP2$ with the changeable conductivity or resistance of the load within a wide range on Fig. 1. Load characteristics or load lines for all parts or sections of the circuit can be calibrated in corresponding values of conductivity, current or voltage. The Fig. 1 shows there is the specified mapping a load characteristics of different sections to each other, which it is conditionally shown dashed lines.

Let the conductivity of the load Y_{H2} be changed from the value Y_{H2}^1 to the value Y_{H2}^2 , i.e. a changing of the load or of the parameters of regime is defined by the length of the segment $Y_{H2}^2 Y_{H2}^1$. This change determines the correspond changes of the conductivity Y_{H1} and Y_{H0} . It may be noted

A.A. Penin is with the Institute of electronic engineering and industrial technologies, Academy of Sciences of Moldova, e-mail: aapenin@mail.ru
 Manuscript received August 24, 2009; revised November 11, 2009.

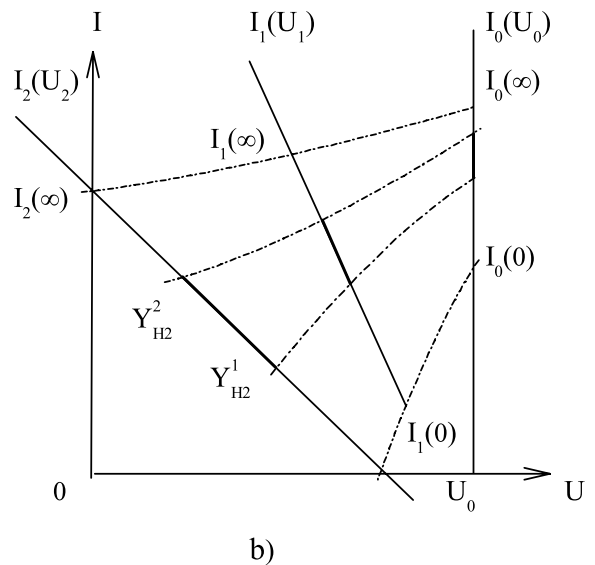
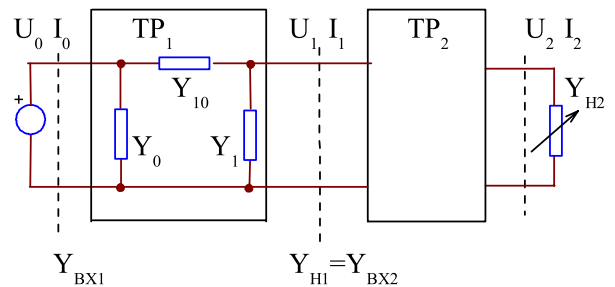

Fig. 1. A cascade connection of the two two-port with the changeable conductivity of the load

that the length of segments for all the load lines is different for the usually used Euclidean geometry. However, if the mapping is viewed as a projective transformation (in the sense of projective geometry), the invariant, a cross-ratio of four points, is performed, which defines the same length of segments.

The entire circuit regarding load Y_{H2} represents an active two-pole or an equivalent generator. The demonstration of the projective geometry and the definition of regimes of

the equivalent generators are considered in [1], [2]. In this regard, let us use and complement the definitions valid for the cascade circuit:

- Regime of a circuit is a point (the work point) with a specified (projective) coordinate on the load characteristics and coordinate axes;
- Change of the regime is a movement of a point for all characteristics, which determines the segments with corresponding length;
- There is an independence or invariance of the regime and its changes to the parts of a circuit.

III. PROJECTIVE CONFORMITY OF THE INPUT-OUTPUT OF A TWO-PORT

Let us consider the first asymmetrical two-port *TP1* and give the necessary expressions. We use the specific values of elements for visibility and dimensions of values are not indicated for simplifying of the record. As it is known, equation *TP1* through the *Y* - parameters or parameters of conductivity, taking into account the directions of currents has the form [3]:

$$\begin{pmatrix} I_1 \\ -I_0 \end{pmatrix} = \begin{pmatrix} -Y_{11} & Y_{10} \\ Y_{01} & Y_{00} \end{pmatrix} \cdot \begin{pmatrix} U_1 \\ U_0 \end{pmatrix}$$

where:

$$Y_{00} = Y_{10} + Y_0 = 5, Y_{11} = Y_{10} + Y_1 = 6.4, Y_{10} = Y_{01} = 4$$

The determinant of the *Y* -matrix is:

$$\Delta = Y_{00}Y_{11} - Y_{01}Y_{10} = 16, \sqrt{\Delta} = 4$$

The characteristic conductance of *TP1* to the input and output is:

$$Y_{BX1.C} = \sqrt{\frac{Y_{00}}{Y_{11}}\Delta} = 3.535, \quad Y_{H1.C} = \sqrt{\frac{Y_{11}}{Y_{00}}\Delta} = 4.525$$

It is also known that the equation of the *TP1* through *a* -parameters or transmission parameters is as follows:

$$\begin{aligned} \begin{pmatrix} U_0 \\ I_0 \end{pmatrix} &= \begin{pmatrix} a_{11} & a_{12} \\ a_{21} & a_{22} \end{pmatrix} \cdot \begin{pmatrix} U_1 \\ I_1 \end{pmatrix} = \\ &= \begin{pmatrix} 1.6 & 0.25 \\ 4 & 1.25 \end{pmatrix} \cdot \begin{pmatrix} U_1 \\ I_1 \end{pmatrix} \end{aligned} \quad (1)$$

where:

$$a_{11} = \frac{Y_{11}}{Y_{10}}, a_{12} = \frac{1}{Y_{10}}, a_{21} = \frac{\Delta}{Y_{10}}, a_{22} = \frac{Y_{00}}{Y_{10}}$$

The inverse expression has the form:

$$\begin{aligned} \begin{pmatrix} U_1 \\ I_1 \end{pmatrix} &= \begin{pmatrix} a_{22} & -a_{12} \\ -a_{21} & a_{11} \end{pmatrix} \cdot \begin{pmatrix} U_0 \\ I_0 \end{pmatrix} = \\ &= \begin{pmatrix} 1.25 & -0.25 \\ -4 & 1.6 \end{pmatrix} \cdot \begin{pmatrix} U_0 \\ I_0 \end{pmatrix} \end{aligned}$$

The determinant of the *a* -matrix is:

$$\Delta_a = a_{11}a_{22} - a_{12}a_{21} = 1$$

This feature of the *a* -parameters allows entering the hyperbolic functions:

$$\Delta_a = \cosh^2 \gamma - \sinh^2 \gamma = 1$$

where: γ is an attenuation coefficient.

Then the equation of the *TP1* is given by:

$$\begin{pmatrix} U_0 \\ \bar{I}_0 \end{pmatrix} = \begin{pmatrix} \cosh \gamma & \sinh \gamma \\ \sinh \gamma & \cosh \gamma \end{pmatrix} \cdot \begin{pmatrix} U_1 \bar{Y}_{H.C} \\ \bar{I}_1 \end{pmatrix} \quad (2)$$

where:

$$\bar{I}_0 = \frac{I_0}{Y_{BX.C}}, \bar{Y}_{H.C} = \frac{Y_{H.C}}{\sqrt{\Delta}}, \bar{I}_1 = \frac{I_1}{\sqrt{\Delta}}$$

In turn, the conductivities at the input and output are connected already by the linear- fractional expression according to (1):

$$\begin{aligned} Y_{BX1} &= \frac{I_0}{U_0} = \frac{a_{22}Y_{H1} + a_{21}}{a_{12}Y_{H1} + a_{11}} = \\ &= \frac{1.25Y_{H1} + 4}{0.25Y_{H1} + 1.6} \end{aligned} \quad (3)$$

This expression in a normalized form takes the form according to (2):

$$\frac{Y_{BX1}}{Y_{BX1.C}} = \frac{\tanh \gamma + Y_{H1}/Y_{H1.C}}{1 + (\tanh \gamma)Y_{H1}/Y_{H1.C}} \quad (4)$$

where:

$$\tanh \gamma = 1/\sqrt{2} = 0.707$$

Now, consider the second *TP2*. Let it be symmetrical with the specific parameters. Then, similar to expressions (1), (3) we get:

$$\begin{pmatrix} U_1 \\ I_1 \end{pmatrix} = \begin{pmatrix} 1.25 & 0.25 \\ 2.25 & 1.25 \end{pmatrix} \cdot \begin{pmatrix} U_2 \\ I_2 \end{pmatrix} \quad (5)$$

The inverse expressions have the forms:

$$\begin{pmatrix} U_2 \\ I_2 \end{pmatrix} = \begin{pmatrix} 1.25 & -0.25 \\ -2.25 & 1.25 \end{pmatrix} \cdot \begin{pmatrix} U_1 \\ I_1 \end{pmatrix},$$

$$Y_{BX2} = \frac{I_1}{U_1} = \frac{1.25Y_{H2} + 2.25}{0.25Y_{H2} + 1.25} \quad (6)$$

The condition of the given cascade circuit is performed:

$$Y_{H1} = Y_{BX2}.$$

A concrete mapping of the load characteristics for $U_0 = 10$ is drawn on Fig. 2. Let the conductivity Y_{H2} be equal to the extreme values $Y_{H2}(0) = 0, Y_{H2}(\infty) = \infty$. The

corresponding values of conductivities Y_{H1}, Y_{BX1} according to (6), (3) are:

$$Y_{H1}(0) = 1.8, \quad Y_{H1}(\infty) = 5,$$

$$Y_{BX1}(0) = 3.048, \quad Y_{BX1}(\infty) = 3.595.$$

Next, we find the values of current I_0 :

$$I_0(0) = Y_{BX1}(0) \cdot U_0, \quad I_0(\infty) = Y_{BX1}(\infty) \cdot U_0.$$

We find the values of currents

$$I_1(0) = 8.78, \quad I_1(\infty) = 17.54,$$

$$I_2(0) = 0, \quad I_2(\infty) = 14.03$$

and voltages

$$U_1(0) = 4.88, \quad U_1(\infty) = 3.51,$$

$$U_2(0) = 3.89, \quad U_2(\infty) = 0$$

using the inverse expressions (1), (5). The projective

T		T'			
$Y_{H2}(0)$	$Y_{H2}^2(0)$	$Y_{H2}(P_{2M})$	Y_{H2}^1	$Y_{H2}^2(\infty)$	
0	1.073	3.597	10.41	∞	Y_{H2}
0	3.22	7.016	10.41	14.03	I_2
3.89	$U_2^2=3$	1.95	$U_2^1=1$	0	U_2
8.78	10.8	13.15	15.28	17.54	I_1
4.88	4.56	4.2	3.86	3.51	U_1
Y_{H1}^2		Y_{H1}^1			Y_{H1}
1.8	2.37	3.14	3.96	5	
30.48	31.75	33.22	34.55	35.95	I_0
m^2		m^1			m
0	0.298	1	2.89	∞	

Fig. 2. A concrete mapping of the load characteristics

mapping or transformation is defined by three pairs of points [4]. Therefore, in addition to these two extreme points, it is convenient as the third or the unit (or scale) to use the point of maximum power P_{2M} of the load Y_{H2} . In this case:

$$\text{current } I_2(P_{2M}) = I_2(\infty)/2 = 7.016,$$

$$\text{voltage } U_2(P_{2M}) = U_2(0)/2 = 1.95,$$

$$\text{and } Y_{H2}(P_{2M}) = 3.597.$$

Next, we find the corresponding values of currents, voltages at the remaining parts of the circuit. Let the initial regime of the circuit (point 'i' on the all load characteristics) be set by the voltage of the load $U_2^1 = 1$. Let us calculate the values of all currents, voltages, conductivities at the remaining parts of the circuit. In terms of projective geometry the voltages and currents are homogeneous coordinates, and conductivities are heterogeneous. The idea is that the homogeneous coordinates always have a finite value. The projective coordinate of a point 'i' at all lines is defined by cross-ratio m^1 of four points and takes the same value. We have for the part or terminals of load Y_{H2} :

$$m^1(Y_{H2}) = (Y_{H2}(0) Y_{H2}^1 Y_{H2}(P_{2M}) Y_{H2}(\infty)) =$$

$$= \frac{Y_{H2}^1 - Y_{H2}(0)}{Y_{H2}^1 - Y_{H2}(\infty)} \div \frac{Y_{H2}(P_{2M}) - Y_{H2}(0)}{Y_{H2}(P_{2M}) - Y_{H2}(\infty)} =$$

$$= \frac{Y_{H2}^1}{Y_{H2}(P_{2M})} = \frac{10.41}{3.597} = 2.89, \quad (7)$$

$$m^1(U_2) = (U_2(0) U_2^1 U_2(P_{2M}) U_2(\infty)) =$$

$$= \frac{U_2^1 - U_2(0)}{U_2^1 - U_2(\infty)} \div \frac{U_2(P_{2M}) - U_2(0)}{U_2(P_{2M}) - U_2(\infty)} =$$

$$= \frac{1 - 3.89}{1 - 0} \div \frac{1.95 - 3.89}{1.95 - 0} = 2.89 \div 1 = 2.89, \quad (8)$$

$$m^1(I_2) = (I_2(0) I_2^1 I_2(P_{2M}) I_2(\infty)) =$$

$$= \frac{I_2^1 - I_2(0)}{I_2^1 - I_2(\infty)} \div \frac{I_2(P_{2M}) - I_2(0)}{I_2(P_{2M}) - I_2(\infty)} =$$

$$= \frac{10.41 - 0}{10.41 - 14.03} \div \frac{7.016 - 0}{7.016 - 14.03} = 2.89 \div 1 \quad (9)$$

We have for the part or terminals of the load Y_{H1} :

$$m^1(Y_{H1}) = (Y_{H1}(0) Y_{H1}^1 Y_{H1}(P_{2M}) Y_{H1}(\infty)) =$$

$$= \frac{3.96 - 1.8}{3.96 - 5} \div \frac{3.14 - 1.8}{3.14 - 5} = 2.89, \quad (10)$$

$$m^1(U_1) = (U_1(0) U_1^1 U_1(P_{2M}) U_1(\infty)) =$$

$$= \frac{3.86 - 4.88}{3.86 - 3.51} \div \frac{4.2 - 4.88}{4.2 - 3.51} = 2.89 \div 1 \quad (11)$$

$$m^1(I_1) = (I_1(0) I_1^1 I_1(P_{2M}) I_1(\infty)) =$$

$$= \frac{15.28 - 8.78}{15.28 - 17.54} \div \frac{13.15 - 8.78}{13.15 - 17.54} = 2.89 \div 1 \quad (12)$$

For the current I_0 is:

$$m^1(I_0) = (I_0(0) I_0^1 I_0(P_{2M}) I_0(\infty)) = (30.48 \quad 34.55 \quad 33.22 \quad 35.95) = 2.89 \div 1$$

Thus, the invariant property of cross-ratio is performed, because the projective transformations are defined by linear-fractional expression like (3). These invariant relations in all parts of cascade circuit define the original "principle of conformity of regimes".

Therefore, the definition of regime by cross-ratio (7) - (12) removes the indeterminateness in the choice of possible relative expressions across all parameters and parts of a circuit. The value of the cross-ratio is not changed if to divide or to normalize all members by the same value. For example, the normalized value to the load Y_{H2} will be $Y_{H2}(P_{2M})$, and the normalized value to the voltage U_2 will be $U_2(0)$.

In turn, a special case of a cross-ratio, an affine ratio of three points or usual proportion is for the currents and voltages. This follows from the fact that for those already homogeneous coordinates, the transformation is a linear type (1), corresponding to affine transformation or affine geometry.

The first and the second fractions for the currents and voltages for all parts are equal among themselves due to the implementation of proportion. Thus, the affine transformation is defined by two pairs of corresponding points. Therefore, if we use only the currents and voltages one can use an invariant in the form of an affine ratio.

Conversion (2) is characterized also by another invariant. This expression for the symmetric TP takes the form:

$$\begin{pmatrix} U_0 \\ I_0\sqrt{\Delta} \end{pmatrix} = \begin{pmatrix} \cosh \gamma & \sinh \gamma \\ \sinh \gamma & \cosh \gamma \end{pmatrix} \cdot \begin{pmatrix} U_1 \\ I_1\sqrt{\Delta} \end{pmatrix}$$

This transformation can be seen as a rotation of the radius-vector OY_H of constant length at the angle γ to the position OY_{BX} in the pseudo-Euclidean space I, U on Fig. 3. Then the invariant is given by the expression:

$$U_1^2 - I_1^2\Delta = U_0^2 - I_0^2\Delta$$

and ones is the length of the vector OY_H .

This approach corresponds to the Lorentz transformations in the mechanics of the relative motion. In turn, (4) corresponds to the rule of addition of relativistic velocities [5].

Let the regime of the circuit be changed (the point 'f' at all the load characteristics), so that the load voltage is $U_2^2 = 3$. Let us calculate similarly all values and make the cross-ratio:

$$m^2(Y_{H2}) = (0 Y_{H2}^2 Y_{H2}(P_{2M}) \infty) = \frac{1.073}{3.597} = 0.298,$$

$$m^2(U_2) = (U_2(0) U_2^2 U_2(P_{2M}) U_2(\infty)) =$$

$$= (3.89 \quad 3 \quad 1.95 \quad 0) = 0.296 \div 1,$$

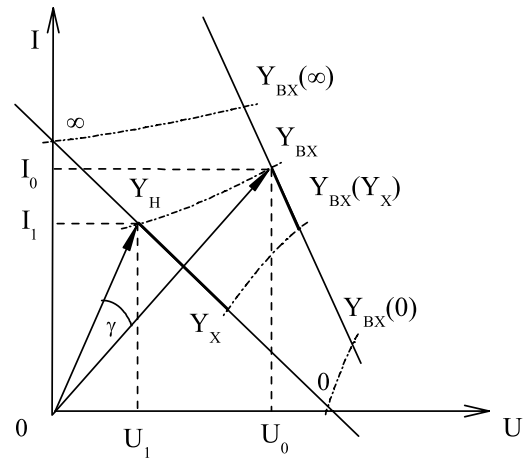

Fig. 3. A rotation of the radius-vector of constant length at the angle γ

$$m^2(Y_{H1}) = (Y_{H1}(0) Y_{H1}^2 Y_{H1}(P_{2M}) Y_{H1}(\infty)) =$$

$$= (1.8 \quad 2.37 \quad 3.14 \quad 5) = 0.216 \div 0.72 = 0.299,$$

$$m^2(U_1) = (U_1(0) U_1^2 U_1(P_{2M}) U_1(\infty)) =$$

$$= (4.88 \quad 4.56 \quad 4.2 \quad 3.51) = 0.299 \div 1,$$

Let us express the changes of the regime $Y_{H2}^1 \rightarrow Y_{H2}^2$:

$$m^{21}(Y_{H2}) = (0 Y_{H2}^2 Y_{H2}^1 \infty) = \frac{Y_{H2}^2}{Y_{H2}^1} = \frac{1.073}{10.414} = 0.103 = \frac{1}{m^{12}(Y_{H2})} = \frac{1}{9.7},$$

$$m^{21}(U_2) = (U_2(0) U_2^2 U_2^1 U_2(\infty)) =$$

$$= (3.89 \quad 3 \quad 1 \quad 0) = 0.297 \div 2.89 = 0.103,$$

$$m^{21}(Y_{H1}) = (Y_{H1}(0) Y_{H1}^2 Y_{H1}^1 Y_{H1}(\infty)) =$$

$$= (1.8 \quad 2.37 \quad 3.96 \quad 5) = 0.215 \div 2.074 = 0.103,$$

$$m^{21}(U_1) = (U_1(0) U_1^2 U_1^1 U_1(\infty)) =$$

$$= (4.88 \quad 4.56 \quad 3.86 \quad 3.51) = 0.299 \div 2.89 = 0.103$$

It is seen that the group property is carried out:

$$m^{21} = m^2 \div m^1$$

This follows from the structure of the cross-ratio m^1, m^2 . The second fractions for the scale value $U_1(P_{2M})$ are reduced, i.e. such a definition of the regime change is matched with the definition of regime itself.

IV. VARIANTS OF THE EXPRESSIONS OF THE CROSS-RATIO

There are different variants of the expressions of the cross-ratio depending on the choice of the extreme points and the scale point. Let us consider the first $TP1$. Expression (4)

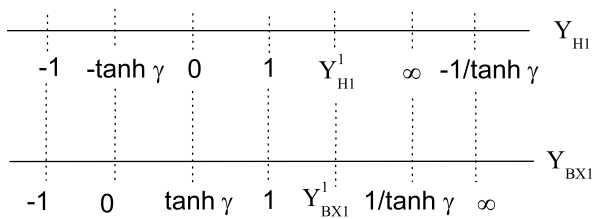

Fig. 4. A conformity or mapping of the points of line Y_{H1} on the points of line Y_{BX1} , including the negative values

on Fig. 4 also sets conformity or mapping of the points of line Y_{H1} on the points of line Y_{BX1} , including the negative values. We assume that the normalized values $Y_{H1}/Y_{H1.C}$, $Y_{BX1}/Y_{BX1.C}$ are just equal to Y_{H1} and Y_{BX1} . The representative load value of two-port, which transmits energy, is a characteristic value. In this case $Y_{BX1} = Y_{H1} = \pm 1$. We make the cross-ratio $m^1(Y_{H1})$, using the extreme values $Y_{H1}(0) = 0$, $Y_{H1}(\infty) = \infty$ and characteristic value $Y_{H1}(1)$ as a scale point:

$$m^1(Y_{H1}) = (0 Y_{H1}^1 1 \infty) = Y_{H1}^1$$

Then the cross-ratio takes the form:

$$m^1(Y_{BX1}) = (\tanh \gamma Y_{BX1}^1 1 \frac{1}{\tanh \gamma}) = \frac{Y_{BX1}^1 - \tanh \gamma}{1 - Y_{BX1}^1 \cdot \tanh \gamma}$$

We express the regime changes when $Y_{H1}^1 \rightarrow Y_{H1}^2$ and respectively $Y_{BX1}^1 \rightarrow Y_{BX1}^2$:

$$m^{21} = m^2 \div m^1 = \frac{Y_{BX1}^2 - \tanh \gamma}{1 - Y_{BX1}^2 \cdot \tanh \gamma} \div \frac{Y_{BX1}^1 - \tanh \gamma}{1 - Y_{BX1}^1 \cdot \tanh \gamma} = Y_{H1}^2 \div Y_{H1}^1$$

It is seen that the group property is also carried out. It may be noted that the expressions for the regime changes and the expressions for the conductivity changes at the input and output are analytically expressed in different ways, but their numerical values are equal. In this connection, we can choose extreme points and a scale point in such a way so that the expressions for these changes are the same. To do this we use

the characteristic values $-1, 1$ as the extreme values. Then:

$$m^{21}(Y_{H1}) = (-1 Y_{H1}^2 Y_{H1}^1 1) =$$

$$\frac{Y_{H1}^2 + 1}{Y_{H1}^2 - 1} \div \frac{Y_{H1}^1 + 1}{Y_{H1}^1 - 1} = \frac{1 + (Y_{H1}^2 - Y_{H1}^1)/(1 - Y_{H1}^2 \cdot Y_{H1}^1)}{1 - (Y_{H1}^2 - Y_{H1}^1)/(1 - Y_{H1}^2 \cdot Y_{H1}^1)}$$

The resulting expression shows that **there is solid argumentation to enter the value of load change in the form:**

$$Y_{H1}^{21} = (Y_{H1}^2 - Y_{H1}^1)/(1 - Y_{H1}^2 \cdot Y_{H1}^1)$$

Then, regime change is:

$$m^{21}(Y_{H1}) = \frac{1 + Y_{H1}^{21}}{1 - Y_{H1}^{21}}$$

Similarly, the same regime change and the conductivity change are resulted at the input:

$$m^{21}(Y_{BX1}) = (-1 Y_{BX1}^2 Y_{BX1}^1 1) = \frac{1 + Y_{BX1}^{21}}{1 - Y_{BX1}^{21}}$$

where:

$$Y_{BX1}^{21} = (Y_{BX1}^2 - Y_{BX1}^1) \div (1 - Y_{BX1}^2 \cdot Y_{BX1}^1)$$

We are using as a scale or a unit point $Y_{H1}(1) = 0$ for the setting of the regime. This point corresponds to the point $Y_{BX1}(1) = \tanh \gamma$ on Fig. 4. Then:

$$m^1(Y_{H1}) = (-1 Y_{H1}^1 0 1) = \frac{1 + Y_{H1}^1}{1 - Y_{H1}^1}$$

Because the same extreme points are used in the cross-ratio

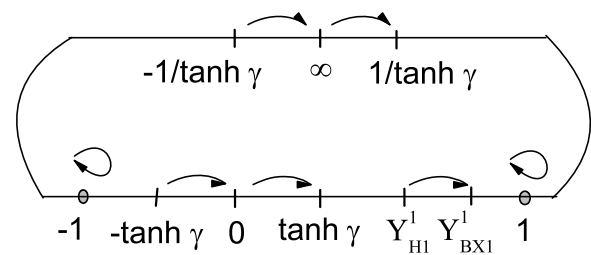

Fig. 5. A movement of the point from position Y_{H1} to position Y_{BX1} for different initial values Y_{H1}

for the input and output, we can consider the point Y_{H1} and Y_{BX1} on the superposed axis on Fig. 5. This figure represents a movement of the point from position Y_{H1} to position Y_{BX1} (or motion of segment $Y_{H1}Y_{BX1}$) for different initial values Y_{H1} , as shown by arrows. Then, the points ± 1 are fixed. You can make a cross-ratio to the points Y_{H1}, Y_{BX1} relatively fixed points, which determines the "length" of segment $Y_{H1}Y_{BX1}$:

$$m(Y_{H1} Y_{BX1}) = (-1 Y_{H1} Y_{BX1} 1)$$

It is known the properties of such cross-ratio in projective geometry, its value does not depend on values Y_{H1}, Y_{BX1} . Therefore, we set $Y_{H1} = 0$ and $Y_{BX1} = \tanh \gamma$ for simplifying of the record:

$$m(Y_{H1} Y_{BX1}) = \frac{1 - \tanh \gamma}{1 + \tanh \gamma} = K_{PM}$$

It is seen that the "length" of segment $Y_{H1} Y_{BX1}$ equals to the maximum of the efficiency K_{PM} of a two-pole. Therefore, it turns out that the concept of maximum efficiency is already into this geometric interpretation, and do not have to "think of" his definition.

Thus, the proposed geometric approach provides variants for the justified definition of a regime and his changes for the different parts of a circuit.

V. APPLICATION OF THE INVARIANT PROPERTIES OF CIRCUITS

The invariance of a cross-ratio can be applied in practice of measurements, because many measuring means exercise linear-fractional transformation on the input value [6].

The cross-ratio allows obtaining also the convenient calculated expression $Y_{BX}(Y_H)$ of the type (3), but without the explicit finding of a -parameters. It is known, for the finding of the a -parameters necessary to exercise three experiments measuring values Y_{BX}, Y_H .

The most simple expressions for the calculation of the a -parameters are obtained from experiments, in which the regime of SC and OC at the output (two experiences) and one of such experiments at the input when the circuit is supplied from the output. Clearly, such manipulations are not always convenient to implement (the length of the network, the technical complexity of switching power supply from the input to the output). It is therefore, possible the following algorithm of the calculation:

-Circuit is tested (three experience are exercised) for the three arbitrary values of the loads: $Y_H(0), Y_H(\infty)$ are the extreme values and $Y_H(1)$ is the scale value. If possible, it is believed $Y_H(0) = 0, Y_H(\infty) = \infty$, as a regime of the SC and OC . Then, the scale value $Y_H(1)$ is convenient to choose so that the voltage $U_H(1) = U_H(0)/2$.

- The respective values $Y_{BX}(0), Y_{BX}(\infty), Y_{BX}(1)$ are measured.

- For the current load value Y_H^1 the cross-ratio m^1 is calculated.

- The current value Y_{BX}^1 is found through the m^1 from a similar, but a reciprocal expression.

Because

$$m^1(Y_{BX}) = \frac{Y_{BX}^1 - Y_{BX}(0)}{Y_{BX}^1 - Y_{BX}(\infty)} \div \frac{Y_{BX}(1) - Y_{BX}(0)}{Y_{BX}(1) - Y_{BX}(\infty)} = \frac{Y_{BX}^1 - Y_{BX}(0)}{Y_{BX}^1 - Y_{BX}(\infty)} \div N_{BX}(1) \quad (13)$$

we get the final calculation expression:

$$Y_{BX}^1 = \frac{Y_{BX}(0) - m^1 N_{BX}(1) Y_{BX}(\infty)}{1 - m^1 N_{BX}(1)} \quad (14)$$

For the following values of the load Y_H^2 value of the m^2 is firstly found and value of the Y_{BX}^2 is further found.

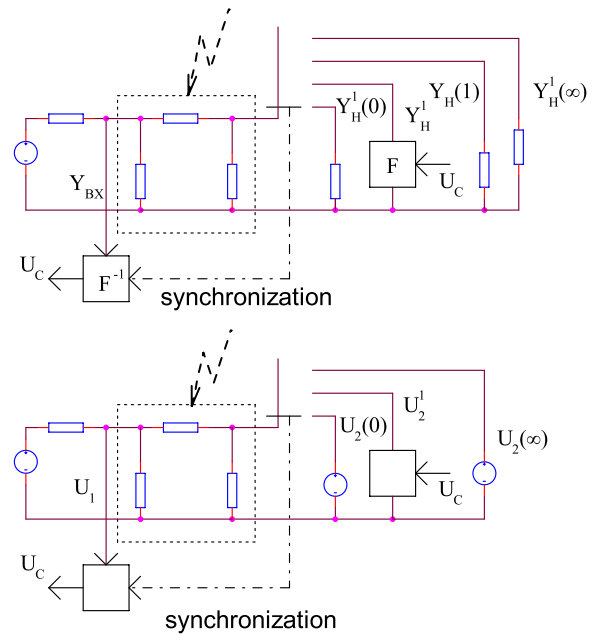

Fig. 6. System of accurately transmission of the measuring signal

Cross-ratio permits accurately to transmit analog (measuring signal) via the unstable two-pole [7]. The scheme of such system is presented on Fig. 6. In a short time when the parameters of a circuit does not significantly are changed, the four samples of load are transmitted by connecting the respective loads $Y_H(0), Y_H^1, Y_H(1), Y_H(\infty)$. Three of them $Y_H(0), Y_H(1), Y_H(\infty)$ are extremely and scale values, and the sample Y_H^1 is a signal or an information sample. Therefore, its value is calculated by the formula which is obtained similar to (14) through the prepared cross-ratio m^1 :

$$Y_H^1 = \frac{Y_H(0) - m^1 N_H(1) Y_H(\infty)}{1 - m^1 N_H(1)} = F(m^1) \quad (15)$$

We accept that value of the $m^1 = U_C$.

At the input of a circuit the cross-ratio or the signal is calculated similar to (13), using the measured values of samples of the input conductivity:

$$m^1 = \frac{Y_{BX}^1 - Y_{BX}(0)}{Y_{BX}^1 - Y_{BX}(\infty)} \div N_{BX}(1) = F^{-1}(Y_{BX}^1) \quad (16)$$

We can also use only three samples where a circuit is loaded on the sources of voltages on Fig. 6.

Because

$$m^1(U_2) = (U_2(0) U_2^1 U_2(P_{2M}) U_2(\infty)) = \frac{U_2^1 - U_2(0)}{U_2^1 - U_2(\infty)}$$

hence it follows the value of a signal sample, similar to (15)

$$U_2^1 = \frac{U_2(0) - m^1 U_2(\infty)}{1 - m^1}$$

At the input of a circuit the cross-ratio or the signal is calculated similar to (16), using the measured values of samples:

$$m^1 = \frac{U_1^1 - U_1(0)}{U_1^1 - U_1(\infty)}$$

The structure of this expression shows that the errors of measurement of samples of voltages mutually are reduced. More than a simple expression for the signal sample is obtained, using the invariant in the form of an affine ratio:

$$m^1(U_2) = (U_2^1 U_2(0) U_2(\infty)) = \frac{U_2(0) - U_2^1}{U_2(0) - U_2(\infty)}$$

Then the value of the signal sampling is:

$$U_2^1 = U_2(0) + n^1(U_2(\infty) - U_2(0))$$

VI. CONCLUSION

1. The invariant relations for all regime parameters in all parts of cascade circuit are shown.
2. The definition of a regime by the cross-ratio removes the indeterminateness in the choice of the possible relative expressions across all parameters and parts of a circuit.
3. The expressions for calculating the cascade circuit without explicitly finding the a -parameters are obtained.
4. The cross-ratio is an effective way to transmit an analog (measurement signal) via the unstable two-port.
5. The results are applicable to AC circuits.

REFERENCES

- [1] A. A. Penin, "Linear- fractional relation in the problems of analysis of resistive circuits with variable parameters", *Electrichestvo*, 11, 1999, pp.32-44, (Russian).
- [2] A. A. Penin, "Determination of Regimes of the Equivalent Generator Based on Projective Geometry. The Generalized Equivalent Generator", *International Journal of Electrical Systems Science and Engineering*, vol.1, n.3, 2008, pp.169-177.
- [3] C. A. Desoer and E. S. Kuh, *Basic Circuit Theory*, McGraw - Hill, New York, 1969.
- [4] O. Veblen and J. W. A. Young, *Projective Geometry*, vol.1, Blaisdell, New York, 1938- 1946.
- [5] C. K. Kittel, W. D. Knight and M. A. Ruderman, *Mechanics: Berkely Physics Course*, vol.1, McGraw - Hill, New York, 1973.
- [6] A. I. Gerasimov and V. D. Masin, "Application of the properties of linear- fractional transformatoins in the measuring converters", *Pribory, sistemy upravlenia*, n. 9, 1983, pp. 22- 23, (Russian).
- [7] A. A. Penin , "Projective- affine properties of the resistive two-port with the changeable load", *Electrodinamika*, n. 2, 1991, pp.38-42, (Russian).

Alexandr A. Penin graduated from Radio Department Polytechnic Institute in 1974 of Odessa city, Ukraine. The area of research relates to the theory of electrical circuits with variable elements or regimes. The area of interest in engineering practice is the power electronics.