

Verification of a Locked CFD Approach to Cool Down Modeling

P. Bárta

Abstract—Increasing demand on the performance of Subsea Production Systems (SPS) suggests a need for more detailed investigation of fluid behavior taking place in subsea equipment. Complete CFD cool down analyses of subsea equipment are very time demanding. The objective of this paper is to investigate a Locked CFD approach, which enables significant reduction of the computational time and at the same time maintains sufficient accuracy during thermal cool down simulations. The result comparison of a dead leg simulation using the Full CFD and the three LCFD-methods confirms the validity of the locked flow field assumption for the selected case. For the tested case the LCFD simulation speed up by factor of 200 results in the absolute thermal error of 0.5 °C (3% relative error), speed up by factor of 10 keeps the LCFD results within 0.1 °C (0.5 % relative error) comparing to the Full CFD.

Keywords—CFD, Locked Flow Field, Speed up of CFD simulation time, Subsea

I. INTRODUCTION

THE cool down performance of Subsea Production Systems has been predicted by a thermal finite element analysis (FEA) in conjunction with an artificial thermal conductivity approach in the recent years. This approach was proven by several tests to be conservative for the flowing region and was widely accepted by customers during project execution. The FEA approach is very time efficient and allows simulating cool down of the equipment within hours.

One limitation to this approach is modeling of cool down in regions which are outside the main flow during production, where convection effects play an important role – i.e. in dead legs, stagnant regions separated by a closed valve and in fluids within enclosed cavities (actuators, valve cavities). CFD is a more physically sound approach to emulate convective heat transfer compared to FEA [1], [2], [3]. Thus, it is expected that CFD will yield more correct results compared to FEA, in terms of mimicking the actual thermal behavior of a subsea component.

Increasing requirements to the subsea equipment with respect to flexibility, monitoring and longer cool down times raise the need for more accurate analysis of thermal effects. The answer to this need is CFD [4], which allows modeling of the convective heat transfer in the fluid domains [5] and thus replacing the artificial thermal conductivity approach.

P. Bárta works as a Flow Assurance Specialist Engineer at FMC Technologies AS, POB 440, NO-1373 ASKER., Norway (phone: +47 6675 3243; e-mail: pavel.barta@fmcti.com).

Applying CFD allows for designing the subsea equipment simulation model at a lower level of conservatism. Correctly analyzing the equipment's maximum potential minimizes the price of the equipment, which is an important focus both for customers and for FMC.

Complete CFD cool down analyses of subsea equipment is very time demanding. Computational time in the order of 200k CPU-hours is not uncommon, thus there is a need for investigations of measures which may reduce the computational cost of CFD-analyses.

The objective of this paper is to investigate such a CFD analysis methodology that will significantly reduce the computational time, but will maintain sufficient accuracy during thermal cool down simulations.

The paper contains the definition of the Locked CFD approach in Section II, test case description in Section III, the overview of the CFD and LCFD results is given in Section IV, and the comparison and evaluation of the results is presented in Section V. The overall conclusions are stated in Section VI.

II. CFD METHOD DESCRIPTION

A. Approach

The fluid flow pattern in subsea equipment during a cool down is induced by buoyancy. The intensity of the convective heat transfer and the subsequent fluid motion is thus given by temperature difference within the fluid domain, typically between the wall temperatures at a cold and a warm spot. Since the cool down of subsea equipment is a relatively slow process there is no need to update the flow field as frequently as the full CFD solver requires (typically every second) – i.e. the flow field can be locked for the most of the cool down simulation.

TABLE I
TERMINOLOGY OVERVIEW

Term	Description
Locked CFD (LCFD)	CFD simulation assuming constant (locked) velocity field throughout the entire simulation or its part.
Full CFD	The flow field velocities as well as the heat equations are solved for each time step of the CFD simulation.
Locked Flow Field CFD (LFF CFD)	Only the heat equations are solved for each time step of the CFD simulation (flow field is assumed to be constant).

This assumption speeds up the cool down simulation remarkably. While the fluid velocity is locked, only the heat transfer equation (both within fluids and solids) is solved,

which reduces the computational time and allows for coarser time steps. The terminology overview regarding the Locked CFD approach is stated in Table I and Table II.

TABLE II
 LOCKED CFD CONCEPT OVERVIEW

Term	Description
Fully LCFD	LCFD simulation assuming constant velocity field throughout the entire simulation. (LCFD purely consists of LFF CFD.)
Initialized LCFD	LCFD simulation is divided into two parts throughout the simulation. First part is run as Full CFD and the rest as LFF CFD.
Sequential LCFD	LCFD simulation consists of repeated sequences of Full CFD and LFF CFD.

B. Methodology

A CFD simulation partially or fully assuming locked velocities is denoted as Locked CFD (LCFD) simulation. Such LCFD may consist of two types of CFD simulation succeeding each other:

- Full CFD – the Navier-Stokes, continuity, and energy equations are solved for each time step
- LFF CFD – Locked Flow Field CFD: only the heat equations are solved for each time step, the flow field is assumed to be constant

This paper investigates the impact of the sequence and duration of the locked flow field assumption (LFF CFD) on the LCFD analysis results in terms of precision and solution time by testing several combinations of the full and LFF CFD.

C. Tested Sequences of LCFD

Based on the sequence of the full and locked flow field CFD, the following types of LCFD are investigated (Fig. 1):

- Fully LCFD: the flow field is locked during the entire cool down simulation – LCFD (0 - Cool Down Time (CDT)) s
- Initialized LCFD: Full CFD is run in the beginning of the cool down period, locked flow field is assumed during the rest of cool down simulation - full CFD (0 - x) s, LCFD (x - CDT) s
- Sequential LCFD: Sequence of full CFD and LCFD is run throughout the cool down simulation - full CFD (0 - ...) s, LCFD, full CFD, LCFD,, full CFD (... - CDT) s

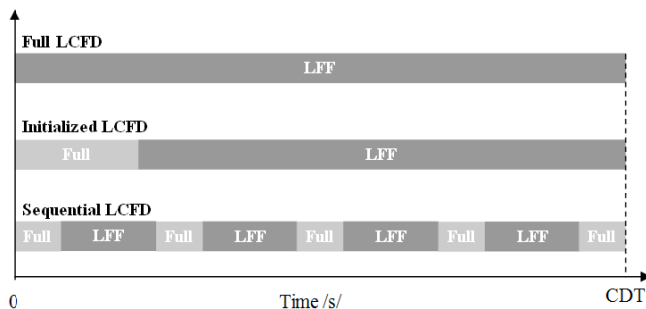

Fig. 1 Investigated types of LCFD

D. Limitations of Locked CFD Approach

It is important to note that LCFD approach has its limitations and shall be used when the following conditions are fulfilled:

- only single phase fluid regions are modeled
- the flow pattern induced by convection in the subsea equipment is relatively constant, thus the pattern needs to be updated only a few times during the cool down period. E.g. LCFD during cool down simulation cannot directly start from production, when gas flows through a header – full CFD has to be run to reach a relatively stable cool down flow field pattern before LCFD is started

III. TEST CASE

The LCFD approach simplifies modeling of convective heat transfer during cool down. Thus the thermal behavior of the validation model must be strongly driven by convective heat transfer.

A manifold dead leg represents a typical case where convective heat transfer plays an important role both during production and cool down. A dead leg is a part of a production system, i.e. pipe (Fig. 2), containing a stagnant fluid volume (Fig. 3). The manifold model chosen to validate the modeling approach consists of a header, a dead leg and a valve. Flowing production fluid heats up the header so it becomes the warmest part of the system. The accumulated heat in the header is the driving force for the convective heat transfer in the dead leg during the cool down. Heat is transported from the header towards the cold spot by convection, both during production and cool down. The conductive heat transfer is by comparison negligible. The valve acts as a cold spot draining heat from the system.

Since the model is symmetric only half of it is considered. The model consists of a production fluid domain in a steel pipe covered by insulation, see Fig. 4.



Fig. 2 Pipe/Valve domain



Fig. 3 Production fluid domain and valve cavity

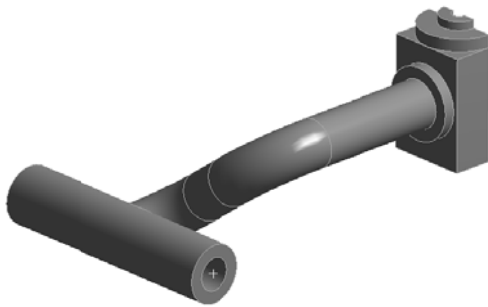

Fig. 4 Insulation domain

All external surfaces are exposed to an ambient sea temperature of 5 °C and a heat transfer coefficient of 1000 W/m²K is applied. The initial header temperature is set to 50 °C.

Adiabatic boundaries are assumed on the remaining outer faces of the model, at the header ends and at the symmetry plane of the valve.

The model has been built in ANSYS and CFD simulation performed by ANSYS CFX. The SST turbulence model has been used to approximate the effect of turbulence in the fluid domain.

The computational mesh (Fig. 5) mainly consists of tetrahedral elements. Prism elements have been used to resolve the production fluid boundary layers to $y^+ = 1$. The total number nodes is 59 428 for solid domains and 261 249 for fluid domain (production fluid).

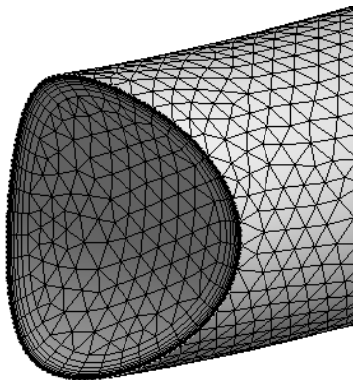

Fig. 5 Computational mesh - CFD

IV. RESULTS

The header temperature and minimum temperatures in the upper bend and at the end of the dead leg were chosen for comparison of the full CFD and LCFD cool down simulations (Fig. 6). The temperatures are denoted in the following text as:

- header temperature - T_h ,
- minimum temperature at upper bend - T_c ,
- minimum temperature at end of dead leg - T_e .

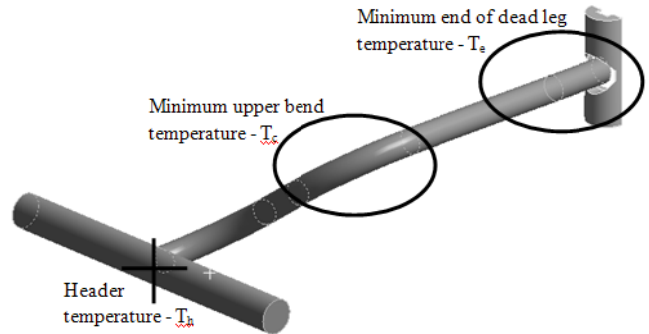

Fig. 6 Temperature monitor points

A. Simulation of the Initial State

A steady state and transient simulation of the initial state of the cool down simulation have been performed to fully develop the temperature and heat flux pattern resulting from the temperature initialization of the header production fluid. This solution was used to initialize all cool down simulations.

The adaptive time step option, based on mean Courant number equal to 20, was used to determine the time step during the transient part of the simulation. The approximate length of the time step during the transient simulation was 0.6 s.

The temperature distribution in the production fluid domain and valve in the dead leg are shown in Fig. 7 and Fig. 8.

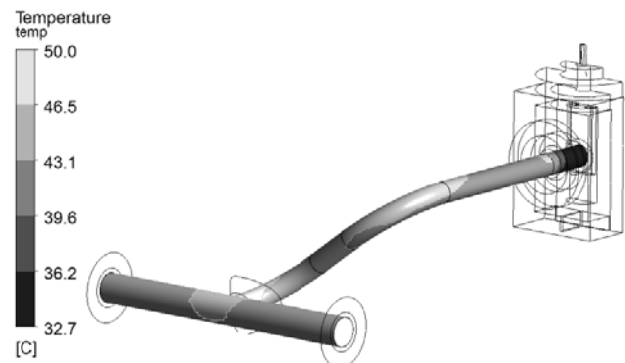

Fig. 7 Beginning of cool down ($t = 0$ s) – temperature in production fluid (PF) domain

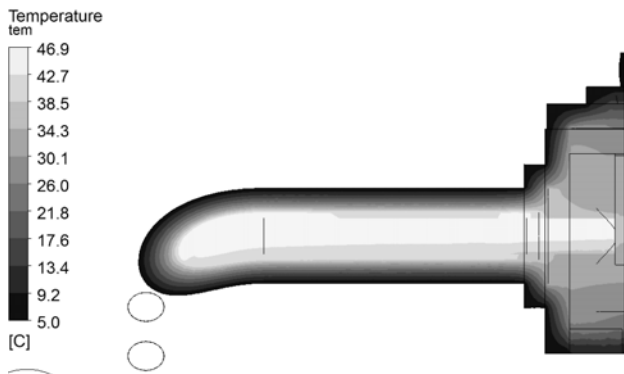

Fig. 8 Beginning of cool down ($t = 0$ s) – temperature in dead leg and valve

B. Full CFD Cool Down Simulation

All production fluid residuals (RMS) have been kept between $1E-04$ and $1E-03$ and imbalances within 1% during the entire cool down simulation. The total length of the simulation was set to 54 000 s (15 hours).

The adaptive time step option, based on mean Courant number equal to 20, was used to determine the time step during the transient part of the simulation. The approximate length of the time step during the transient simulation varied from 0.6 s to 1.5 s.

The temperature distribution in the production fluid domain and valve in the dead leg are shown in Fig. 22b and Fig. 23b. The temperatures monitored during cool down simulation are displayed on Fig. 9 for the selected locations (see Fig. 6).

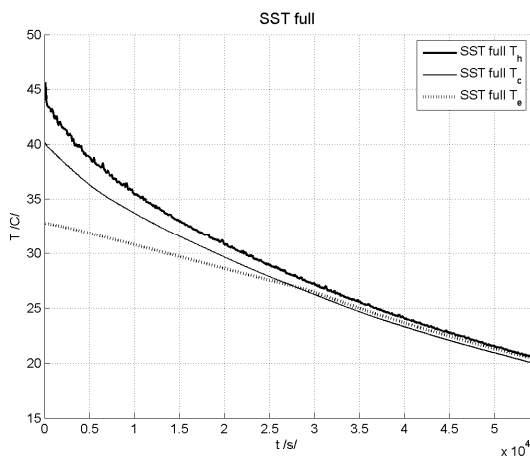

Fig. 9 Temperatures during full CFD cool down simulation

C. Locked CFD Cool Down Simulation

All the simulations are initialized with the transient simulation of the initial state. The overview of the LCFD simulation is given in the following table:

The graphs in Fig. 10 - Fig. 13 display temperatures in selected locations during the cool down LCFD simulations (see Fig. 6). The temperature distribution in the production fluid domain and valve in the dead leg is shown in Fig. 22a and Fig. 23 (a).

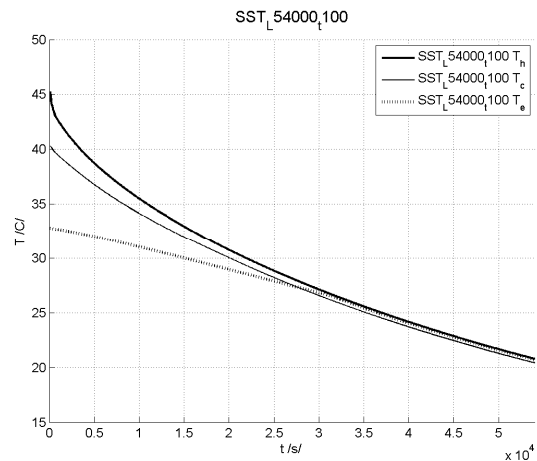

Fig. 10 Temperatures during fully LCFD cool down simulation

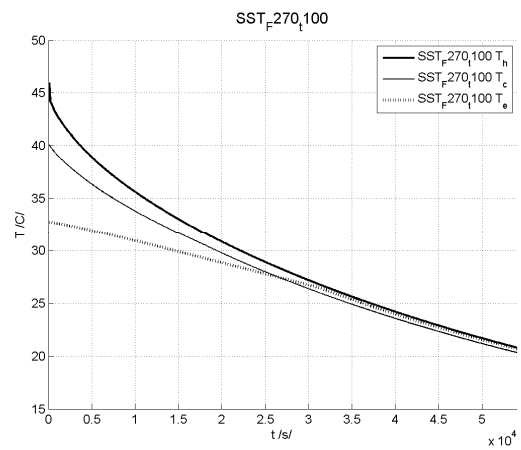

Fig. 11 Temperatures during Initialized LCFD cool down simulation – 270 s full CFD

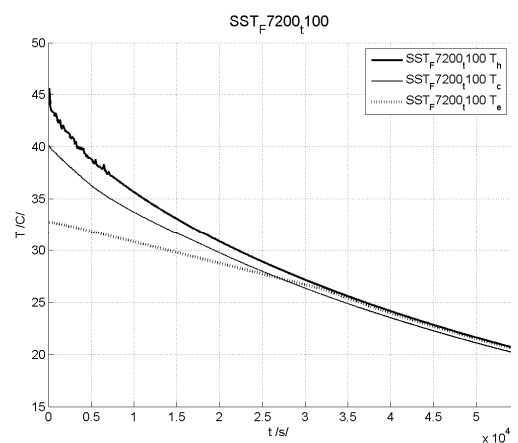

Fig. 12 Temperatures during Initialized LCFD cool down simulation – 7 200 s full CFD

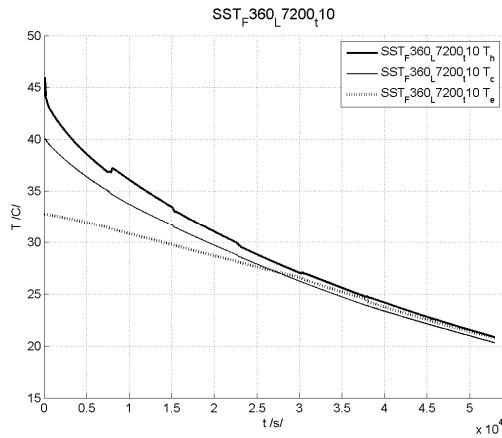

Fig. 13 Temperatures during Sequential LCFD cool down simulation

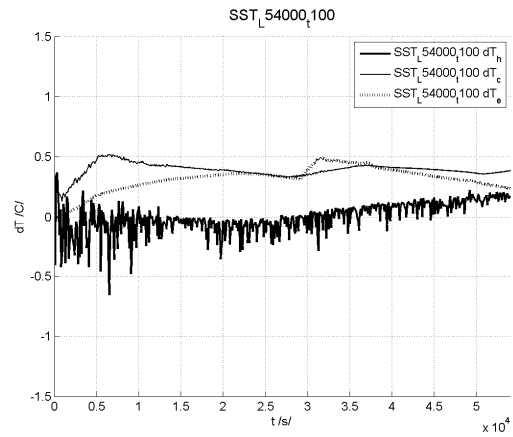

Fig. 14 Absolute error fully LCFD

V. COMPARISON

The temperatures resulting from the locked CFD (T_{LCFD}) are compared to the full CFD (T_{full_CFD}) temperature results by absolute error δT :

$$\delta(T(t)) = T_{fullLCFD}(t) - T_{LCFD}(t) \quad (1)$$

The absolute error does not capture the relativity of the temperature error towards the decreasing temperature potential. Thus the absolute error naturally minimizes towards the end of the cool down.

A relative error, κ [%], based on ambient temperature $T_{ambient}$ is therefore introduced and is used to evaluate the match between the temperatures resulting from FEA approximations (T_{FEA}) and CFD simulation (T_{CFD}).

$$\kappa(T_{LCFD}(t)) = \frac{T_{fullLCFD}(t) - T_{LCFD}(t)}{T_{LCFD}(t) - T_{ambient}} \cdot 100\% \quad (2)$$

The relative error can be interpreted as a measure of modeling inaccuracy with respect to the actual temperature potential (the actual temperature minus ambient temperature).

A. Fully LCFD

Absolute and relative error between fully locked CFD and full CFD during the cool down simulation for the selected temperatures is displayed on Fig. 14 and Fig. 15. Observations based on these plots are summarized in Table III.

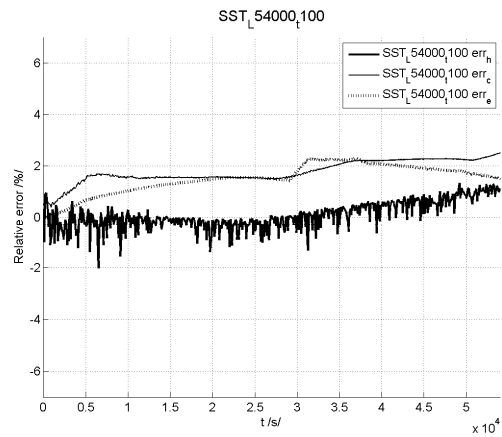

Fig. 15 Relative error fully LCFD

B. Initialized LCFD

Absolute/relative error between Initialized LCFDs and full CFD during CD simulation for selected temperatures are shown on Fig. 16 - Fig. 19. The observations from these four graphs are summarized in Table IV.

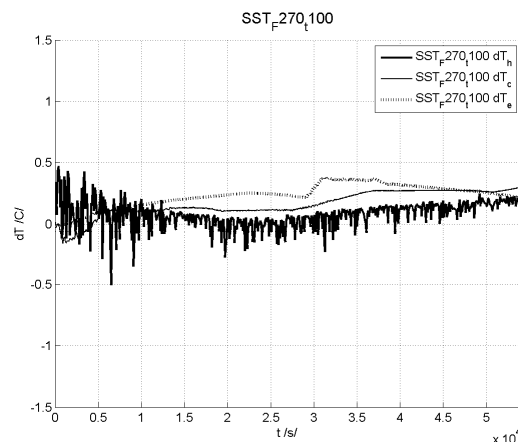

Fig. 16 Absolute error Initialized LCFD – full CFD 270 s

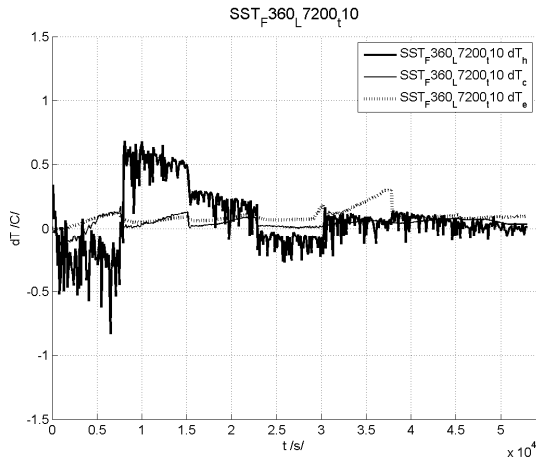

Fig. 17 Absolute error Initialized LCFD – full CFD 7200 s

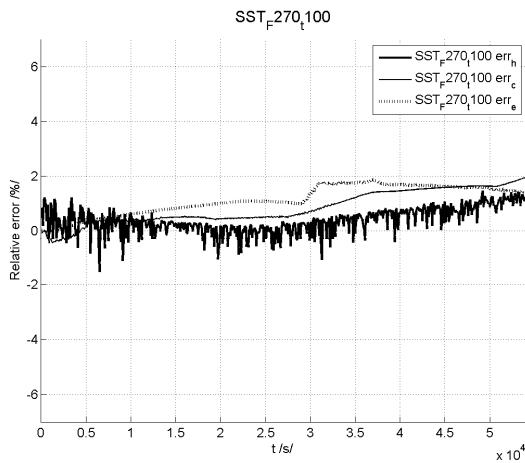

Fig. 18 Relative error Initialized LCFD – full CFD 270 s

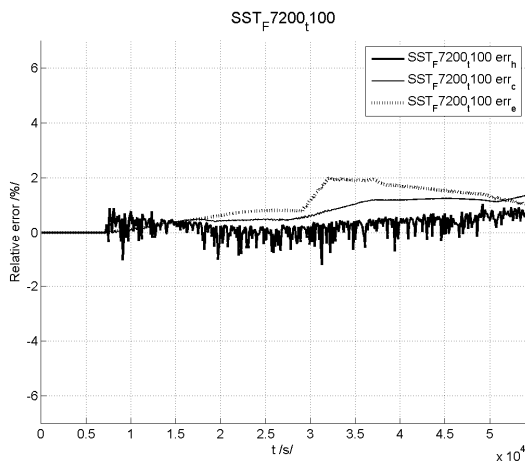

Fig. 19 Relative error Initialized LCFD – full CFD 7 200 s

C. Sequential LCFD

The last method tested is the Sequential LCFD. Fig. 20 and Fig. 21 show the absolute and relative error between Sequential LCFD and full CFD during CD simulation for selected temperatures. The observations from the two graphs are summarized in Table V.

Temperature distribution in the production fluid domain, valve in the dead leg is shown in Fig. 22 and Fig. 23.

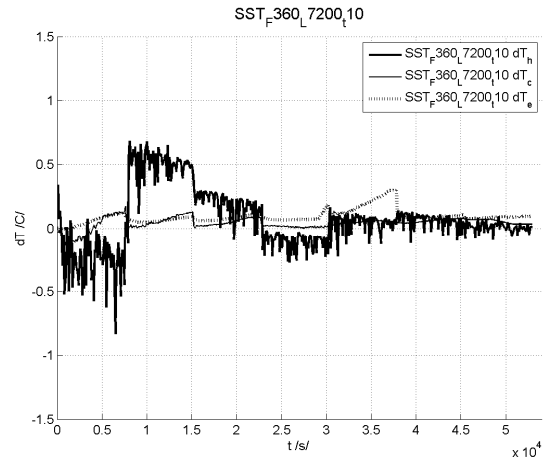

Fig. 20 Absolute error Sequential LCFD

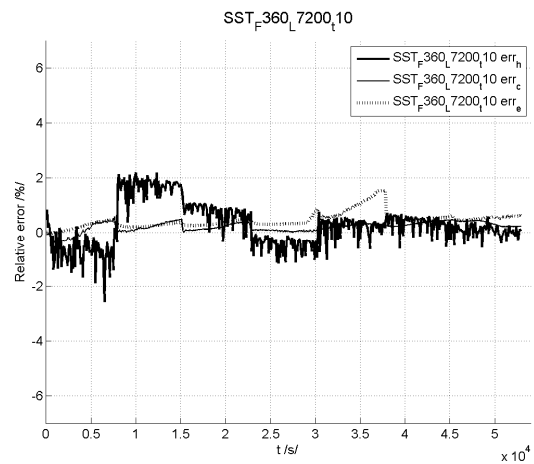

Fig. 21 Relative error Sequential LCFD

TABLE III
 FULLY LCFD – RESULT OVERVIEW

Error	Trend		Magnitude		Reference
	during CD	end of CD	during CD	end of CD	
Absolute	Constant	Varying	± 0.5 °C	+ 0.5 °C	Fig.
Relative	Constant	Varying	± 2 %	(1 - 3) %	Fig.

TABLE IV
 INITIALIZED LCFD – RESULT OVERVIEW

LCFD	Error	Trend		Magnitude		Reference
		during CD	end of CD	during CD	end of CD	
Full CFD 270 s	Absolute	Constant	Increase	± 0.4 °C	~ 0.25 °C	Fig. 16
	Relative	Constant	Varying	(-1; +2) %	(1 - 2) %	Fig. 18
Full CFD 7 200 s	Absolute	Constant	Constant	(- 0.25; +0.4) °C	+ 0.2 °C	Fig. 17
	Relative	Constant	Varying	(-1; +2) %	~ 1 %	Fig. 19

TABLE V
 SEQUENTIAL LCFD – RESULT OVERVIEW

Error	Trend		Magnitude		Reference
	during CD	end of CD	during CD	end of CD	
Absolute	Decrease	Constant	± 0.6 °C	~ 0.1 °C	Fig. 20
Relative	Decrease	Constant	± 2 %	~ 0.5 %	Fig. 21

D. Comparison for LCDF Simulations

The comparison between the absolute and relative LCFD errors (Table VI and Table VII) leads to the following observations:

- The error during the CD simulation is similar for all LCFDs,
- The sequential method displays the smallest error at the end of cool down simulation,
- The sequential method shows higher accuracy towards the end of cool down simulation comparing to the other tested LCFD methods.

Several observations have been made based on the simulation time comparison (Table VIII):

- The total length of the full CFD positively affects the agreement between full CFD and LCFD, when looking at the fully locked CFD and Initialized LCFD,
- The fully locked approach can provide results as quickly as an FEA model: it is 200 times faster comparing to full CFD,
- As stated above, extension of the initialized period of the CFD contributes to the agreement between full CFD and LCFD, but the simulation time grows rapidly. Thus regarding the precision and solution time it is more efficient to use short full CFD sequences distributed along the cool down simulation (Sequential LCFD),
- The sequential approach reduced the full CFD solution by a factor of 10 (current setup).

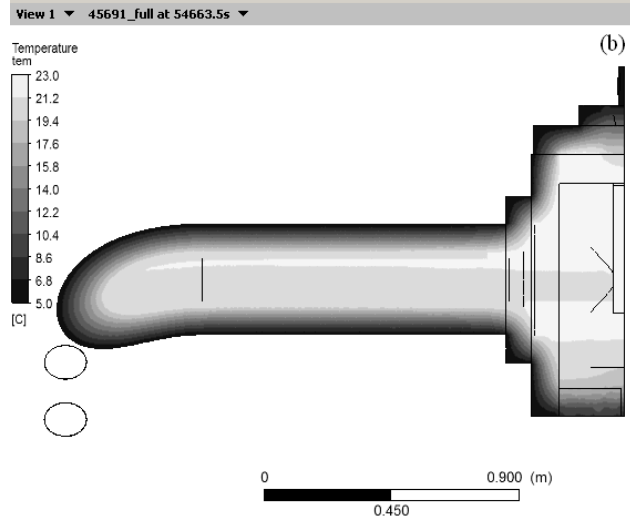
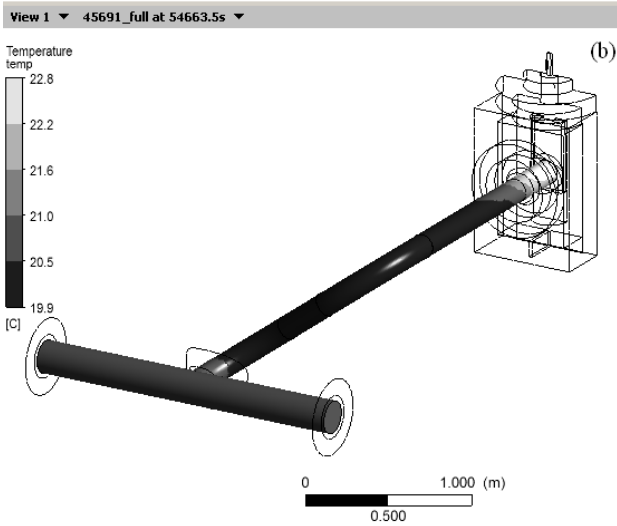
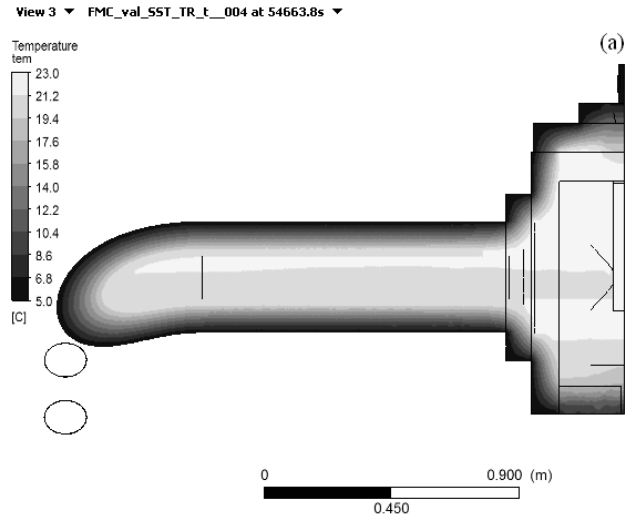
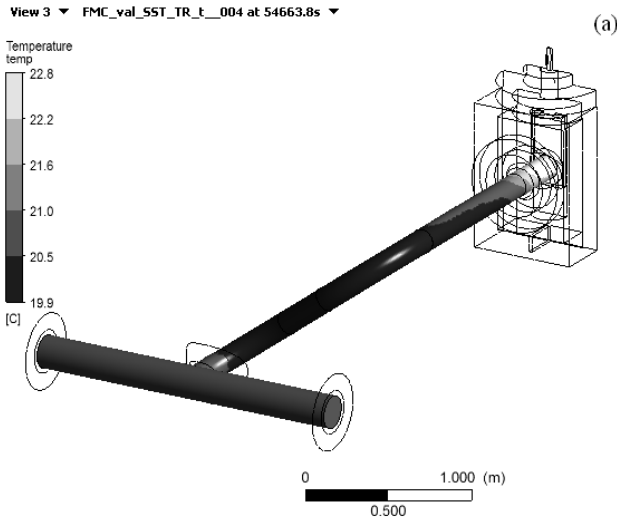

Fig. 22 End of cool down (t = 54 663 s) – PF temperature (a) Sequential LCFD (b) full CFD

Fig. 23 End of cool down (t = 54 663 s) – temperature field in header and dead leg (a) Sequential LCFD (b) full CFD

TABLE VI
 ABSOLUTE ERROR – LCFD OVERVIEW

LCFD	Trend		Magnitude	
	during CD	end of CD	during CD	end of CD
Fully locked	Constant	Varying	± 0.5 °C	+ 0.5 °C
Initialized - Full CFD 270 s	Constant	Increase	± 0.4 °C	~ 0.25 °C
Initialized - Full CFD 7 200 s	Constant	Constant	(- 0.25; +0.4) °C	+ 0.2 °C
Sequential	Decrease	Constant	± 0.6 °C	~ 0.1 °C

TABLE VII
RELATIVE ERROR – LCFD OVERVIEW

LCFD	Trend		Magnitude	
	during CD	end of CD	during CD	end of CD
Fully locked	Constant	Varying	± 2 %	(1 - 3) %
Initialized - Full CFD 270 s	Constant	Varying	(-1; +2) %	(1 - 2) %
Initialized - Full CFD 7 200 s	Constant	Varying	(-1; +2) %	~ 1 %
Sequential	Decrease	Constant	± 2 %	~ 0.5 %

TABLE VIII
SIMULATION TIME COMPARISON

CFD	Solution time [h] **			Speedup factor (Full CFD/LCFD)
	LCFD run	full CFD	Total	
Full CFD	-	300	300	1x
Fully locked	1.5	-	1.5	200 x
Initialized - full CFD 270 s	1.5	1.5	3	100 x
Initialized - full CFD 7 200 s	1.3	40	41.3	7.3 x
Sequential	14*	16	30	10 x

* time step 10 s (other methods - 100 s)

** distributed solution on 16 cores

VI. CONCLUSIONS AND RECOMMENDATIONS

Three LCFD methods (Fully locked CFD, Initialized LCFD and Sequential LCFD) have been compared to a full CFD simulation on a model of a header dead leg. Agreement between three local temperatures (header temperature, upper bend and end of dead leg minimum temperatures) during cool down was evaluated to validate the LCFD approach.

The LCFD approach can approximate full CFD simulation with relative error around 2 % during the cool down simulation. In the case of Sequential LCFD the relative error towards the end of cool down simulation is around 0.5 % (absolute error 0.1 °C).

The LCFD simulation significantly speeds up the full CFD simulation:

- 200 times in case of Fully locked CFD,
- 10 times in case of Sequential LCFD.

The shortening of the simulation time in combination with small relative error comparing to the standard CFD approach, makes the LCFD a preferred approach to subsea cool down simulations.

REFERENCES

- [1] R. Moe, S. Sørbye, K. Skogen and C. Lofseik, "A Comparison of Experimental Data and CFD Predicted Cool Down in Subsea Equipment," in Proceedings of the *Fourth International conference on CFD in the Oil and Gas, Metallurgical & Process Industries*, SINTEF/NTNU, Trondheim, Norway, June 2005.
- [2] U. Mme, S. Johansen, S. Sarkar, R. Moe, A. Goldszal, H. Holm and Y. Ladam, "Flow and heat transfer in pipe caused by localized cold spot," in Proceedings of the *Sixth International conference on CFD in the Oil*

and Gas, Metallurgical & Process Industries, SINTEF/NTNU, Trondheim, Norway, June 2008.

- [3] S. Taxy, E. Lebreton, "Use of Computational Fluid Dynamics to Investigate the Impact of Cold Spots on Subsea Insulation Performance," in Proceedings of the *Offshore Technology Conference*, Houston, USA, May 2004.
- [4] B. Andersson, R. Andersson, L. Håkansson, M. Mortensen, R. Sudiyono, B. Wachem, *Computational Fluid Dynamics for Engineers*. New York, USA: Cambridge University Press, 2012.
- [5] F. P. Incropera, D. P. Dewitt, T. L. Bergman, A. S. Lavine, *Fundamentals of Heat and Mass Transfer*. USA: John Wiley & Sons, Inc., 2007.