

Using Radio Frequency Identification Technology in Supply Chain Management

Eleonora Tudora and Adriana Alexandru

Abstract—The radio frequency identification (RFID) is a technology for automatic identification of items, particularly in supply chain, but it is becoming increasingly important for industrial applications. Unlike barcode technology that detects the optical signals reflected from barcode labels, RFID uses radio waves to transmit the information from an RFID tag affixed to the physical object. In contrast to today most often use of this technology in warehouse inventory and supply chain, the focus of this paper is an overview of the structure of RFID systems used by RFID technology and it also presents a solution based on the application of RFID for brand authentication, traceability and tracking, by implementing a production management system and extending its use to traders.

Keywords—RFID, RFID Tag, Electronic Product Code (EPC), EPC network, Object Naming Service (ONS), Authentication, Traceability.

I. INTRODUCTION

ALTHOUGH barcodes are the most wide-spread technology for tagging and identification of physical objects used today, this technology suffers from several restrictions and drawbacks. One of the major issues is the need for manual positioning of the item in order to ensure line-of-sight between the reader device and the label [1]. The other problem is that the barcode is not designed to allow distinguishing between individual instances of objects (all objects of the same type have the same ID) and, especially for manufacturing purposes, as the tag is placed on the surface of the physical object to be visible to scanner, it has a low resistance against dirty environments containing for example dust or oil.

The radio frequency identification technology allows remote identification of objects using radio signal, thus without the need for line-of-sight or manual positioning of each item. The RFID tags comprised of a small chip and antenna are attached to the physical objects. When the tag enters the range of the RFID reader, it absorbs the energy from the radio field and the microchip, which bears the unique identity code, returns this

This work was supported by the Ministry of Education, Research and Youth under PNCDI2 programme, contract ATPROD, 12-082/2008.

Eleonora Tudora is with the National Institute for Research and Development in Informatics, 8-10 Averescu Avenue, 011455 Bucharest, Romania (e-mail: gilda@ici.ro).

Adriana Alexandru is with the National Institute for Research and Development in Informatics, 8-10 Averescu Avenue, 011455 Bucharest, Romania (corresponding author to provide phone: +40-744-777-558; fax: +40-21-224-11--21; e-mail: adriana@ici.ro).

information back to the reader via modulation of the radio waves. The transmission distances range of passive tags, which do not have their own power supply, vary from centimeters to meters. Active RFID tags with built-in batteries are able to transmit their data over distances up to 100 m; however, they suffer from larger size and higher price. The major advantage of RFID technology over the barcodes is that the RFID system allows detection of multiple items simultaneously as they pass through a reader field (for example the presence of all the items in a closed box can be checked without opening it). Additionally, each physical object has its unique ID (even two products of the same type have two different IDs) enabling to precisely track and monitor the position of each individually labeled product piece.

II. RFID SYSTEM APPLICATION

The RFID system architecture could always be composed of three basic components: RFID tags, RFID readers and backend systems. Fig. 1 shows the RFID system architecture. Passive RFID tags are powered by the readers and transfer specific information or change status in response. The operations between RFID tags and readers are quite simple while the most complex procedures are implemented in the backend system. Many researches about RFID are devoted to the development of backend system such as software architecture, middleware and platform integration [2], [3].

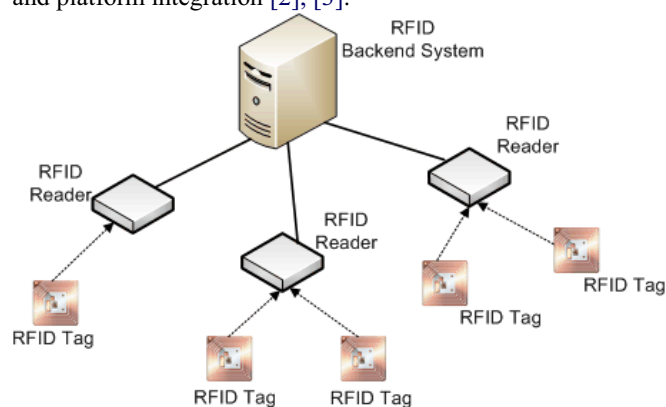

Fig. 1 RFID system architecture

The RFID tags and readers themselves are only a part of the overall RFID solution. Recently, the EPCGlobal Architecture Framework [4] has been developed as a global standard for automatic and unique identification of objects in the physical world and their linkage to the virtual representation in networked databases [5]. EPCGlobal Architecture Framework

provides a collection of hardware, software and data standards aimed at facilitating the exchange of information about physical objects between trading partners.

A crucial component is the introduction of the Electronic Product Code, which is basically unique code number embedded into RFID tag's memory. The EPC coding scheme (with different lengths, like 96, 128 or 256 bits) is designed to contain the information about the manufacturer of the product, type of the product and, as a major advantage over bar codes, a unique serial number of the particular product piece. For instance, 96-bits EPC allows distinguishing of 268 million of different manufacturers, 16 million of different product types for a single manufacturer and 68 billion of different serial numbers of products of the same type.

The EPC Information Service is a network infrastructure that enables trading partners to share different subsets of their

live EPC data through standard interface, thus without any need to access the underlying databases directly. The supporting technology is the Object Name Service used to translate an EPC into one or more Internet addresses (URLs), where further information about the object can be found. Typically, these URLs identify an EPC Information Service, although ONS may also be used to associate EPCs with manufacturer's web sites relevant to the objects.

Fig. 2 shows the EPC Network architecture, which is based on that of the standard RFID system. An RFID system consists of three significant elements, the tag attached to the item to be identified, the reader extracting the unique identification from the item's tags, and the backend application system, such as an EPC Network, which filters the EPC Code through its middleware, and which manages all necessary information for providing services.

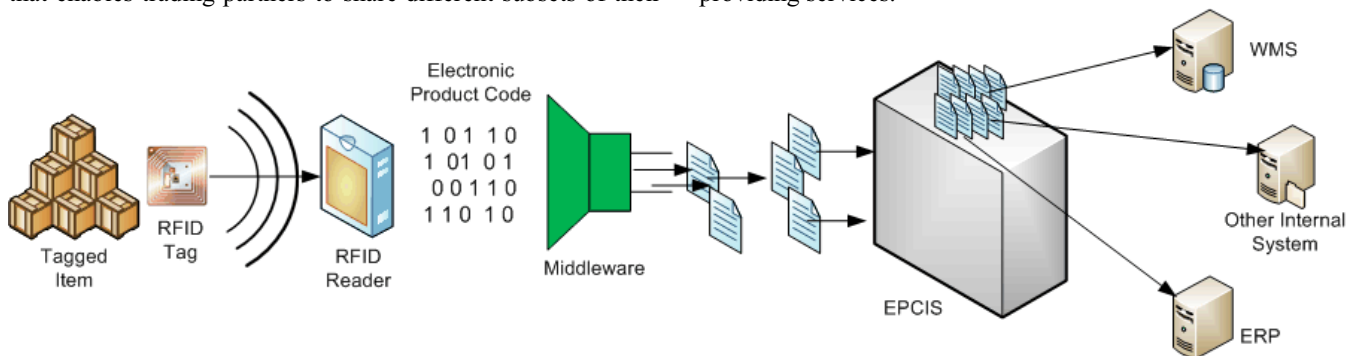

Fig. 2 EPC network architecture

The widespread use of RFID could automate the tracking of pallets, cases, individual products, as well as reusable assets such as bins and containers throughout the supply chain. With RFID, collection of real-time data on individual items could become a reality, which was not possible with the use of bar codes. A future vision of RFID even includes the "Internet of Things", which refers to a global network of computers and objects in which computers are able to identify and store information on any object, anywhere in the world, instantly [6]. RFID is believed to offer many benefits in supply chain management, including shrinkage reduction, material handling efficiency, increased product availability, and improved asset management [7], [8]. Currently, however, the adoption of RFID has been slower than anticipated in supply chain applications

III. POTENTIAL BENEFITS OF RFID TECHNOLOGIES IN SUPPLY CHAINS

RFID technologies offer several contributions to supply chain through their advanced properties such as unique identification of products, easiness of communication and real-time information [9], [10]. The progress through RFID can be observed in different types of supply chains such as warehouse management, transportation management, production scheduling, order management, inventory management and asset management systems [11].

RFID can improve the traceability of products and the visibility throughout the entire supply chain, and also can make reliable and speed up operational processes such as tracking, shipping, checkout and counting processes, which leads to improved inventory flows and more accurate information [12], [13]. Companies integrate and store the more accurate data obtained through RFID technologies in their information technology systems for better supply chain planning and management [14]. There is thus a strong link between IT applications and RFID technologies. Through these numerous benefits, RFID technologies can provide cost reduction, increased revenue, process improvement, service quality, etc. However, the objective of RFID implementation is not just to improve current systems. Reorganizing processes using this new technology can also lead to large gains in the overall supply chain effectiveness [15], [16]. Reengineering models increase possible benefits gained through RFID for all processes of distribution centers and retailers [17]. RFID integration through new business architectures provides more benefits than technology integration in current business processes [18]

IV. USING RFID TECHNOLOGY IN SUPPLY CHAIN

For the purpose of ensuring the authenticity of products and establishing the route followed by a product, one can implement a production management system using RFID

technology and expand its use to trading point. Implemented workflow management systems on manufacturing and transport currently exist, but the chain is not complete, since such systems and a database containing all the information are absent in outlets.

This paper presents a reliable and low cost solution based on the application of RFID technology, both for product brand authentication, as well as for the monitoring of their traceability whilst ensuring information support for distribution control.

Furthermore, in order to eliminate any doubt related to product transport or storage under improper conditions, the project will conduct research to find solutions for monitoring ambient parameters by storing the information obtained throughout the duration of transport or during storage in the memory of an active transponder (coupled with special sensors). Corresponding product traceability information will be read and recorded at each distribution point / center or outlet. Thus, the final consumer will get a product with a transponder / tag attached, in which data on all essential product information and the route it has followed is stored,

including the one related to the final store where the product is located. Customers can check this data using a portable or fixed embedded reader, for example a PDA or mobile phone. If the client wishes, after purchasing the product, he will be registered as the product's owner.

Therefore, a product will be authenticated by three methods accessible to any citizen:

- *product tag* authenticity (hologram, other traditional authentication elements);
- *electronic chip* authenticity of the RFID tag accompanying the product and containing information on traceability and originality of the product;
- *Web site* authenticity based on a unique product ID code for comparing information from the database with that of the electronic chip's official manufacturer.

This will ensure maximum system safety, the sharp decrease of the possibilities of product piracy, increased buyer safety regarding purchased products and a modern and efficient management and tracking system for their products.

The bidirectional information flow of the producers, distributors and retailers' paths is shown in Fig. 3.

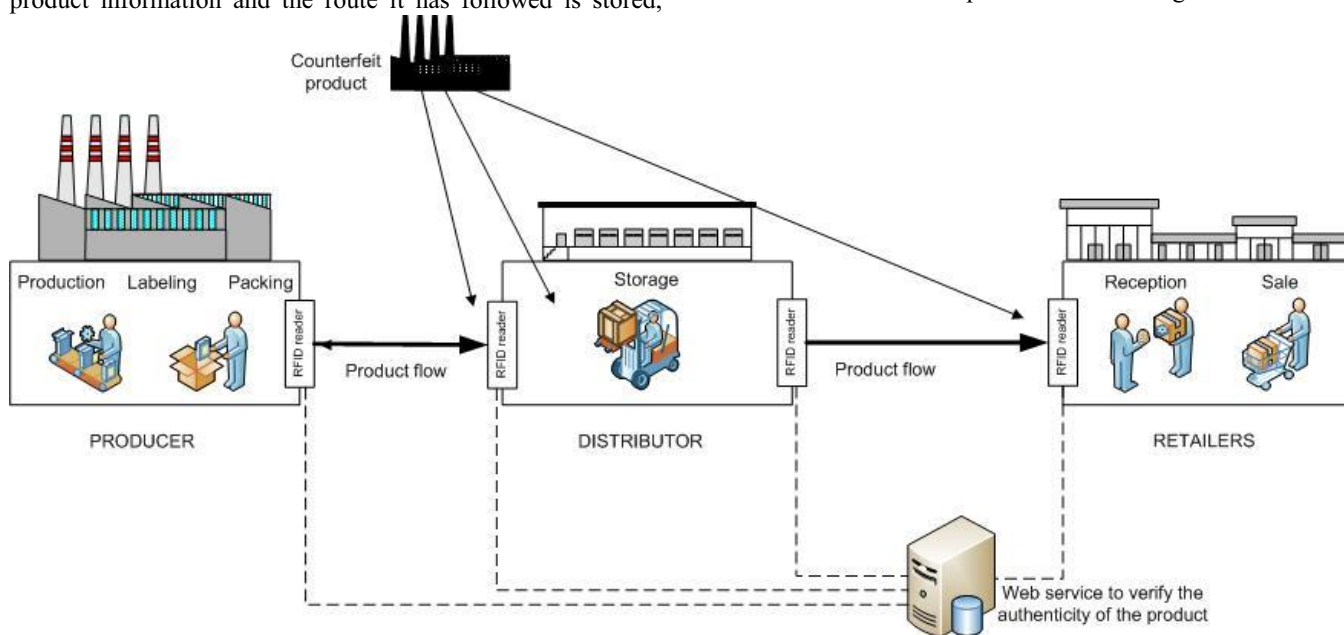

Fig. 3 Simplified representation of the supply chain of branded products

The information flow of the producers includes the following steps taken to ensure traceability:

- Manufacturer product labeling with RFID tag and the inscription of the original information in the RFID transponder's memory. Products are packed in packages labeled with RFID tags and which contain the initial information about the package. The package code is associated with the product codes from the package. The updating of the manufacturer's databases will continue based on the package code until the retail sale of products. The product is stored together with this information into the transponder's memory in the producer's product warehouse and information is

transmitted to the producer's server that contains the end product database.

- When supplying products from the manufacturer's end product warehouse, the date and the warehouse's code will be entered into the memory of the package tag. The information is transmitted to the manufacturer's server via the Internet.
- On entering products into the distributor's warehouse, the information from the package's tag will be read and sent to the producer's server. The tags on the package and products will contain information concerning the reception in the distributor's warehouse. On leaving the distributor's warehouse, the information on the package tag will be read and sent to the manufacturer's server.

The information regarding the release from the distributor's warehouse will be entered into the package's tag and into the products' tags for each product within the package.

- If there are other distributors in the distribution chain, the previous step will be repeated. It is anticipated that there will normally be 3 distributors per supply chain (international, national, regional).
- On entering products into the retailer's warehouse, the information on the package tag will be read and sent to the producer's server. The information concerning the reception in the retailer's warehouse will be entered into the package's tag and into the products' tags for each product within the package. Package labels will be destroyed and the manufacturer's server will be informed.
- In order for the product to be sold, authentication will be performed by using an application that can run either on a PC or a PDA connected to an RFID reader.
- If the product is sold, the retailer has the obligation to register this in the manufacturer's server. This will register the fact that the product with a certain code and traceability information has been sold. An attempt to sell a potential counterfeit product having a cloned tag will be detected when the information concerning the product is checked on the producer's server. A message

stating that the product has already been sold will be returned by the server in this case. Furthermore, the server will inform the producer that there was an attempt to authenticate a counterfeit product.

- An additional RFID tag recording the temperature in a given period of time and with a certain frequency (both programmable through applications running on the manufacturer's and distributor's warehouses) can be attached in certain segments of the supply chain. The temperature recording can also be done when storing products. Information stored in an RFID tag with a sensor will be downloaded using a RFID reader and further sent to the manufacturer's server. When the product's tag will be detached from a monitored product, the manufacturer server will be informed of this. The tag can be reused.
- Electronic tags can optionally be attached to the product after the sale (eventually for service). Tags other than the tags that recorded temperature (and which are attached to packages / products) cannot be reused.

The architecture of the system for the control and checking of products' authenticity is shown in Fig. 4. At the level of storage, the architecture of the system will be organized on several sub-levels.

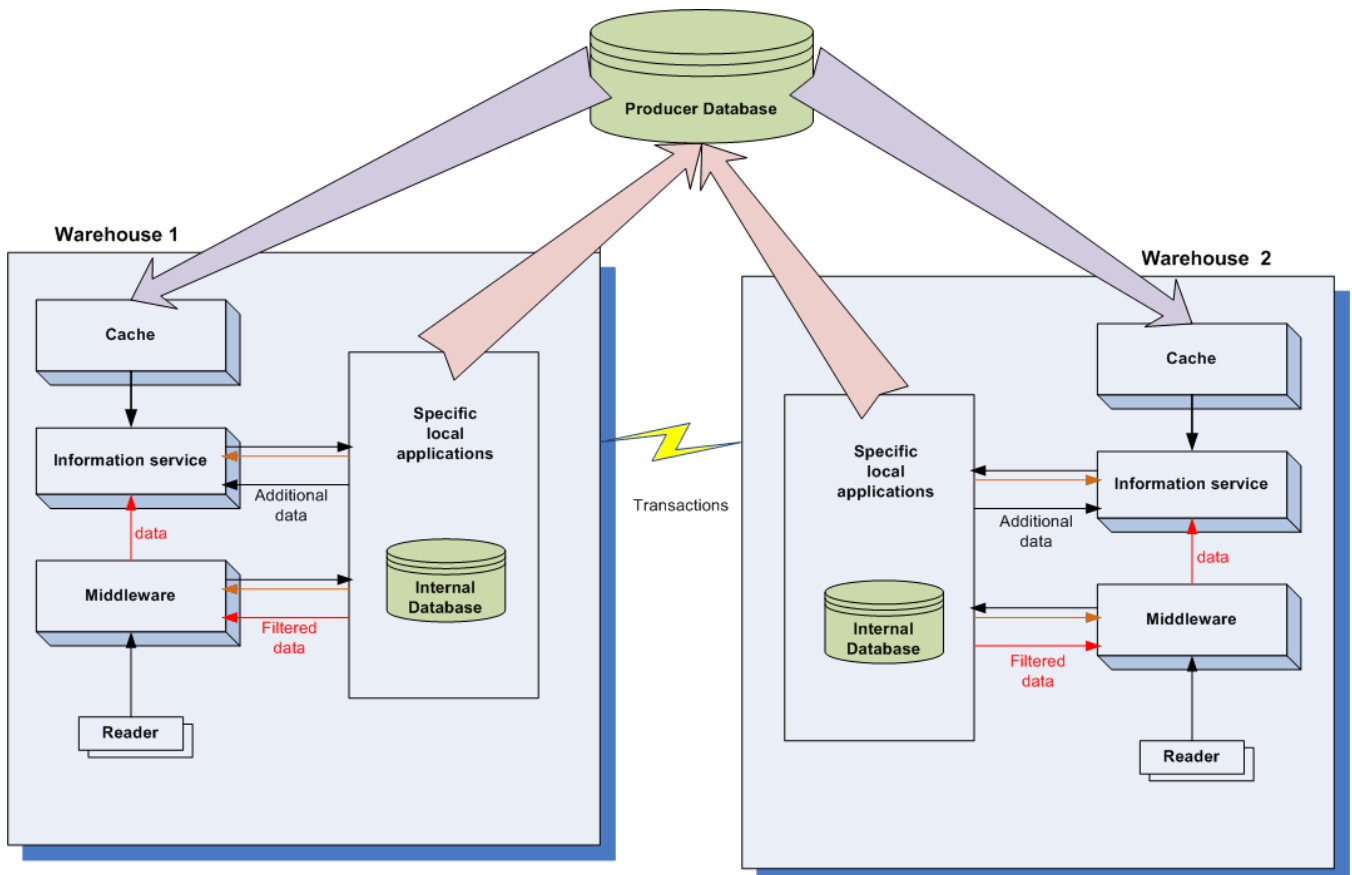

Fig. 4 Architecture of the system

The system includes an RFID middleware with the following characteristics:

- Coordination and integration of readers;
- Monitoring and recording of the tag information;
- Ability to perform simple filtering.

Given the particularities, as well as the complexity of the system and the multiple functions it must perform, the architecture is on several levels thus providing filtering and direction based on a context. Therefore, it provides the scalability of the architecture and an easy integration.

It should be mentioned the fact that the system allows the creation of tags providing facilities to complete the data related to a product's tag, to modify the values, to delete (eliminate) a tag from the data base, to physically remove a tag (with appropriate processing in the database) etc.

The system for the control and checking of products' authenticity consists of several databases, such as: producer database (where all information related to the circulation of a product from producer to consumer is stored), distributor's or trader's storage database, a database installed in the RFID gate controllers.

V. CONCLUSIONS

Among the advantages of using RFID in supply chains can be mentioned.

- RFID provides the automated management of the supply chain, allowing companies to realize significant savings;
- RFID brings an important contribution to the maintenance of record accuracy for product reception and shipment;
- RFID prevents product theft by registering the product at multiple points and creating a record of the route followed by each product;
- RFID has the capability of identifying the product's location, useful especially in case of the product's loss, which allows the manufacturer or distributor to take a form of corrective action.

As a result, RFID technology has a major contribution to the quick location of a product, as well as eliminating opportunities for its falsification.

Supply chain management based on RFID technology faces a number of challenges, especially regarding security operations. It is obvious that the assembly of all of a product's electronic attributes plays a vital role in obtaining benefits for supply chain management systems, but the security of this assembly, the elimination of unauthorized access, the modification and the prevention of illegal product manufacture are still challenges for RFID. Currently, there is a major

interest in the cloning of RFID tags, which would allow the introduction of counterfeit products in supply chains.

REFERENCES

- [1] Pavel Vrba, Filip Macůrek, Vladimír Mařík, Using radio frequency identification in agent-based control systems for industrial applications, *Engineering Applications of Artificial Intelligence* 21, 2008, pp. 331–342.
- [2] J.G. Lee, S.J. Hwang, S.W. Kim, S. Ahn, K.H. Park, J.H. Koo, W.S. Kang, Software architecture for a multi-protocol RFID reader on mobile devices, *Proceedings of the International Conference on Embedded Software and Systems*, 2005, pp. 8.
- [3] J. Lee, N. Kim, Performance test tool for RFID middleware: parameters, design, implementation, and features, *Proceedings of the International Conference Advanced Communication Technology* 1, 2006, pp. 149–152.
- [4] EPC Global, 2007, <http://www.epcglobalinc.org>.
- [5] Harrison, M., McFarlane, D., Parlikad, A.K., Wong, C.Y., Information management in the product lifecycle – the role of networked RFID, *Proceedings of the Second IEEE International Conference on Industrial Informatics INDIN 2004*, Berlin, Germany, pp. 507–512.
- [6] Teresko, J., *Winning the wireless*. Industry Week, June 1, 2003, <http://www.industryweek.com/Archive.aspx>.
- [7] Angeles, R., RFID technologies: supply-chain applications and implementation issues, *Information Systems Management* 22 (1), 2005, pp. 51–65.
- [8] Li, S., Visich, J.K., Radio frequency identification: supply chain impact and implementation challenges, *International Journal of Integrated Supply Management* 2 (4), 2006, pp. 407–424.
- [9] Saygin, C., Sarangapani, J., Grasman, S.E., *A Systems Approach to Viable RFID Implementation in the Supply Chain*, Springer Series in Advanced Manufacturing, 2007.
- [10] Michael, K., McCathie, L., The pros and cons of RFID in supply chain management, *Proceedings of the International Conference on Mobile Business*, 2005, pp. 623–629.
- [11] Banks, J., Hanny, D., Pachano, M.A., Thompson, L.G., *RFID Applied*. John Wiley & Sons, Inc., 2007.
- [12] Chow, H.K.H., Choy, K.L., Lee, W.B., Lau, K.C., Design of a RFID case-based resource management system for warehouse operations, *Expert Systems with Applications* 30, 2006, pp. 561–576.
- [13] Tajima, M., Strategic value of RFID in supply chain management, *Journal of Purchasing and Supply Management* 13 (4), 2007, pp. 261–273.
- [14] Whitaker, J., Mithas, S., Krishnan, M.S., A field study of RFID deployment and return expectations, *Production and Operations Management* 16 (5), 2007, pp. 599–612.
- [15] Agarwal, V., *Assessing the benefits Auto-ID technology in the consumer goods industry*. Technical Report, Auto-ID center MIT, 2001.
- [16] McFarlane, D., Sarma, S., Chirn, J., Wong, C., Ashton, K., Auto ID systems and intelligent manufacturing control, *Engineering Applications of Artificial Intelligence* 16, 2003, pp. 365–376.
- [17] Bottani, E., Rizzi, A., Economical assessment of the impact of RFID technology and EPC system on the fast-moving consumer goods supply chain, *International Journal of Production Economics* 112, 2008, pp. 548–569.
- [18] Dutta, A., Lee, H., Whang, S., RFID and operations management: technology, value, and incentives, *Production and Operations Management* 16 (5), 2007, pp. 646–655.