

# Ratio-Dependent Food Chain Models with Three Trophic Levels

R. Kara<sup>1</sup>, M. Can<sup>2</sup>

**Abstract**—In this paper we study a food chain model with three trophic levels and Michaelis-Menten type ratio-dependent functional response. Distinctive feature of this model is the sensitive dependence of the dynamical behavior on the initial populations and parameters of the real world. The stability of the equilibrium points are also investigated.

**Keywords**—Food chain, Ratio dependent models, Three level models

## I. INTRODUCTION

THE term “ratio-dependent predation” is introduced [1] to describe situations in which the feeding rate of predators depends on the ratio of the number of preys to the number of predators rather than on prey density alone, as is the case in most classical models. One advantage of the ratio dependence is that they prevent paradoxes of enrichment and biological control predicted by classical models [2].

Experimental observations [3] suggest that prey dependent models are appropriate in homogeneous situations and ratio-dependent models are good in heterogeneous cases. By many investigators [3, 4] it has also been concluded that natural systems are closer to the models with ratio dependence than to the ones with prey dependence.

Generally, a ratio-dependent predator-prey model leads a system of nonlinear ordinary differential equations of the following form:

$$\begin{aligned} \dot{x} &= xF(x) - cyP\left(\frac{x}{y}\right), & x(0) > 0, \\ \dot{y} &= \left(-d + P\left(\frac{x}{y}\right)\right)y, & y(0) > 0. \end{aligned} \quad (1)$$

If  $F(x) = r\left(1 - \frac{x}{K}\right)$ ,  $P(x) = \frac{mx}{a+x}$ , then (1) becomes a ratio-dependent predator-prey model with Michaelis-Menten type functional response:

$$\begin{aligned} \dot{x} &= \left(r\left(1 - \frac{x}{K}\right) - \frac{cm_y}{x + ay}\right)x, & x(0) > 0, \\ \dot{y} &= \left(-d + \frac{mx}{x + ay}\right)y, & y(0) > 0. \end{aligned} \quad (2)$$

Analysis of (2) by Hsu, Hwang and Kuang [5], shows that the ratio-dependent models are capable of producing far richer and biologically more realistic dynamics. Specifically, they do not produce the paradoxes of biological control and enrichment. It also allows mutual extinction as a possible outcome of a given predator-prey interaction.

## II. FOOD CHAIN MODELS WITH THREE TROPHIC LEVELS

The classical food chain models with only two trophic levels are insufficient to produce realistic dynamics. Therefore we consider the following three trophic levels food chain model with ratio-dependence:

$$\begin{aligned} \dot{x} &= \left(r\left(1 - \frac{x}{K}\right) - \frac{1}{\eta_1} \frac{m_1 y}{x + a_1 y}\right)x, & x(0) > 0, \\ \dot{y} &= \left(\frac{m_1 x}{x + a_1 y} - d_1 - \frac{1}{\eta_2} \frac{m_2 z}{y + a_2 z}\right)y, & y(0) > 0, \\ \dot{z} &= \left(-d_2 + \frac{m_2 y}{y + a_2 z}\right)z, & z(0) > 0. \end{aligned} \quad (3)$$

where  $x, y, z$  stand for the population density of the prey, predator and top predator. For  $i = 1, 2$ ,  $\eta_i, m_i, a_i, d_i$  are the yield constants, maximal predator growth rates, half-saturation constants and predators' death rates,  $r$  and  $K$  are the prey intrinsic growth rate and carrying capacity, respectively.

(3) is a simple relation between the populations of the three species:  $z$  prey on  $y$  and only  $y$ , and  $y$  prey on  $x$  and nutrient recycling is not accounted for. For simplicity, we non-dimensionalize the system (3) along the following scaling:

$$\begin{aligned} t &\rightarrow rt, & x &\rightarrow \frac{x}{K}, & y &\rightarrow \frac{a_1}{K} y, & z &\rightarrow \frac{a_1 a_2}{K} z, \\ m_1 &\rightarrow \frac{m_1}{r}, & d_1 &\rightarrow \frac{d_1}{r}, & m_2 &\rightarrow \frac{m_2}{r}, & d_2 &\rightarrow \frac{d_2}{r}, \end{aligned}$$

to reduce the system (4) into

<sup>1</sup> Istanbul Technical University, Faculty of Arts and Sciences, Mathematics Department, 34469 Istanbul Turkey, rkara@itu.edu.tr

<sup>2</sup> International University of Sarajevo, Faculty of Engineering and Natural Sciences, Paromlinska 66, 71000 Sarajevo, Bosnia Herzegovina, mcan@ius.edu.ba

$$\begin{aligned} \dot{x} &= \left(1 - x - \frac{c_1 y}{x+y}\right) x, & x(0) > 0, \\ \dot{y} &= \left(\frac{m_1 x}{x+y} - d_1 - \frac{c_2 z}{y+z}\right) y, & y(0) > 0, \\ \dot{z} &= \left(-d_2 + \frac{m_2 y}{y+z}\right) z, & z(0) > 0. \end{aligned}$$

Where  $c_1 \rightarrow \frac{m_1}{\eta_1 a_1 r}$ ,  $c_2 \rightarrow \frac{m_2}{\eta_2 a_2 r}$ .

### III. EQUILIBRIUM POINTS

Considering the nonnegative ness of the parameters and unknowns, we get two equilibrium points. One of them is of the form  $E_0(\bar{x}, \bar{y}, 0)$  and the other is  $E_1(x^*, y^*, z^*)$ .

The Equilibrium Point  $E_0(\bar{x}, \bar{y}, 0)$

The first equilibrium point  $E_0(\bar{x}, \bar{y}, 0)$  with

$$\bar{x} = 1 - c_1 + \frac{c_1 d_1}{m_1}, \bar{y} = \frac{(m_1 - d_1)(m_1(1 - c_1) + c_1 d_1)}{d_1 m_1}, \bar{z} = 0 \quad (6)$$

is a nonnegative equilibrium point of the system (2.2) if

$$m_1(1 - c_1) + c_1 d_1 > 0 \quad \text{and} \quad m_1 > d_1. \quad (7)$$

The Equilibrium Point  $E_1(x^*, y^*, z^*)$

The second equilibrium point  $E_1(x^*, y^*, z^*)$  with

$$x^* = 1 - c_1 \left(1 - \frac{1}{B}\right), \quad y^* = (B - 1) \left(1 - c_1 \left(1 - \frac{1}{B}\right)\right) \quad (8)$$

$$z^* = (B - 1) \left(1 - c_1 \left(1 - \frac{1}{B}\right)\right) \left(\frac{m_2}{d_2} - 1\right),$$

$$B = \frac{m_1}{d_1 + c_2(1 - d_2/m_2)}$$

is an interior equilibrium of the system (5) if

$$c_1 \left(1 - \frac{1}{B}\right) < 1, \quad B > 1, \quad \text{and} \quad d_2 < m_2.$$

### IV. STABILITY OF EQUILIBRIUMS

The dynamical behavior of equilibrium points is studied by computation of the eigenvalues of the variational matrix  $J$ ;

$$(5) \quad \begin{bmatrix} 1 - 2x - \frac{c_1 y^2}{(x+y)^2} & -\frac{c_1 x^2}{(x+y)^2} & 0 \\ \frac{m_1 y^2}{(x+y)^2} & -d_1 + \frac{m_1 x^2}{(x+y)^2} - \frac{c_2 z^2}{(y+z)^2} & -\frac{c_2 y^2}{(y+z)^2} \\ 0 & \frac{m_2 z^2}{(y+z)^2} & -d_2 + \frac{m_2 y^2}{(y+z)^2} \end{bmatrix} \quad (9)$$

at each equilibrium point.

For the equilibrium point  $E_0$ : The eigenvalues are:

$$\lambda_1 = \frac{1}{2m_1^2} (L + \sqrt{M}), \quad \lambda_2 = \frac{1}{2m_1^2} (L - \sqrt{M}), \quad \lambda_3 = -d_2 + m_2.$$

Where  $L = d_1^2(m_1 - c_1) - m_1^2(1 - c_1 + d_1)$ , and

$$M = L^2 + 4m_1^2 d_1 (d_1 - m_1)(m_1(1 - c_1) + c_1 d_1).$$

When  $E_0$  is a nonnegative equilibrium point of the system (5),  $m_1(1 - c_1) + c_1 d_1 > 0$  and  $m_1 > d_1$ . Hence one has  $4m_1^2 d_1 (d_1 - m_1)(m_1(1 - c_1) + c_1 d_1) < 0$ , and therefore

$$\lambda_1 \lambda_2 = \frac{L^2 - M}{4m_1^4} = -4m_1^2 d_1 (d_1 - m_1)(m_1(1 - c_1) + c_1 d_1) > 0.$$

That is the roots have the same sign if they are real. On the other hand if  $L > 0$  one also has

$$\lambda_1 + \lambda_2 = \frac{L}{m_1^2} > 0.$$

That is  $\lambda_1, \lambda_2 > 0$  if the roots are real and  $\Re(\lambda_1) = \Re(\lambda_2) > 0$  if the two roots are complex conjugate. If  $m_2 > d_2$ , then  $\lambda_3 > 0$  and in this case  $E_0$  is a repeller point. If  $m_2 < d_2$ , one has  $\lambda_3 < 0$  then  $E_0$  is saddle point, that is,  $E_0$  is unstable in both cases.

On the other hand, if  $L < 0$ , then  $\lambda_1, \lambda_2 < 0$  if the two roots are real.  $\Re(\lambda_1) = \Re(\lambda_2) < 0$  if the two roots are complex conjugate. If  $m_2 > d_2$  then  $\lambda_3 > 0$  and  $E_0$  is saddle point. If  $m_2 < d_2$ , then  $\lambda_3 < 0$  and  $E_0$  is spiral node.

When  $m_2 < d_2$ ,  $E_1$  does not lie in the physical space. Hence the system can not have two stable equilibrium points for the same set of parameters.

For the equilibrium point  $E_1$ : It can be shown that the real parts of the roots of the cubic algebraic equation  $\lambda^3 + A_1 \lambda^2 + A_2 \lambda + A_3 = 0$  with real coefficients are all with negative real parts if and only if  $A_1, A_2, A_3 > 0$  and  $A_1 A_2 > A_3$ .

For the Jacobi matrix  $J(E_1) = \begin{bmatrix} a_{11} & a_{12} & 0 \\ a_{21} & a_{22} & a_{23} \\ 0 & a_{32} & a_{33} \end{bmatrix}$ ,

one has

$$\begin{aligned} A_1 &= -a_{11} - a_{22} - a_{33}, \\ A_2 &= a_{22}a_{33} + a_{11}a_{22} + a_{11}a_{33} - a_{12}a_{21} - a_{23}a_{32}, \\ A_3 &= a_{12}a_{21}a_{33} + a_{11}a_{23}a_{32} - a_{11}a_{22}a_{33} \end{aligned}$$

Using equilibrium conditions obtained from (5), we see that

$$\begin{aligned} a_{11} &= x \left( -1 + \frac{c_1 y}{(x+y)^2} \right), \quad a_{22} = y \left( -\frac{m_1 x}{(x+y)^2} + \frac{c_2 z}{(y+z)^2} \right), \\ a_{33} &= \frac{m_2 y z}{(y+z)^2}, \quad a_{12} = \frac{-c_1 x^2}{(x+y)^2}, \quad a_{21} = \frac{m_1 x^2}{(x+y)^2}, \\ a_{23} &= \frac{-c_2 y^2}{(y+z)^2}, \quad a_{32} = \frac{m_2 z^2}{(y+z)^2}. \end{aligned}$$

It can be shown that the coefficients  $A_1, A_2, A_3$  satisfy the inequalities  $A_1, A_2, A_3 > 0$  and  $A_1 A_2 > A_3$  if

$$\frac{c_1 y^*}{(x^* + y^*)^2} < 1, \quad \frac{c_2 z^*}{(y^* + z^*)^2} < \frac{m_1 x^*}{(x^* + y^*)^2}$$

Therefore the characteristic equation of the Jacobi matrix (9) has roots with all negative real parts, and hence  $E_1$  is a stable equilibrium point under these conditions.

### V. NUMERICAL EXPERIMENTS

The numerical experiments are designed to show the dynamical behavior of the system in three main different sets of parameters: I.  $E_0$  is stable while  $E_1$  is an unstable equilibrium point. II.  $E_1$  is stable while  $E_0$  is an unstable equilibrium point. III.  $E_0, E_1$  are both unstable equilibrium points.

I.  $E_0$  is stable,  $E_1$  is unstable: For the parameter set  $\{c_1, c_2, d_1, d_2, m_1, m_2\} = \{1.0, 0.1, 0.2, 0.2, 2.1, 0.1\}$  the coordinates of equilibrium points are  $E_0 = (0.095, 0.905, 0.)$ ,  $E_1 = (0.048, 0.952, -0.476)$ . The eigenvalues are  $E_0 : \{0.095 + 0.091I, 0.095 - 0.091I, -0.100\}$ ,  $E_1 : \{-0.136, 0.110, -0.054\}$ . The solution is found not sensitive to the changes in the parameter set and in the initial conditions. For the initial data  $\{1.0, 2.0, 1.0\}$  the three dimensional plot of the solution is:

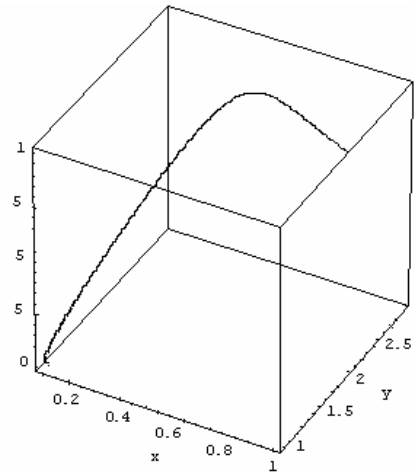

Fig. 1 The solution for the initial data  $\{1.0, 2.0, 1.0\}$

II.  $E_1$  is stable,  $E_0$  unstable. Three numerical experiments are set to reveal the sensitivity of the solution both to the changes in the initial conditions and in the parameter set.

First the parameter set  $\{c_1, c_2, d_1, d_2, m_1, m_2\} = \{1.000, 11.000, 1.000, 1.000, 10.000, 2.005\}$  the coordinates of equilibrium points are  $E_0 = (0.1, 0.9, 0.0)$ ,  $E_1 = (0.6514, 0.3486, 0.3504)$ . The eigenvalues are  $E_0 : \{1.005, -0.797, -0.113\}$ ,  $E_1 : \{-0.0003 + 1.2896 I, -0.0003 - 1.2896 I, -0.4458\}$ . For the initial data  $\{0.70, 0.40, 0.42\}$  the three dimensional plot of the solution is as follows:

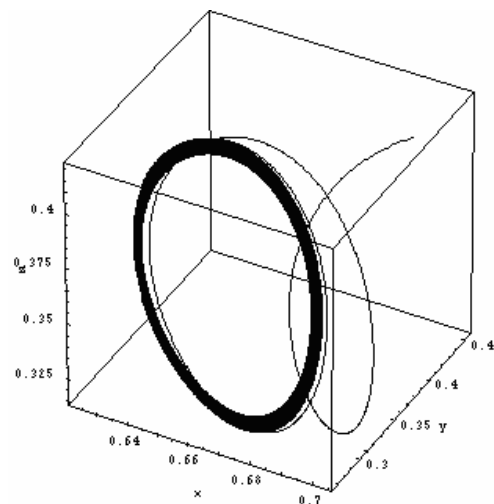

Fig. 2 The solution for the initial data  $\{0.70, 0.40, 0.42\}$

For large time this solution shrinks to a point.

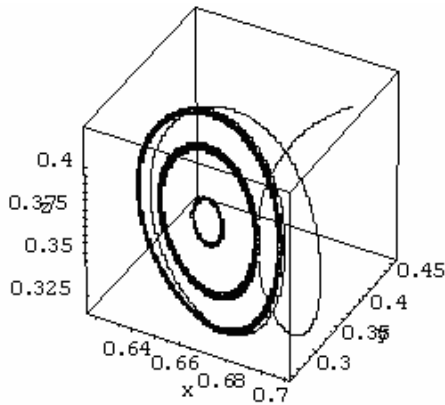

Fig. 3 The solution shrinks to a point by the time.

For a slightly different initial data  $\{0.70, 0.40, 0.45\}$ , we obtain a completely different solution:

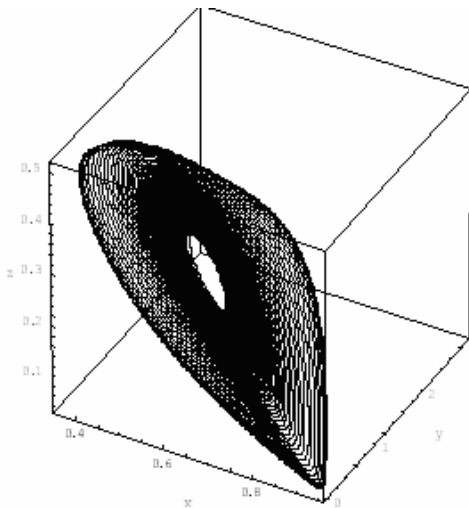

Fig. 4 The solution for the slightly different initial data  $\{0.70, 0.40, 0.45\}$ .

For large time this solution approaches to the following limit cycle with period 8.23.

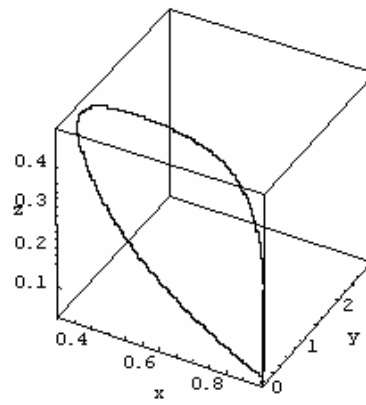

Fig. 5 This solution approaches to an internal limit cycle with period 8.23.

On the other hand if we slightly change the parameter  $m_2$ , for the the parameter set

$$\{c_1, c_2, d_1, d_2, m_1, m_2\} = \{1.000, 11.000, 1.000, 1.000, 10.000, 1.500\}$$

the coordinates of equilibrium points are  $E_0 = (0.1, 0.9, 0.0)$ ,  $E_1 = (0.467, 0.533, 0.267)$ .

The eigenvalues are  $E_0 : \{-0.797, 0.500, -0.113\}$ ,

$E_1 : \{-0.1637 + 1.190 I, -0.1637 - 1.190 I, 0.110, -0.2682\}$

The solution is still sensitive to the changes in the initial conditions, and for the initial data given in

$$E_1 = (0.467, 0.533, 0.267)$$

the three dimensional plot of the solution is as follows:

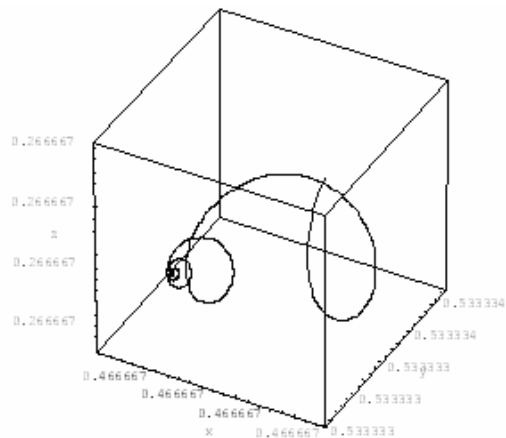

Fig. 6 The solution for a slightly different  $m_2 = 1.500$ .

While for an initial data given away from  $E_1 = (0.467, 0.533, 0.267)$ , the three dimensional plot of the solution is qualitatively different from the one in the above:

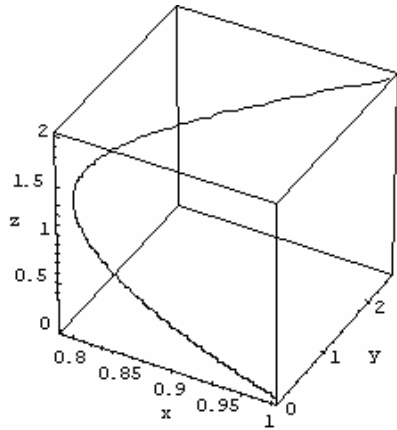

Fig. 7 The solution for the different initial data  $\{1.0, 2.5, 2.0\}$ .

III.  $E_1$  and  $E_0$  are both unstable.

Numerical experiments are set to reveal the sensitivity of the solutions both to the changes in the initial conditions and in the parameter set. First we keep all parameters as in the case II except  $m_2$ , change  $m_2$  slightly towards the instability of  $E_1$  and take

$$\{c_1, c_2, d_1, d_2, m_1, m_2\} = \{1.000, 11.000, 1.000, 1.000, 10.000, 2.008\}$$

then the coordinates of equilibrium points are  $E_0 = (0.1, 0.9, 0.0)$ ,  $E_1 = (0.6522, 0.3478, 0.3506)$ .

The eigenvalues are

$$E_0 : \{1.0080, -0.7971, -0.1129\},$$

$$E_1 : \{0.0005 + 1.2893 I, 0.0005 - 1.2893 I, -0.4467\}.$$

For the initial data given in  $E_1 = (0.6522, 0.3478, 0.3506)$ , the three dimensional plot of the solution is an enlarging spiral:

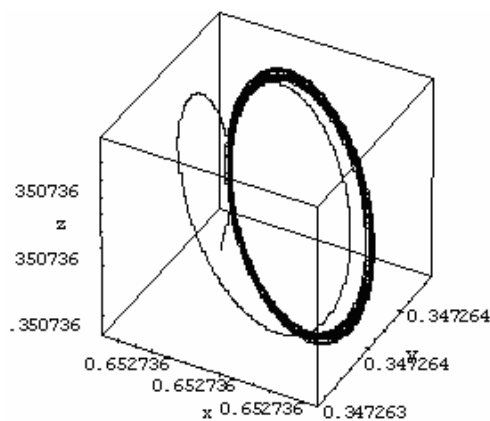

Fig. 8 For the initial data given in  $E_1$ , the solution is an enlarging spiral.

The following figure shows how spiral enlarges in the time. It is surprising enough that the statistical work on the motion gives an almost constant period 4.87.

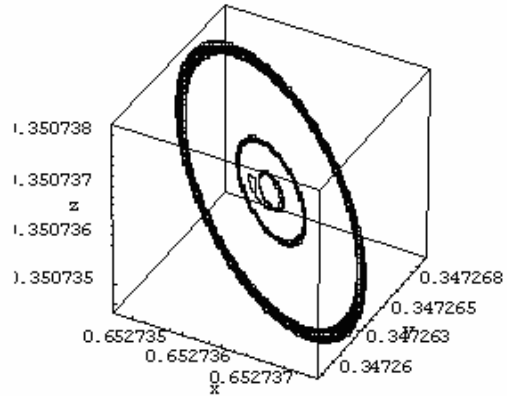

Fig. 9 Solution spiral enlarges in the time keeping a constant period 4.87.

While for an initial data given a little bit away from  $E_1$ , we obtain a solution which is qualitatively completely different from the one in the above:

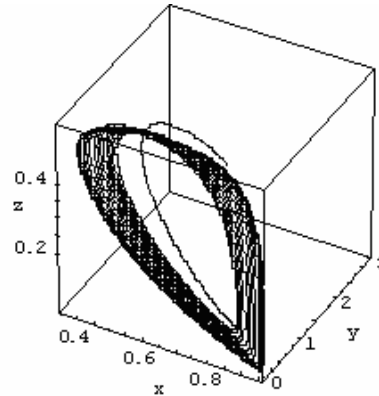

Fig. 10 The solution for the different initial data  $\{0.7, 1.4, 0.4\}$  a little bit away from  $E_1$ .

For large time this solution approaches to the following limit cycle with period 8.43 as in the stable  $E_1$  case.

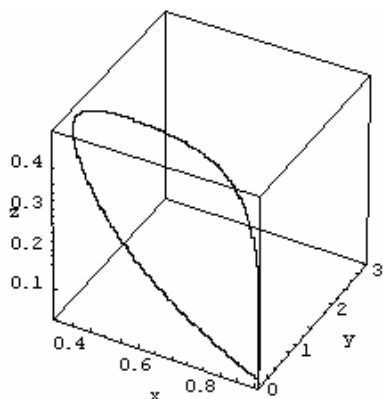

Fig. 11 For large time this solution approaches to an inner limit cycle with period 8.43

For an initial data  $\{2., 2., 2.\}$  given away from  $E_1$ , one obtains a solution which is completely different from the ones in the above, the solution stops when the top predator disappears:

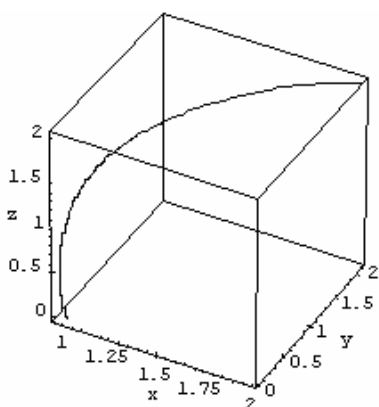

Fig. 12 The solution stops when the top predator disappears

On the other hand if the parameter set is chosen far away of the transition regions, we obtain solutions which are not sensitive to the changes in the initial conditions and in the parameter set.

For the parameter set  $\{c_1, c_2, d_1, d_2, m_1, m_2\} = \{1.0, 11.0, 1.0, 1.0, 10.0, 2.3\}$

the coordinates of equilibrium points are  $E_0 = (0.10, 0.90, 0.)$ ,  $E_1 = (0.7217, 0.2783, 0.3617)$ .

The eigenvalues are  $E_0 : \{1.3000, -0.7971, -0.1129\}$ ,

$E_1 : \{0.0696 + 1.2409 I, 0.0696 - 1.2409 I, 0.110, -0.5304\}$ .

The solution is found not sensitive to the changes in the parameter set and in the initial conditions. For the initial data

$\{0.8, 0.1, 0.3\}$  the solution stops when the top predator disappears and the three dimensional plot of the solution is:

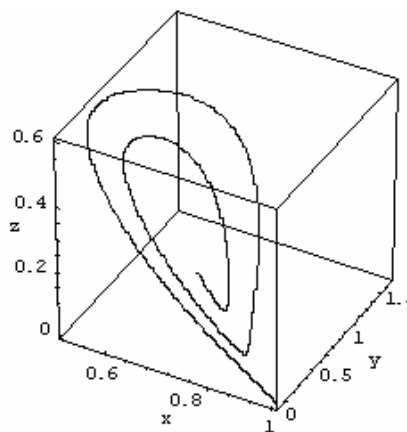

Fig. 13 The solution stops when the top predator disappears.

## VI. CONCLUSION

In this study, ratio-dependent food chain model is analyzed and possible dynamical behavior of this system investigated at equilibrium points. It has been shown that, in certain regions of the parameter space, ratio dependent food chain model is sensitively depending on the parameter values and initial conditions. That is a very small change in these values, produces unpredictable results. Another property of the nonlinear systems also experienced during the calculations, long-term predictions are impossible.

## REFERENCES

- [1] Arditi, R., Ginzburg, L. R., "Coupling in predator-prey dynamics: ratio-dependence", *J. Theoretical Biology* 139:311-326, 1989.
- [2] Arditi, R., Saiah, H., "Empirical evidence of the role of predator-prey theory", *Ecology* 73:1530-1535, 1992.
- [3] Ginzburg, L. R., Akçakaya, H. R., "Consequences of ratio-dependent predation for steady state properties of ecosystems", *Ecology* 73:1536-1543, 1992.
- [4] McCarthy, M. A., Ginzburg, L. R., Akçakaya, H. R., "Predator interference across trophic chains.", *Ecology* 76(4):1310-1319, 1995.
- [5] Hsu, S. B., Hwang, T. W., Kuang, Y., "Global analysis of the Michaelis-Menten type ratio-dependence predator-prey system.", *J. Math. Biol.* 42:489, 2001.