

An Experimental Study of Tip Vortex Cavitation Inception in an Axial Flow Pump

Mohammad Taghi Shervani Tabar, Zahra Poursharifi

Abstract—The interaction of the blade tip with the casing boundary layer and the leakage flow may lead to a kind of cavitation namely tip vortex cavitation. In this study, the onset of tip vortex cavitation was experimentally investigated in an axial flow pump. For a constant speed and a fixed angle of attack and by changing the flow rate, the pump head, input power, output power and efficiency were calculated and the pump characteristic curves were obtained. The cavitation phenomenon was observed with a camera and a stroboscope. Finally, the critical flow region, which tip vortex cavitation might have occurred, was identified. The results show that just by adjusting the flow rate, out of the specified region, the possibility of occurring tip vortex cavitation, decreases to a great extent.

Keywords—Axial flow pump, Gap cavitation, Leakage vortex, Tip vortex cavitation.

I. INTRODUCTION

IMPROVEMENTS in hydraulic machines design have led to much better control of cavitation effects. Consequently, different kinds of cavitation phenomena which were not much considered in the past are attracting more attention. Among these, tip clearance and tip vortex cavitation are becoming prominent topics. Delaying or eliminating these two types of cavitation (entirely or partially) is a major goal in design of axial flow pumps, due to their undesirable consequences such as noise, vibrations, mechanical damage and power loss [1].

Water or any other liquid vaporizes at certain temperature and pressure (vapor pressure). If the pressure is reduced to a pressure lower than the vapor pressure, the liquid starts to evaporate. As the liquid flows within the pump impellers, if the liquid pressure reduces to a level lower than the vapor pressure of the liquid at the working temperature, vapor bubbles are formed. These bubbles will move along with the flow to the other parts with higher pressure. If the pressure at the new location is high enough, these vapor bubbles collapse. In this case, cavities are formed in the liquid, causing other liquid particles to deviate from their paths and hit other surfaces like impeller blades with a very high impact speed.

In these locations on the surfaces, depending on the severity of the impact, erosion occurs on the blades and the surface becomes porous. The growth and collapse of these vapor bubbles is called cavitation [2].

Mohammad Taghi Shervani Tabar is with the Department of Mechanical Engineering, Tabriz University, Tabriz, Iran (e-mail: msherv@tabrizu.ac.ir).

Zahra Poursharifi is with the Department of Mechanical Engineering, Tabriz University, Tabriz, Iran (e-mail: z.poursharifi@gmail.com).

An important type of cavitation seen usually in axial flow pumps is the tip vortex cavitation. One of the complex problems associated with operation of pumps is this kind of cavitation. The relative motion of a blade and the casing requires a finite clearance between the blade tip and the end-wall to avoid rubbing. This relative motion of the blade tip, the end-wall and the pressure difference across the blade tip create the tip clearance flow. The tip clearance flow between the rotor tip and the end-wall intersects the flow over the suction side of the blade which has a different magnitude and direction. These two flows form a vortex sheet which eventually rolls up to form the leakage vortex. Axial-flow pumps and compressors are subject to many of the same design considerations in regard to tip clearance flows; however for pumps, which are liquid handling machinery, the interaction of the blade tip with the casing boundary layer and the leakage flow may lead to cavitation. Cavitation occurring in the tip clearance of an axial-flow pump can be classified into three types: gap, blade-end and leakage vortex cavitation. Gap cavitation occurs in the clearance itself due to separation of the clearance flow as it travels around the blade end. It is usually prevented by rounding the intersections of the leading edge and pressure surface. Blade-end cavitation occurs at the leading edge when clearances are small and primarily is due to the stretching of boundary layer vorticity. Leakage vortex cavitation results from the low pressure region in the vortex formed by the interaction of the clearance flow with the through-flow [3].

A study on tip clearance and tip vortex cavitation were done by R.laborde et al. [1]. Their experimental research was about investigating the cavitation patterns and cavitation inception in an axial flow pump. They also studied the topic for various gap heights, clearance, blade geometries and rotor operating conditions. It was found that the gap height and clearance geometry have less influence on tip vortex cavitation but forward and backward blade skew is observed to reduce and increase tip vortex cavitation respectively, as compared to a blade with no skew. K. J. Farrell et al. [3] found a correlation which predicts the inception index for leakage vortex cavitation as a function of blade geometry and flow variables for axial flow pumps. They also identified an optimum tip clearance, theoretically. However, some of the studies about tip vortex cavitation are mainly concerned with single hydrofoils. Higashi et al. [4] carried out experimental and numerical studies about tip vortex cavitation. Their main research was on tip leakage vortex cavitation of a single hydrofoil with tip clearance. They discussed the influence of

the cavitation number, angle of attack, blade loading distribution, and the size of tip clearance. Further, the interaction of gas bubbles with a vortex was investigated by Lattore et al. [5]. Their study was done experimentally to clarify the role of the initial bubble position on its trajectory around the tip vortex shed from a large single hydrofoil. Experiment investigation on the onset of tip vortex cavitation, was done by Couty et al. [6]. As an important result, the complex physical mechanism of cavitation vortex collapse was presented in their work. In this paper, an experiment was developed to investigate the tip vortex cavitation inception in an axial pump. A stroboscope and a camera was utilized to observe the region, which tip vortex cavitation might have occurred. The flow parameters such as flow rate, suction pressure, discharge pressure and dynamic force were recorded at each step.

II. EXPERIMENTAL SETUP

In order to test the axial flow pump's performance under cavitation, a closed loop system including an axial flow pump was used. A schematic figure of the hydraulic equipments is illustrated in Fig. 1.

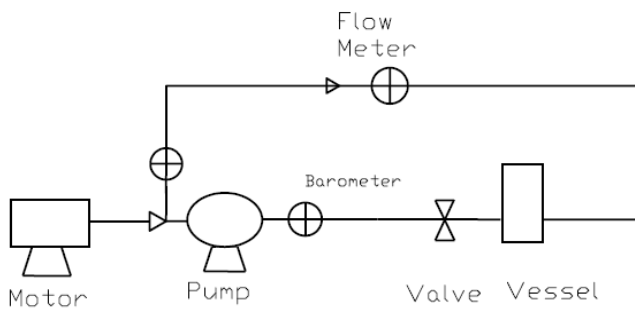

Fig. 1 Axial flow pump test region

The impeller has 4 vanes, which are adjustable and can be set at several different angles. For this specific test, the inlet flow angle is set at 15 degrees. The pump tested is driven by a D.C. electro motor, whose rated power is 22 kWatts. And its nominal speed is 1440 rpm. But the rotational speed can be set at 980 rpm too. For all steps of the test procedure, the rotational speed of the rotor is chosen to be 980 rpm. Pump's casing which is made of plexi-glass material, makes it possible to observe the pattern of fluid flow inside the pump. A manual valve is utilized to control the flow rate. The working fluid is tap water with an approximate density of $1000 \text{ Kg} / \text{m}^3$. There are two distinct barometers to measure the suction pressure and the discharge pressure. The capacity of the pump is measured by an analog flow meter. By means of some balancing weights, pump's shaft torque is measurable. For further understanding and interpretation of the subject, a digital camera and a stroboscope were utilized to record the flow pattern.

III. RESULTS AND DISCUSSION

As mentioned above, the flow parameters were recorded and also the patterns of the cavitation phenomenon were observed. The cavity patterns are explained and then the results are discussed.



(a)



(b)



(c)



(d)



(e)

Fig. 2 Cavitation patterns in the axial flow pump for different flow rates: a- Q=140 lit/sec, b- Q=132 lit/sec, c- Q=120 lit/sec, d- Q=95 lit/sec and e- Q=72 lit/sec.

Head:

$$h_p = \frac{P_2}{\rho g} - \frac{P_1}{\rho g} \quad (1)$$

Input Power:

$$P_{in} = F \times R \times \frac{2\pi N}{60} \quad (2)$$

Output Power:

$$P_{out} = \rho g \times Q \times h_p \quad (3)$$

Efficiency:

$$\eta_P = \frac{P_{out}}{P_{in}} \quad (4)$$

Fig. 2(a) illustrates the first step of the test. Here, the flow rate is adjusted at Q=140 lit/sec. The suction pressure, discharge pressure and the force required for calculating input power were recorded -0.05 mH₂O, 0.8 mH₂O and 8.0 kgF, respectively. As it can be seen no signs of cavitation are visible here proving that the cavitating process has not started yet. Fig. 2(b) shows the second step. After decreasing the flow rate to Q=132 lit/sec, the suction pressure, discharge pressure and the force required for calculating input power were recorded -0.01 mH₂O, 1.1 mH₂O and 8.2 KgF, respectively. As shown in the figure, small cavities are formed along the airfoil. These cavity bubbles are shed in an embowed form along the blade. In this step, tip vortex cavitation occurs obviously. Fig. 2(c) illustrates the third step of the experimental test. Here, the cavity develops as the flow rate decreases. By decreasing the flow rate to Q=120 lit/sec, the developing rate of the cavity bubbles increase and the cavitation phenomena completely becomes dominant. In this step, the suction pressure, discharge pressure and the force required for calculating input power were found to be -0.7 mH₂O, 1 mH₂O and 9.1 kgF, respectively. In comparison with the previous step, the number of cavity bubbles has increased and they have become larger. Thus, this type of cavitation can be recalled as developed type of cavitation. Fig. 2(d) shows the results at Q=95 lit/sec. In this step, the suction pressure, discharge pressure and the force required for calculating input power were recorded -1.8 mH₂O, 0.5 mH₂O and 10.5 kgF, respectively. Unstable cavitation is thoroughly visible in this step of experiment. This type of cavitation is brought about by shedding of large scale bubbly cavities but disappears soon. Fig. 2(e) illustrates the final step of the experimental test for Q=72 lit/sec. The suction pressure, discharge pressure and fluid dynamic force were recorded -2.5 mH₂O, 0 mH₂O and 10.8 kgF, respectively. In this step, the cavities developed at the center of the airfoil move toward the forward side of it and this causes a combined form of cavitation and tip vortex cavitation and gap cavitation occur simultaneously. According to (1)-(4), pump characteristic curves were depicted. The results have been shown in Fig. 3.

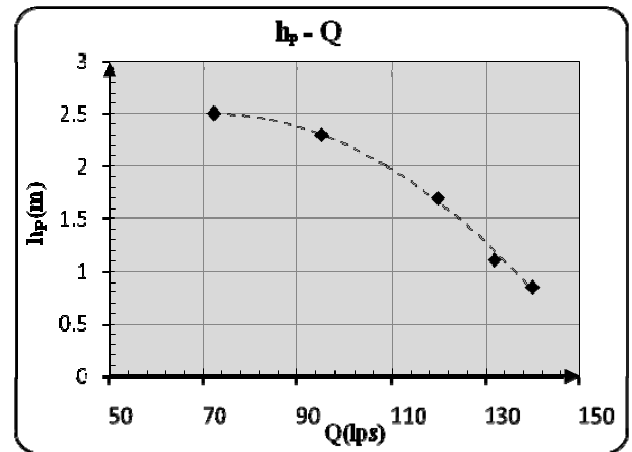

(a)

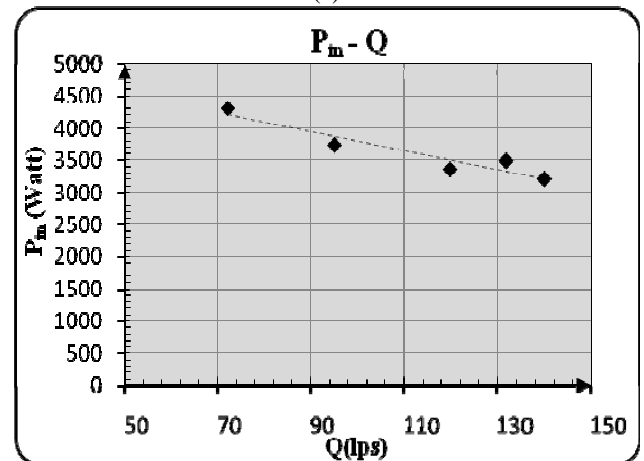

(b)

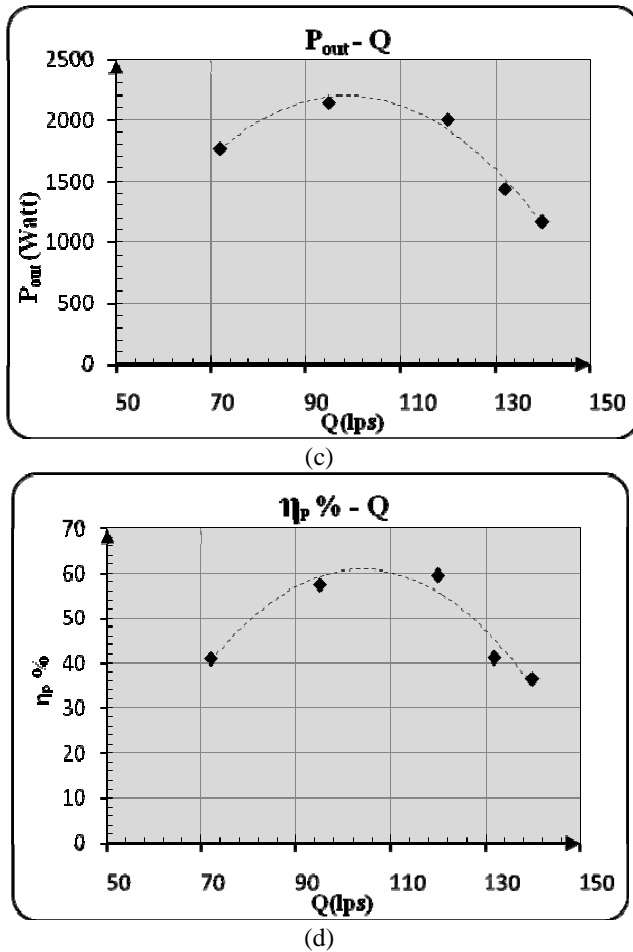

Fig. 3 Pump characteristic curves; a- Head versus flow rate, b- Input power versus flow rate, c- Output power versus flow rates, d- Efficiency versus flow rate.

Fig. 3(a) illustrates the variations of the head of pump with flow rate. Generally this curve is a descending parabolic; as the flow rate increases, the value of head decreases. At axial flow pumps, maximum flow rates are critical points for cavitation and subsequently, tip vortex cavitations. Fig. 3-(b) shows the variations of input power. The experiments were carried out at a constant speed of $N=980$ rpm and the length of the arm was equal to $R=0.4$ m. Thus, according to (2), the only parameter that affects the input power is the fluid dynamic force (F). The value of F decreases when the flow rate increases. Thus, as expected this curve is a descending one too. Fig. 3(c) represents the variations of output power with flow rate. According to (2) and by assuming g as a constant, it is obvious that the value of P_{out} is simultaneously affected by the values of Q and P_{out} . As it can be seen, at lower flow rates, as the flow rate increases to $Q=100$ lit/sec, the output power increases too. It can be understood that in this region of Q , increasing of Q is more dominant in comparison with the decreasing of h_p ; but increasing Q to values more than 100 lit/sec, leads to decreasing of P_{out} and though in this region, the decreasing of h_p has dominated the

increasing of Q . It is found that by approaching the cavitation zone, the effects of cavitation on decreasing of h_p , shows its significance. Fig. 3(d) shows the variations of efficiency with Q . Generally, this kind of curve for pumps has a maximum point, which is named as the best efficiency point. This point specifies pump characteristics of pump in designing procedure. In the present experiment, the maximum efficiency exists at flow rates, ranging from 100 to 125 lit/sec. It is to be noted here that for those values of Q which are out of this region, the efficiency decreases. These results reveal as the flow rate increases to values more than 125 lit/sec, approaching the cavitation zone, decreasing of efficiency becomes more sensible like the variations of P_{out} .

IV. CONCLUSION

In this study, the onset of tip vortex cavitation in an axial flow pump was experimentally investigated. Cavitation patterns were observed and cavitation inception was determined for various flow rates. Generally, the most important parameters which affect the formation of this kind of cavitation are the pressure difference along the airfoil, clearance geometry, gap height and tip sharpness. In this study, the flow rate was used as a controlling parameter for this kind of cavitation. The results show that tip vortex cavitation can directly lead to losses in efficiency, especially for flow rates inside the cavitation zone. Also tip vortex cavitation occurs at maximum flow point and by approaching the cavitation zone, the effect of cavitation on decreasing of pump head is revealed more significantly. Finally, as an important result, just by adjusting the flow rate out of the critical region, tip vortex cavitation is avoidable to a great extent.

REFERENCES

- [1] R.Laborde, P.Chantrel, and M.Mory., "Tip clearance and tip vortex cavitation in an axial flow pump", ASME J. Fluid. Eng., Vol.119, 1997.
- [2] A.Nourbakhsh, A.Jaumotte, Ch.Hirsch, and H.B.Parizi., "Turbopumps and Pumping Systems", Springer, 2008.
- [3] K. J., Farrel and M. L., Billet, "A correlation of leakage vortex cavitation in axial-flow pumps", ASME J. Fluid. Eng., Vol.116, 1994.
- [4] S.Higashi., Y.Yoshida, and Y.Tsujimoto, "Tip leakage vortex cavitation from the tip clearance of a single hydrofoil", JSME International Journal, Series B, Vol.45, No.3, 2002.
- [5] R.Lattore, J.Y.Billard, F.Mountan, and O.Roussel., "Bubble capture by large hydrofoil tip vortex", CAV2001; Sessions A6.002.
- [6] Ph.Couty, M.Farhat, and F.A.Vellan, "Physical investigation of a cavitation vortex collapse", CAV2001; Sessions A6.003.