

Micro-Controller based Oxy-Fuel Profile Cutting System

A. P. Kulkarni, P. Randive, and A. R. Mache

Abstract—In today's era of plasma and laser cutting, machines using oxy-acetylene flame are also meritorious due to their simplicity and cost effectiveness. The objective to devise a Computer controlled Oxy-Fuel profile cutting machine arose from the increasing demand for metal cutting with respect to edge quality, circularity and lesser formation of redeposit material. The System has an 8 bit micro controller based embedded system, which assures stipulated time response. A new window based Application software was devised which takes a standard CAD file .DXF as input and converts it into numerical data required for the controller. It uses VB6 as a front end whereas MS-ACCESS and AutoCAD as back end. The system is designed around AT89C51RD2, powerful 8 bit, ISP micro controller from Atmel and is optimized to achieve cost effectiveness and also maintains the required accuracy and reliability for complex shapes. The backbone of the system is a cleverly designed mechanical assembly along with the embedded system resulting in an accuracy of about 10 microns while maintaining perfect linearity in the cut. This results in substantial increase in productivity. The observed results also indicate reduced inter laminar spacing of pearlite with an increase in the hardness of the edge region.

Keywords—Computer-Control, Profile, Oxy-Fuel.

I. INTRODUCTION

BEFORE discovery of acetylene, metals were cut and welded by using oxy-hydrogen cutting process. In 1892 Major J. Turner Morehead and Thomas Wilson discovered acetylene which burned with great brilliancy. Oxy fuel cutting is thermal and chemical cutting process. Hence no tool wear takes place and also cutting forces generated are very much negligible. Moreover it uses lightweight fixtures which are very cost effective and consuming less time. CNC shape cutting machines are of two categories as small scale and large scale. In this paper small scale CNC shape cutting machines with oxy-fuel gas is discussed.

The drawing is generated in AutoCAD on standard platform with fixed limits and the application software analyzes the drawing which then extracts the co-ordinates of the drawing and sends in the form of specific command to the embedded system through the serial port. The system then controls the stepper motors to achieve the required movement and the desired position. Gantry type arrangement is made and X and Y movement are given by stepper motor. A Gas cutting torch is attached to the Y arm. The oxygen jet is controlled by 230 Volts solenoid valve which plays an important role in cutting process by removing ferrous oxide.

The machine is accurate to great extent. Linear accuracy is in the range of 10-micron. The complete system is explained in the coming sections.

II. GAS CUTTING

Gas cutting is a thermal cutting process in which cutting of the material takes place due to "oxidation" between metal and oxygen at high temperature. When the oxy-acetylene gas is used, cutting spot of the metal is heated till kindling temperature. This oxy-acetylene flame serves as the preheating flame. After heating to its kindling temperature a jet of pure oxygen is directed by pressing a lever on the cutting torch on the heating spot. With oxy-acetylene gas oxidation of metal is extremely rapid and part of the metal actually burns. The heat liberated by burning of the iron or steel melts the iron oxide formed due to chemical reaction and accelerates the preheating of the object being cut. The molten material runs off as slag exposing more iron or steel to the oxygen jet. The chemical reaction is as follows:

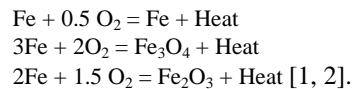

A. Cutting Process

The cutting process is illustrated in Fig. 1 given below.

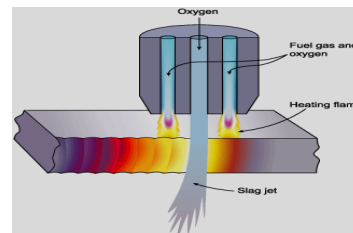

Fig. 1 Sectional View of oxy-fuel cutting process

A mixture of oxygen and the fuel gas is used to preheat the metal to its ignition temperature (bright red heat) but well below its melting point. A jet of pure oxygen is then directed into the preheated area. This triggers a vigorous exothermic chemical reaction between the oxygen and the metal to form Iron Oxide or slag. The oxygen jet blows away the slag enabling the jet to pierce through the material and continue to cut the material [2,4].

B. Oxy-Acetylene Gas Cutting Out Fit

An Oxy-Acetylene cutting set up usually consists of an acetylene cylinder, oxygen cylinder, two regulators, two hose pipes with fittings and a cutting torch with tips [5].

C. Oxy-Acetylene Oxidizing Flame

There are 3 types of flames namely Neutral Flame, Reducing Flame and Oxidizing Flame. Oxidizing flame used for cutting is adjusted with the help of natural flame by increasing oxygen or by decreasing acetylene till its inner cone is decreased to desire length. Fig. 2 shows the oxidizing flame [2].



Fig. 2 Oxidizing Flame (3482^o C)

III. EFFECT OF CUTTING PARAMETERS ON QUALITY OF CUT

The quality of cut depends mainly on parameters like cutting speed, oxygen pressure, type of nozzle selected.

A. Cutting Speed

The increase in cutting speed decreases the quality of the cut resulting in rounding of the bottom edge to some extent and also undercuts the edge which destroys the flatness. Also the slow speed results in unstable operation which causes gauges in the face of the cut. [2, 3, 6].

B. Oxygen Pressure

As the oxygen pressure goes up, the diameter of the stream increases comparatively faster than the increase in oxygen flow. This increases the width of cut and provides less oxygen to oxidize the steel which results in loss of quality. Also when oxygen pressure is less the gauging takes place and slag will not be removed from the surface of the metal. [2, 3, 6].

C. Nozzle

The use of oversized nozzles produces a cut that has considerable 'cut face' angle. The oversized oxygen stream expands as it passes through the plate. This results in the bottom of the cut being wider than the top. Increase in speed can reduce the cut width and face angle but at the cost of quality of surface. Smaller nozzles can be used to cut heavier thickness with dramatic reductions in speed with comparatively good quality [2, 3, 6].

IV. EXPERIMENTAL SETUP

In oxy acetylene cutting process cutting touch is not the "cutting tool". It only supplies homogeneous mixture of oxygen and acetylene to produce a flame. Since there is no contact between cutting torch and metal very small cutting forces are generated which is the very basis for the design of assembly.

A. Objective

To design low cost computer controlled automated machine which will give superior quality of cut. The CNC profile cutting system is meant for cutting Metal Plates of about 5 mm to 50 mm. AutoCAD .DXF file is used as input for application software.

B. Description of Assembly

The assembly is developed specially for the process. The assembly consisting of base frame of the machine is made up of M.S. angle and M.S. flat capable of bearing the load of cutting plate and driving system. Aluminum sections are used as a track and plastic wheels and roller bearing are used to minimize the friction. The special fixture (please refer Fig. 5) is developed so that it is convenient to hold cutting torch with nozzle. The fixture is attached to a trolley that gives Y movement. X and Y movements are given by a lead screw having "V" type threads and pitch of the screw 2 mm. The lead screw is fixed in between roller bearing. It receives power from two stepper motors through muff coupling. The rollers attached to the base frame are useful for facilitating the smooth movement of cutting plate after the cutting process. The weight of the assembly is around 37 Kg.

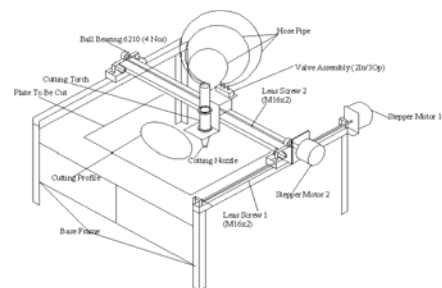

Fig. 3 Assembly

C. Embedded System Design

The application software is developed so that it is user friendly and can be used to simulate and display the relevant information prior to cutting operation for example the time to cut, cutting speed etc. Manual profile can also be cut using the control keys on keyboard.

It becomes more versatile since it uses standard CAD file like .DWG.

The design of the embedded system involves,

- Controlling the two Stepper motors in real time so that the linearity and accuracy during cutting can be maintained.
- Communication with the host computer
- Providing the required cutting logic and Manual Cutting facilities.
- Time stipulated response to assure reliable cutting.
- Design of the stepper motor driver circuitry to assure prolonged and optimized operation.

In this set up no sensors are used to make it cost effective. The dimensions of the actual cutting area are 0.8 M x 0.7 M.

So for such a large distance, errors in positioning are removed by creating a redundancy in the driving motor power. Since the mechanical driving component in the system consists of screw only inherent problems of backlash, position non-linearity etc. are eliminated. Also it requires less power to drive the system. Another factor, which again reduces the overall load on the driving screw, is the clever design of the mechanical chassis and the cutting gun holding platform. All these things assure an exact expected position of the cutting gun in the absence of the feedback system for the actual movement of the cutting gun.

Working block diagram of the embedded system is also shown if Fig. 4.

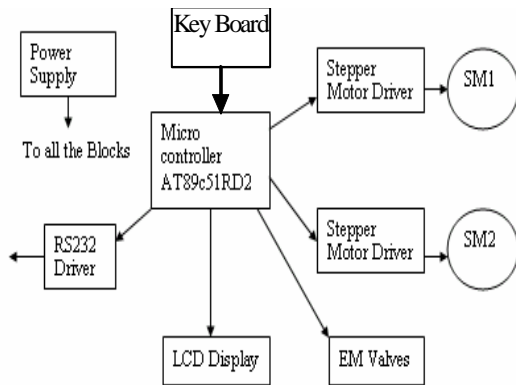

Fig. 4 Block diagram of proposed embedded system for Gas cutting

D. Stepper Motors

The stepper motors are used to move the XY table to achieve the required movement with the desired accuracy. Fig. 5 shows the stepper motors mounted on the specially designed setup.



Fig. 5 Stepper motor mounted on the setup

E. LCD Display

The 2 line 16 character LCD display is used to show the diagnostic /error messages and the informative messages to the user while doing the task.

F. RS232 Driver

The RS232 driver is used to connect the hardware to the PC to accept commands from the controlling Application software.

G. EM Valve

The valve is used to ON/OFF the gas supply to the cutting head.

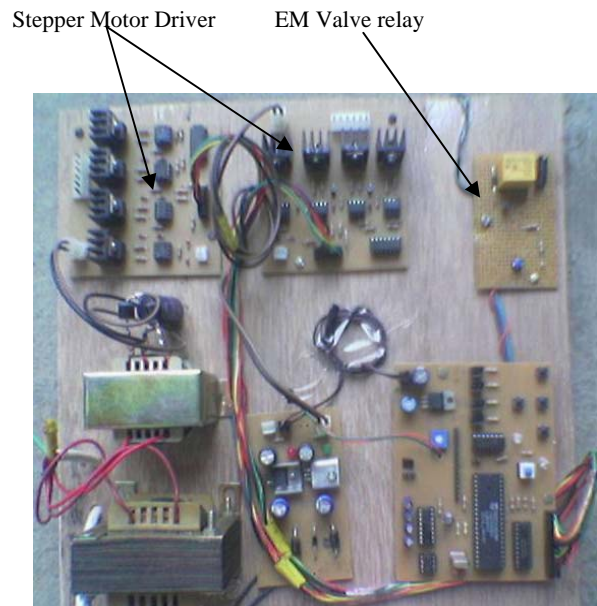

Fig. 6 Photograph of Control Board of the system

V. RESULTS

A. Software and Cut Profile

While performing the work the software window appears as shown in Fig. 7. After giving the shape it calculates coordinates and gives the required time estimate.

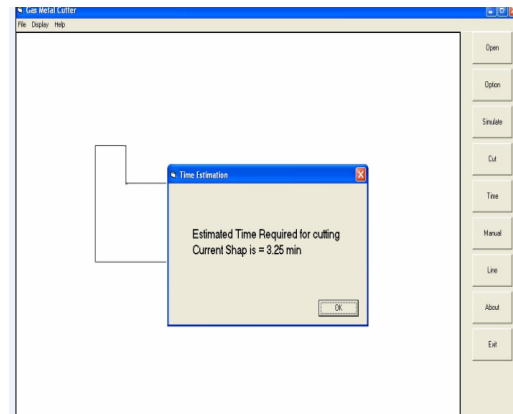

Fig. 7 Estimated time window

As the work progresses, the work done and remaining time is shown as below in Fig. 8.

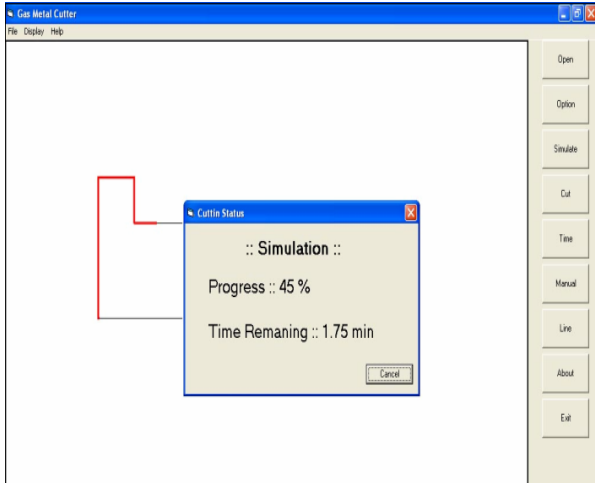

Fig. 8 Simulation window

The result of cut profile on the machine described here is shown below in Fig. 9.



Fig. 9 (a) 100 x 65 rectangular hole (b) Rectangular hole cutting (Automatic) (c) Cutting edge obtain in automatic

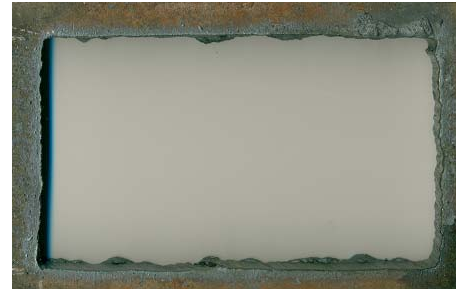

Fig. 10(a) 100 x 65 rectangular hole (b) Rectangular hole cutting (Manual) (c) Cutting edge obtain in manual cutting

The total time required for cutting of rectangular profile of size 100mm x 65 mm by our system is **3.03 min**. The result of cut profile on the manual operated machine described here is shown below in Fig. 15. The total time required for cutting of rectangular profile of size 100mm x 65 mm by manual cutting is **7.05min**.

B. Hardness

In automatic cutting heat input rate is more therefore cooling rate is slow. Auto transformation temperature increases in the vicinity of cutting zone. Therefore hardness of edge region is more as compared to manual cutting.

TABLE I
 MICRO HARDNESS RESULT

S. No	Sample Description	Hardness at Edge (VHN)	Hardness at Second region from edge (VHN)	Hardness base material (VHN)
1	Manual Cut Sample	225	158	165
2	Automatic Cut Sample	385	105	176

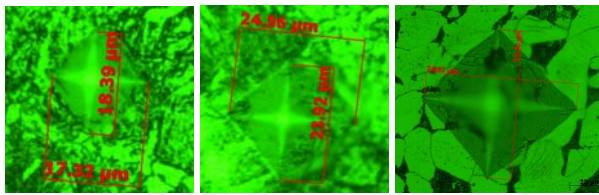

Fig. 11 Indintation at Edge region, Transient region and Base region (Automatic Cutting)

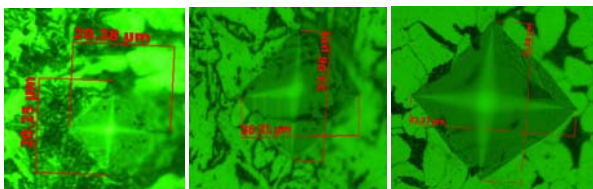

Fig. 12 Indintation at Edge region, Transient region and Base region (Manual Cutting)

- Inter laminar spacing of pearlite is reduced which increase the hardness of the edge region.
- Grain refinement is more in automatic at the edge region due to slow cooling so strength of the material increases therefore somewhat hardness is increased.
- In the second region of the sample cut automatic cutting, the blocky ferrite is formed due to very slow cooling rate due to which hardness decreases.
- In the second region of the sample cut by manual cutting acicular ferrite is formed. In this region the cooling rate is fast as compared to automatic cutting.
- Hardness of acicular ferrite is more as compared to blocky ferrite.
- Hardness of base material is near about same.

VI. CONCLUSION

After reviewing the results of the profile cutting machine, it is found that it is working as per the expectations with the accuracy of 10 micron, productivity of the system is approximately 200% more than conventional process and also the required time bounded by embedded system performed well with the least H/W as well as firmware complexity.

In automatic cutting heat input is high as compared to manual cutting; the heat affected zone observed is also more. Auto transformation temperature is more in the vicinity of edge. Inter laminar spacing of pearlite is reduced which increase the hardness of the edge region. Also grain refinement is more in this region, which increases strength as well as hardness. In the second region of automatic cutting sample the blocky ferrite is found having low hardness whereas in the second region of manual cutting sample acicular ferrite is found.

REFERENCES

- [1] Kjell-Arne Persson, AGA AB, Sweden, "Welding and Cutting Beyond The Year 2000", Svetsaren, A welding review published by The Esab Group Vol. 54 pp 74-76, 1-2 1999.
- [2] ESAB *Oxy-Acetylenecutting Handbook*.
- [3] Arnaud Paque, ESAB Cutting Systems, Karben, Germany, "Thermal Beveling Techniques", Svetsaren The Esab Welding And Cutting Journal Vol. 58 No.1.Pp 29-33. 2003
- [4] David Bell, Contributing Writer "Choosing the right Oxy-Acetylenegas and supply system" November 6, 2003 ESAB Welding and cutting products.
- [5] Dieter Lietze, "Safety Devices for Gas Welding, Cutting and Allied Processes", J. Loss Prev. Process hd. Vol. 8. No. 6. PP. 319-324, 1995
- [6] ESAB *Oxifuel manual cutting Hand book*.
- [7] H.Wang,P.Pranda,V.Hlavacek "Flame Focussing Modification Of a Wire Core Thermal Lance" October 2004 Welding Journal.
- [8] Sweetman, W. G. 1958. "Chemical cutting method and apparatus" U.S. patent no.2, 918,125.