

Sensorless PM Motor with Multi Degree of Freedom Fuzzy Control

Faeka M. H. Khater, Farouk I. Ahmed, and Mohamed I. Abu El- Sebah

Abstract—This paper introduces application of multi degree of freedom fuzzy(MDOFF) controller in permanent magnet (PM)drive system. The drive system model is developed for FO control. Simulation of the system is carried out to predict the performance at NL and under load,. The results indicate that application of MDOFF controller is effective for sensorless PM drive system.

Keywords—Sensorless FO controller, PM drives system, MDOFF controller.

I. INTRODUCTION

IN drive system which uses field orientation control technique, the system requires existence of speed/position and current sensors. Rotor speed and position are an essential component of any FOC system and can be determined via either measuring or estimation. Shaft encoder and position resolver have gained a wide spread attention to measure the motor speed and position of the rotor to obtain high accuracy. The presence of shaft sensor presents several effects on cost, reliability, drives size, and may spoils mechanical characteristic.

In sensorless systems, the rotor position can be estimated using the terminal voltage and the current through the motor phases [1-5]. The motor dynamic model in the state observer and measured motor terminal quantities make the observer able to estimate position and speed of the rotor[6-8]. Kalman Filter is an optimum state estimator. The filter's estimation is constantly corrected by an additional term originated from the measurement [9, 10]. The position information can be obtained using the Variation of the inductances L_d , and L_q for the interior permanent magnet motor type [11-13]. Air gap flux sensing methods were also proposed first for induction machines, then adopted to be used for PMSM [14, 15].

This research will present an advanced control technique (multi degree of freedom fuzzy control) for PM machine using FO approach. Mathematical model of the machine will be derived to deuce the control model required using CRPWM inverter with FO. Simulation of the drive system will be carried out to select the most suitable controllers for high performance PM drive system.

II. MOTOR MODEL

The Motor model used in the drive system simulation is deduced in this section as follows:

Faeka M. H. Khater is with Electronics Research Institute, Cairo, Egypt (phone: 202-331-0554, e-mail: khater@eri.sci.eg).

Mohamed I. Abu El- Sebah is with Electronics Research Institute, Cairo, Egypt (phone: 202-331-0552).

Farouk I. Ahmed is with Cairo University, Giza, Egypt (phone: 202-573-8579).

$$\bar{v}_s = R_s \bar{i}_s + \frac{d}{dt} \bar{\lambda}_s \quad (1)$$

Where

$$\frac{d}{dt}(\gamma + \alpha) = \omega_r, \quad \frac{d}{dt}\alpha = \omega_a - \omega_r, \quad \frac{d}{dt}\gamma = \omega_a \quad (2)$$

Referred to arbitrary reference frame

$$v_s^s e^{j(\gamma+\alpha)} = R_s i_s^s e^{j(\gamma+\alpha)} + \frac{d}{dt} [\lambda_{af} e^{j(\gamma+\alpha)} + L_s i_s^s e^{j(\gamma+\alpha)}] \quad (3)$$

$$v_s = R_s i_s + j\omega_a [\lambda_{af} + L_s i_s] + \left[\frac{d}{dt} \lambda_{af} + \frac{d}{dt} L_s i_s \right] \quad (4)$$

The matrix equation represents the PMSM model is developed to operate in the rotating reference frame ($\omega_a = P\omega_r$) [16].

$$P \begin{bmatrix} i_{sd} \\ i_{sq} \end{bmatrix} = \begin{bmatrix} \frac{R_s}{L_d} & -P\omega_r \\ P\omega_r & \frac{R_s}{L_q} \end{bmatrix} \begin{bmatrix} i_{sd} \\ i_{sq} \end{bmatrix} + \begin{bmatrix} \frac{1}{L_d} & 0 \\ 0 & \frac{1}{L_q} \end{bmatrix} \begin{bmatrix} v_{sd} \\ v_{sq} \end{bmatrix} + \begin{bmatrix} \frac{1}{L_d} & 0 \\ 0 & \frac{1}{L_q} \end{bmatrix} \begin{bmatrix} 0 \\ P\omega_r \lambda_{af} \end{bmatrix} \quad (5)$$

The mechanical torque equations are expressed as the following

$$T = \frac{3P}{2} (i_{sq} i_{sd} (L_d - L_q) + \lambda_{af} i_{sq}) \quad (6)$$

$$T = J \frac{d}{dt} \frac{\omega_e}{p} + B \frac{\omega_e}{p} + T_l \quad (7)$$

III. PROPOSED FUZZY CONTROLLER

The proposed fuzzy controller is a multi degree of freedom fuzzy (MDOFF) controller that depends on constructing two controllers; the first controller is designed for wide range of error, while the other is designed for

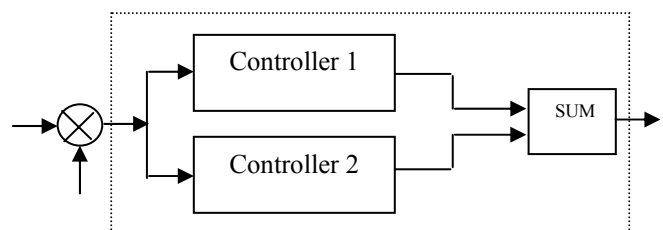

Fig. 1 Block diagram of the MDOFF Controller

fine-tuning [17]. Many researches used the above controllers as a two-degree of freedom controller each controller is fired in certain range. The used MDOFF controller presents another method to utilize the two controllers compound at each value of controller input with different weights depending on the error to produce the multi degree of freedom controller as shown in Fig.1.

IV. THE SPEED SENSORLESS METHOD

A new method for rotor position detection and speed estimation of permanent magnet synchronous machines has been presented in [18]. Information is obtained by monitoring controller signals to eliminate position and speed sensors. The method can reduce the system cost and improve the drive system reliability.

Such position detection and speed estimation method depends on the output control signal and the structure of the system controller without measurement. The rotor position can be detected from the waveform of the resultant emf via detection of zero crossing of the fundamental component. Fundamental component is obtained by using digital filters for the output control signals. In addition the speed estimation depends on the distance between each two zero crossing. Forming multi-waveform of resultant emf in 2 phase coordinates and 3-phase coordinates increase the position detection resolution. The rotor position detection technique intends to simplify the hardware and software due to reduction of the steps in axis transformation and speed estimation.

V. PROGRAM BLOCK DIAGRAM AND FLOWCHART

Controller program is developed to study system performance using MDOFF controller. A block diagram for the drive system is implemented for the purpose of performance prediction of the system. Fig. 2 shows the

Sensorless PM drive system with MDOFF controller. The flowchart of the program is illustrated in Fig. 3.

The algorithm of the fuzzy logic controller (FLC) is executed off line at the start of the program. The inputs to the FLC are the error & change of error. Activation of FLC is carried out with the help of membership functions and scaling factors to produce the controller output that can be used as reference for the current loop. Values of input and output of FLC are utilized to construct a look up table for using through the on-line control program. Figure 3-a shows the flowchart of the off line routine using FLC. The on line routine is illustrated in Fig. 3-b which optimizes the controller execution time compared with traditional technique.

VI. SIMULATION RESULTS

To predict the drive system performance at different load conditions, the PM drive system block diagram shown in Fig. 2 is used. Proposed speed algorithm is considered with MDOFF controller. Simulation results are presented in the following. The operation is related to the drive system without speed sensor, at no load and at load condition. The results deal with the drive system performance under condition of start up, speed changing, and a speed reversal. Each figure contains a different output of the drive system response such as actual speed, estimated speed, torque, phase current, and the current components in the RRF.

Figure 4 Shows the response for a start up at no load condition and followed by sudden speed change. Figure 5 Illustrates shows the drive system response under load condition for startup and speed reversal. The results show reasonable response in the speed reversible performance at sudden change in speed which confirms the effectiveness of the controller to avoid large overshoots.

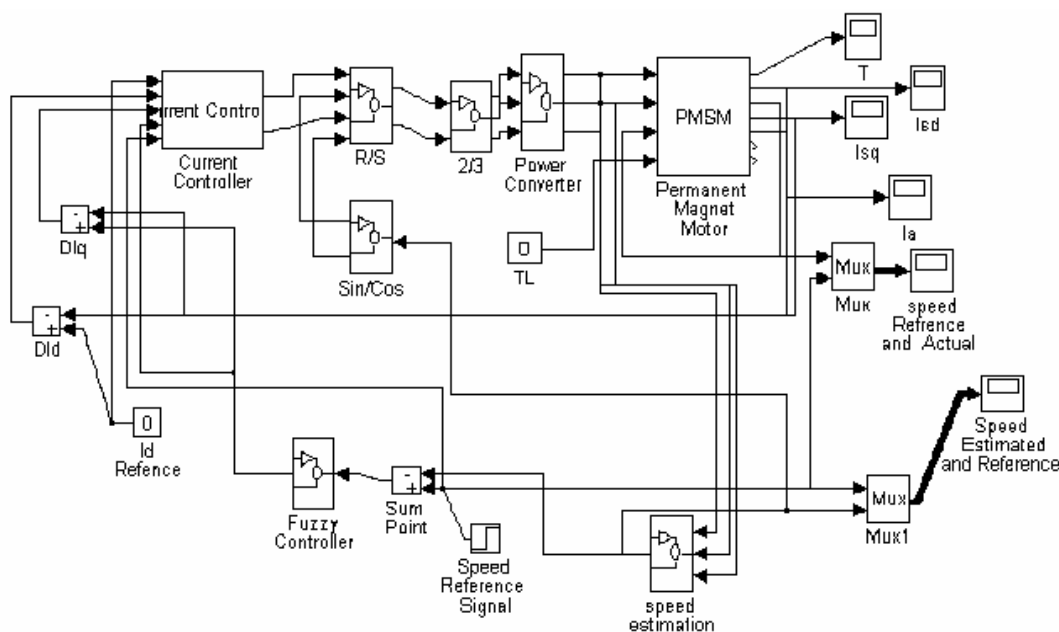

Fig. 2 The drive system with MDOFF controller and based on speed estimation

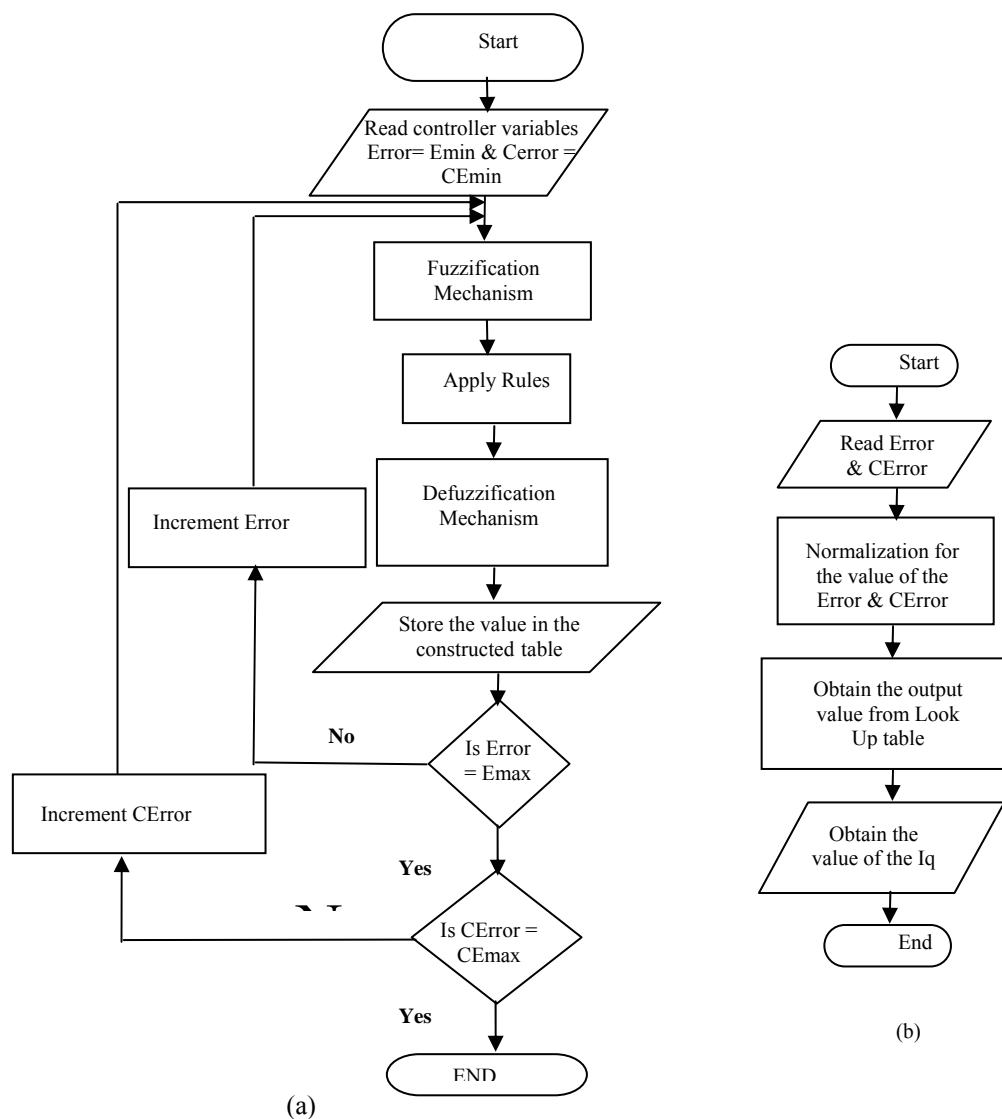

Fig. 3 Speed fuzzy controller flowchart

VII. CONCLUSION

This work presents utilization of new MDOFF controller in sensorless PM motor. The drive system model has been developed for simulation and performance prediction at no load and under load. The results of modeling and simulation indicate that MDOFF controller is effective and adequate for sensorless PM drive system.

REFERENCES

- [1] Erdman, D.M., Harms, H. B., and Oldenkamp, J. L., "Electronically commutated DC Motors for the appliance industry", IEEE IAS Conf. Rec. Oct. 1984, pp.1339-1345.
- [2] Davoine, J., Parret, R., and Le-huy, H., "Operation of a self controlled synchronous motor without a shaft position sensor," IEEE Trans. Ind. App., vol. IA-19, No. 2, Mar./Apr. 1983, pp 217-222.
- [3] Wu, R., and Slemon, G.R., "A permanent magnet motor drive without a shaft sensor," IEEE Trans. Industry Applications, Vol. 27, No. 5, Sept./Oct. 1991, pp. 1005-1011.
- [4] Gopakumar, K., Ranganathan, V. T., and Bhat, S.R., "Vector Control of Induction Motor with Split Phase Stator Windings," IEEE-IAS Conf. Proceedings, 1994, pp. 569-574.
- [5] Kim, J.S., and Sul, S., "High performance PMSM drives without rotational position sensors using reduced order observer," IEEE-IAS Conf. Rec., 1995, pp. 75-82.
- [6] Jones, L.A. and Lang, J.H., "A state observer for the permanent magnet synchronous motor," IEEE Trans. Ind. Elect., vol 36, No. 3, August 1989, pp. 374-382.
- [7] Moynihan, J.F., Egan, M. G., and Murphy, J.M.D., "The application of state observers in current regulated PM synchronous drives," IEEE IECON Proceedings, 1994, pp. 20-25.
- [8] Consoli, A., Musumeci, S., Raciti, A., and Tesla, A., "Sensorless Vector and Speed Control of Brushless Motor Drives," IEEE Trans. Ind. Elect., Vol. IA-41, No. 1, Feb. 1994, pp. 91-96.
- [9] Dhaouadi, R., Mohan, N., and Norum, I., "Design and implementation of an extended Kalman filter for state estimation of a Permanent Magnet Synchronous Motor," IEEE Trans. Power Elect., July 1991, pp. 491-497.
- [10] Schroedl, M., "Sensorless Control of Permanent Magnet Synchronous Motors," Electric Machines and Power Systems, Vol. 22, 1994, pp. 173-185.
- [11] Binns, K. J., Shimmin, D. W., and Al-Aubidi, K.M., "Implicit Rotor Position sensing using motor winding for a self commutation Permanent Magnet Drive system," IEE Proc., Part b, Vol. 138, No. 1, Jan. 1991, pp. 28-34.
- [12] Kulkarni, A.B., and Ehsani, M., "A Novel Position sensor Elimination Technique for the Interior Permanent Magnet Synchronous Motor Drive," IEEE Trans. Ind. App., Vol. 28, No. 1, Jan/Feb. 1992, pp. 144-150.
- [13] Masaki, R., Kaneko, S., Hombu, M., Sawada, T., and Yoshihara, S., "Development of a position sensorless control system on an electric vehicle driven by a permanent magnet synchronous motor"

Power Conversion Conference, 2002. PCC-Osaka 2002. vol. 2, 2002, pp. 571 -576.

- [14] Lipo , T.A. and Chang , K.C., "A new Approach to Flux and Torque Sensing in Induction Machines", IEEE Trans. on Industrial Applications, vol. IA-22, July/Aug. 1986, pp. 731-737.
[15] DeDoncker , R.W., and Profumo , F., "The Universal Field Oriented Controller Applied to Tapped Stator Windings Induction Motors", IEEE-PESC 20th Ann. Mtg., 1989, pp. 1031-1036.

- [16] Abu-Elsebah , M.I "Sensorless Advanced Control of Permanent Magnet Drive System ". PhD Thesis, Cairo University, 2003.
[17] Khater , F.M.H., Ahmed , F.I., and Abu-Elsebah , M.I., "Multi Degree of Freedom Fuzzy Controller," 2003 IEEE International Symposium on Intelligent Control, Oct. 5-8,2003 houston, Texas, USA.
[18] Khater , F.M.H., Ahmed , F.I., and Abu-Elsebah , M.I., "Detection of Rotor Position of Permanent Magnet Synchronous Motor," Proc.of SICE'2001, July 25th-27th, Nagoya, Japan, 2001, pp. 765-769.

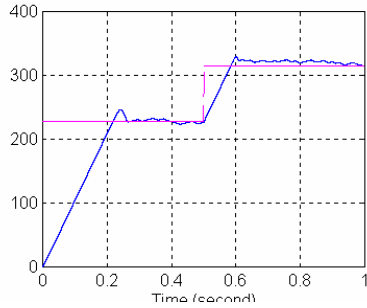

The actual motor speed

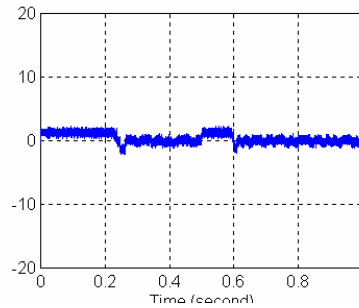

The electric torque

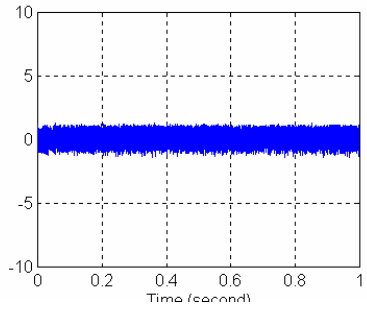

The direct current component

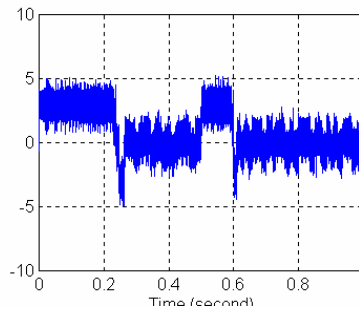

The quadrature current component

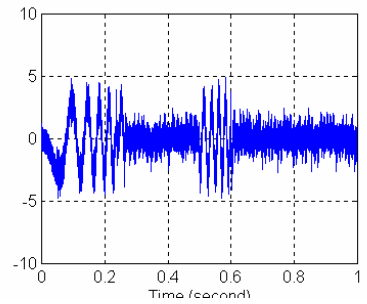

The phase current

Fig. 4 Drive system response under speed changing using proposed sensorless algorithm at no load

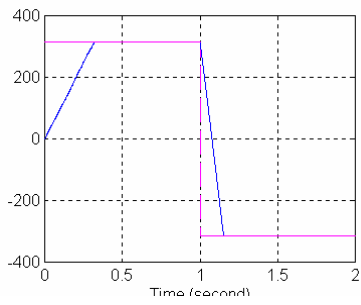

The actual motor speed

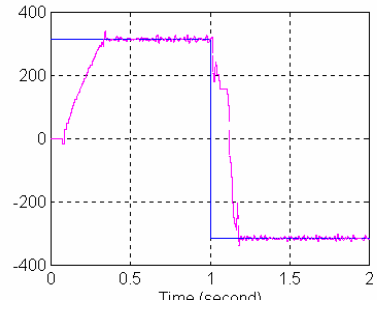

The estimated motor speed

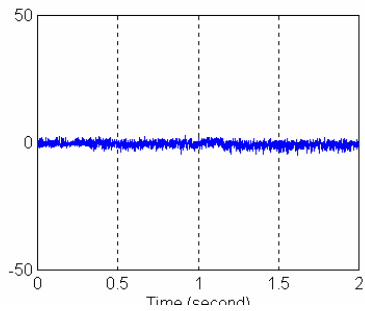

The direct current component

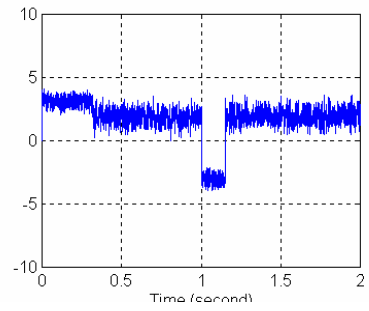

The electric torque

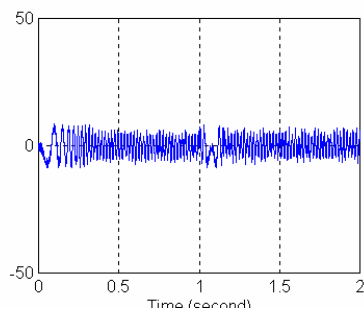

The Phase Current

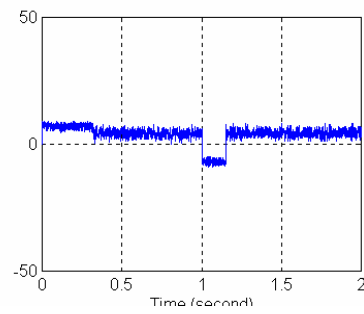

The quadrature current component

Fig. 5 Speed reversal with proposed speed sensorless algorithm under load