

Development of a Portable Welding Robot with EtherCAT Interface

Juyi Park, Sang-Bum Lee, Jin-Wook Kim, Ji-Yoon Kim, Jung-Min Kim, Hee-Hwan Park, Jae-Won Seo, Gye-Hyung Kang, and Soo-Ho Kim

Abstract—This paper presents a portable robot that is to use for welding process in shipbuilding yard. It has six degree of freedom and 3kg payload capability. Its weight is 21.5kg so that human workers can carry it to the work place. Its body mainly made of magnesium alloy and aluminum alloy for few parts that require high strength. Since the distance between robot and controller should be 50m at most, the robot controller controls the robot through EtherCAT. RTX and KPA are used for real time EtherCAT control on Windows XP. The performance of the developed robot was satisfactory, in welding of U type cell in shipbuilding yard.

Keywords—Portable welding robot, Shipbuilding, EtherCAT

I. INTRODUCTION

AUTOMATION in ship-building yard possessed many difficulties. Among such difficulties, this paper is focused on portability problem. Since the most work-pieces in shipbuilding yard are very huge, they cannot be moved to the fabricating devices. Instead, the devices should be placed near the work-pieces through many obstacles such as access holes and fences. Moreover, the cables for power and control are relatively long and they cause other difficulties in handling devices.

In such environment, portable welding carriages are widely used because they are very compact, light and effective for simple tasks. So, huge number of welding carriages is used in shipbuilding yard for relatively simple welding tasks such as straight line weld. In the meanwhile, since one type of carriage can perform only a specific task, few types of carriage should be work together when a work cell consists of different tasks. For example, a U-cell consists of horizontal strait line welding and vertical weaving welding and workers use two types of carriages: horizontal carriage and vertical weaver. It induces increased working time owing to the setting of the devices. Moreover these carriages have another weakness. They cannot weld at the starting and finishing edge areas of about 100mm respectively due to the lack of welding-torch angle control mechanism.

This work therefore developed a portable robot that can perform various welding tasks in a work cell. Once worker sets the robot in a cell it performs all required welding job. Worker therefore can do another task after setting the robot.

In order to realize light weighted portable robot authors employed magnesium alloy as a main material for robot body

J. Park *et al.* are with the Daewoo Shipbuilding and Marine Engineering Co. Ltd., Seoul Korea (phone: 822-3667-3813, fax: 822-3667-3819; e-mail: juyipark@dsme.co.kr).

and EtherCAT technology in control architecture. Magnesium alloy is used to minimize the body weight of the robot that has 6 degree of freedom and 3kg payload ability. Since the magnesium alloy is relatively weak than aluminum alloy, some critical parts are made of aluminum alloy.

EtherCAT[1] is employed to device the robot and controller over long cable. Since the distance between controller and robot should be 50m, a reliable communication is necessary for this connection. So, EtherCAT is selected because its reliability and real-time performance are well proven in many applications [2,3]. Moreover, since it uses conventional Ethernet port and does not require additional hardware, it helps to implement relatively simple hardware.

Control program is written on Window XP. RTX [4] from IntervalZero is added to realize real time control on Windows XP and KPA EtherCAT master [5] from Coenig is used for EtherCAT communication.

The developed robot is tested in a block building shop of shipbuilding yard for welding task of U-type cell. Robot operator places the robot at the front of the U-cell on the guide line of laser strip. Offline program (OLP) module then generates robot job program automatically based on the shape and size of the cell. The robot finds exact welding position with a touch sensor and performs welding according to the robot job program.

This paper organized as follows: Section 2 presents the requirements and development strategy of portable welding robot and section 3 presents the hardware and software of the robot. Application example and results are presented in section 4 and conclusions follow.

II. REQUIREMENTS AND STRATEGY

A. Requirements

The developed robot must be light enough that a worker can carry it over cross-bars and access-holes of ship blocks. The target weight of the robot is 20kg, which is the recommended maximum payload of human workers.

The target payload of the robot is 3kg. Since the weight of welding torch and cable is 1.5 kg and various sensors will be added on the tip, payload 3kg is minimum specification of the robot.

The required working width is 900mm and height 800mm. The working depth is related to the robot location from the work piece and it is decided to be 600mm.

As basic functions, the robot must have electric break for safety and absolute encoder for fast boot up.

B. Development Strategy

Magnesium alloy is selected as main material for the robot body because it is lighter than aluminum alloy that is very popular material for robot body. Most parts are fabricated using magnesium except some shaft which should have high strength.

EtherCAT is an important communication method in this system. Since the robot controller and robot are connected through 50m long cable. The connection must be very reliable and the cable should not be too thick for easy handling. So EtherCAT is employed for the connection, because its performance and reliability are well proven from many applications and it requires only one LAN cable for connection. Therefore servo drives are installed near motors in robot body and they communicate with main controller through EtherCAT.

Table I shows the specifications designed according to the requirements above.

TABLE I
 SPECIFICATION OF PORTABLE WELDING ROBOT

Item	Specification
Robot weight	20 kg
Payload	3 kg
Working radius	794mm
Accuracy of repetitions	+/- 0.1 mm
Freedom	6 rotating joints
Position sensor	Absolute encoder
Actuator	AC servo motor

III. DEVELOPMENT

A. Robot Body

Magnesium alloy, AZ31 [7], is main material of the robot. Its density is 1.7 g/cm³ and it is lighter than aluminum alloy, A6061, of which density is 2.7 g/cm³. The strength and other properties are listed in following table. As shown in the table, the strength of magnesium alloy is lower than aluminum alloy. Aluminum alloy therefore is used for some critical part that has to be strong.

TABLE II
 MECHANICAL PROPERTIES OF MAGNESIUM AND ALUMINUM ALLOY

Property	Unit	Magnesium Alloy, AZ31	Aluminum Alloy, 6061
Tensile strength	Mpa	255	310
Yield strength	Mpa	200	276
Elongation	%	12	12
Young's modulus	Gpa	45	68.3
Hardness	HB	49	95

Motors in the robot are AC servo motors from Tamagawa: model 4601, 4602 and 4603. They all have electric brakes and absolute encoders, their capacities are 30w, 50w and 100w, respectively. As transmissions, Harmonic drives are used with timing belt. The resultant reduction ratios are 120, 451, 353, 100, 100 and 90, respectively.

Fig. 1 and 2 shows the schematic of the robot body. The link length are designed based on the required work space and verified through series of simulation using ROBCAD. Three magnets are placed bottom of the robot to support the robot

during motion. Handles are also attached to the body for it is a portable robot.

Resultant weight of robot body is 21.9 kg without tool. It is heavier by 1.9kg than desired weight. It is mainly caused to the thick forearm, which is originally designed very thin but was reinforced after finishing welding test.

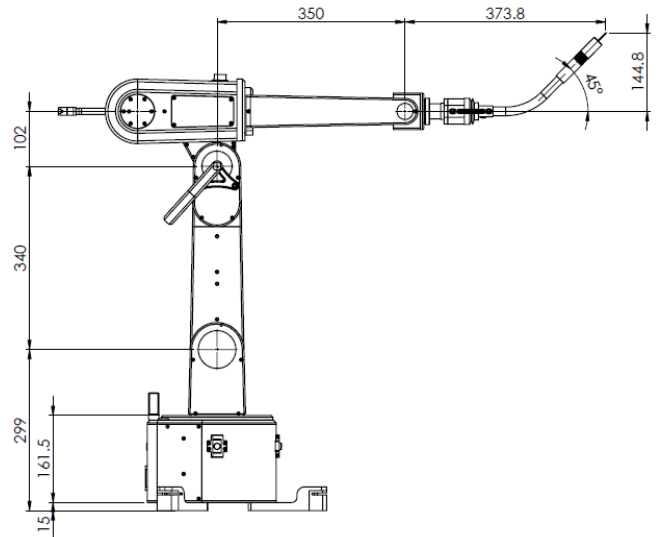

Fig. 1 Schematic of robot

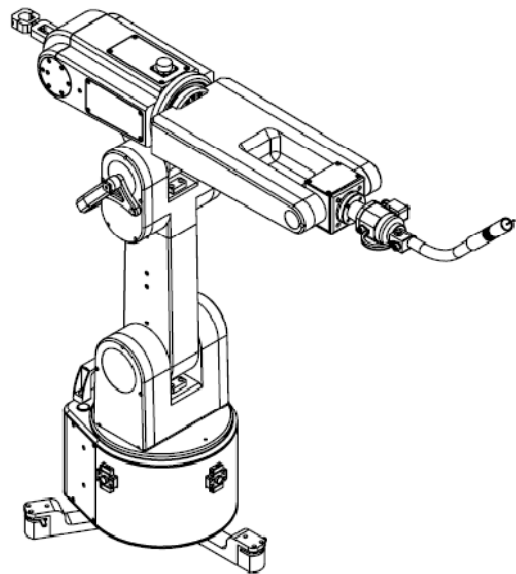

Fig. 2 Robot body

B. Robot Controller hardware

Robot is in ship-block while its controller is located out of the block, beside the wall of shop. They are connected through one long cable which contains power, communication and I/O signal lines. Four power lines transmit DC 24V 50A and DC12V 5A. Four communication lines are used for EtherCAT and another four lines for Ethernet. Six I/O lines are for emergency stop switches and power control switch. Beside the

robot control cable there is all-in-one welding cable which contains welding plus line, welder control lines and gas hose. The block diagram in Fig.3 shows the hardware structure of the robot controller.

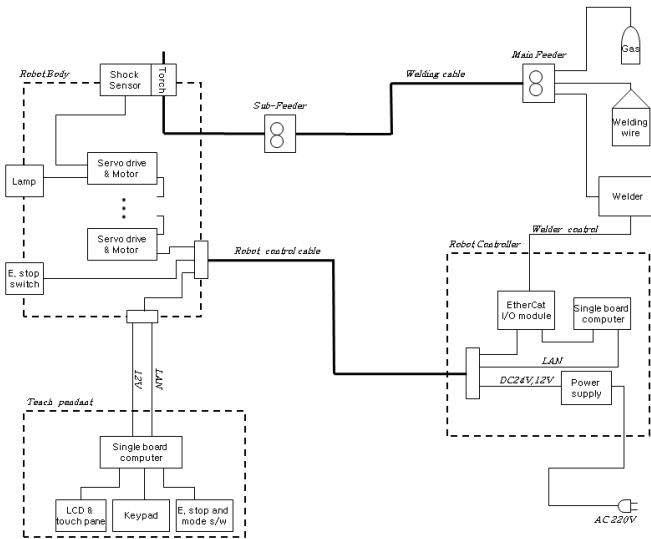

Fig. 3 Block diagram of robot controller

In the developed controller EtherCAT is employed because it is the well proven technology over many applications, and the control hardware's structure can be very simple. Since EtherCAT enables real-time control through Ethernet port of common PC board, it can be easily implemented on common single board computer.

Control hardware consists of single board computer, power supply and I/O modules. Detailed specifications are shown in following table.

TABLE III
 SPECIFICATION OF CONTROL HARDWARE

Part	Specification
Single board computer	Intel core 2 Due E5400
Lan card	Intel PRO100
Power supplies	Motor power: 24V, 1500W TP power: 12V, 60W ATX Power: 12V, 400W
I/O Module	EtherCAT bus coupler DIN 8ch. NPN type DOUT 8ch. NPN type D/A 2ch, +/- 10V A/D 2ch, +/- 10V

Servo drive is AEM of Copley Controls [6]. It supports AC servo motor control with CAN over EtherCAT (COE) and absolute encoder interface including SSI, EnDat and Absolute A. There are two kind of I/O method in controller. One is to use EtherCAT I/O module and other is to use I/O pin of servo drive. The former is used for welder interface and emergency stop switches and the latter for motor brake, status lamp and sensor input.

C. Robot Controller Software

Control program is developed under Window XP. RTX is added to enhance the real-time control performance and KPA EtherCAT master is used for servo communication.

Robot control program consists of three processes as illustrated in Fig. 4. Processes communicate each other through shared memory and message passing. The communication includes data transfer and synchronization. Since the most critical part in robot controller is real-time motion control performance, Task Executor (TE) and Servo process run under RTX. Motion control thread in Servo process runs at 1kHz and sends motion command to servo drive over EtherCAT. It also sends synchronization message to I/O thread at 1kHz. I/O thread sends synchronization message to interpolation thread in TE at 16kHz.

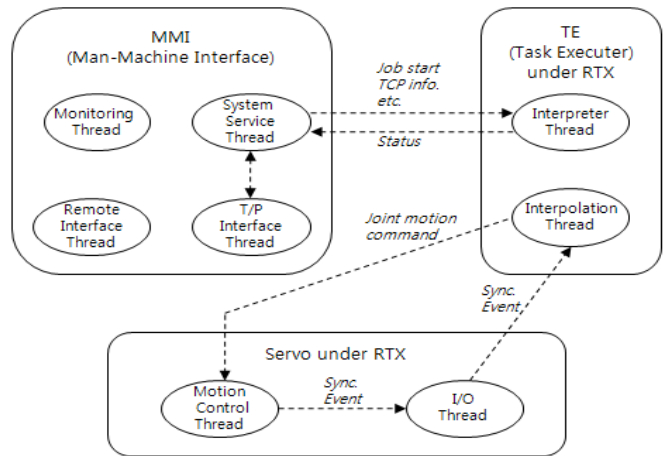

Fig. 4 Processes and threads in robot controller

In servo driver, the motion command from robot controller is processed in cyclic synchronous position (CSP) mode, one of CAN protocol. There were two position control mode in CAN protocol, CSP and interpolated position (IP) mode. The position command, in CSP mode, is directly sent to the position controller of servo drive, whereas motion command accumulated in buffer in IP mode. Authors selected CSP mode because it brought better performance than IP. See Fig. 5 for block diagram of CSP mode.

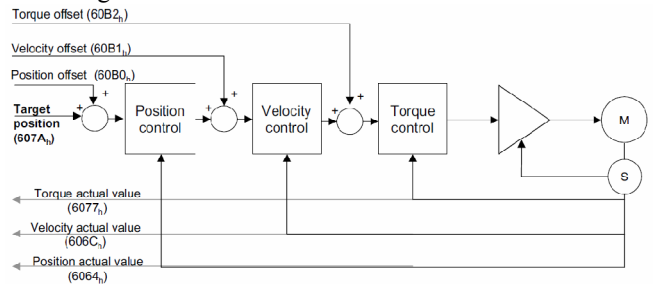

Fig. 5 Cyclic synchronous position (CSP) mode

D. Teach Pendant (TP)

Teach pendant (TP) is programmed based on Windows XP in single board computer. Following is the specification of the hardware for TP.

TABLE IV
SPECIFICATION OF TEACH PENDANT

Part	Specification
Processor	Intel Atom N270 1.6GHz
Memory	DDR II 1G
HDD	CF type II 16G
Display	7" wide WVGA touch screen
Key-pad	24 key, Metal-Dom switch
Switch	E. stop, Mode, Enable
Power	DC 12V, 23W
Battery	Lithium polymer, 1000mAh
O/S	Windows XP

CPU board is an off-the-self commercial board and Keypad interface board is implemented using PIC16F877. Fig. 6 and 7 shows the block diagram of teach pendant hardware and GUI on TP screen, respectively. TP is connected to the robot controller through Ethernet with TCP/IP protocol.

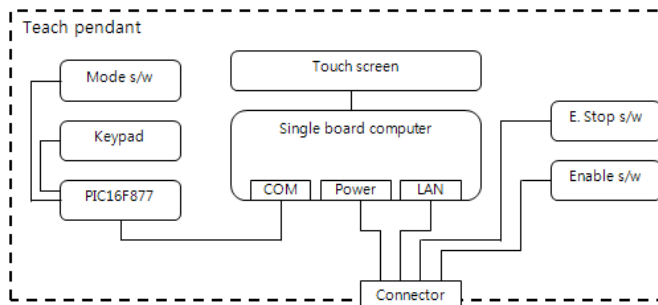

Fig. 6 Block diagram of Teach pendant

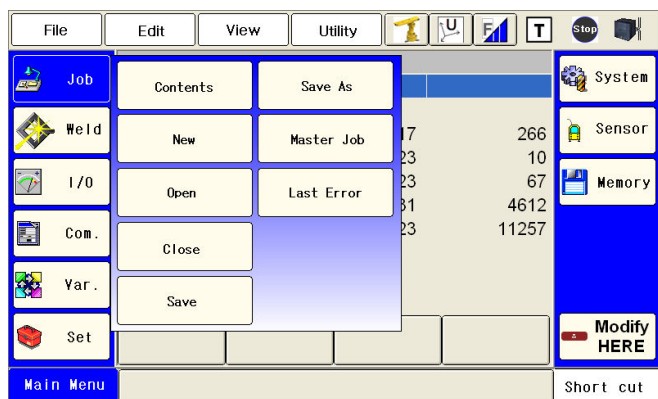

Fig. 7 GUI of Teach Pendant

IV. APPLICATION

First target of this robot is welding task of U type cell (U-cell) that consists of horizontal line and vertical weaving welding tasks as shown in Fig. 8. Since there are plenty of U-cells in ship blocks, authors selected this application.

An off-line program (OLP) module is developed to cover various size and shape of U-cell. The shape of U-cell is depending on the location of scallop hole and collar plate. Once worker selects proper shape from OLP UI and input approximated dimension, OLP generate a job file which is a series of robot command to perform full welding tasks of the U cell.

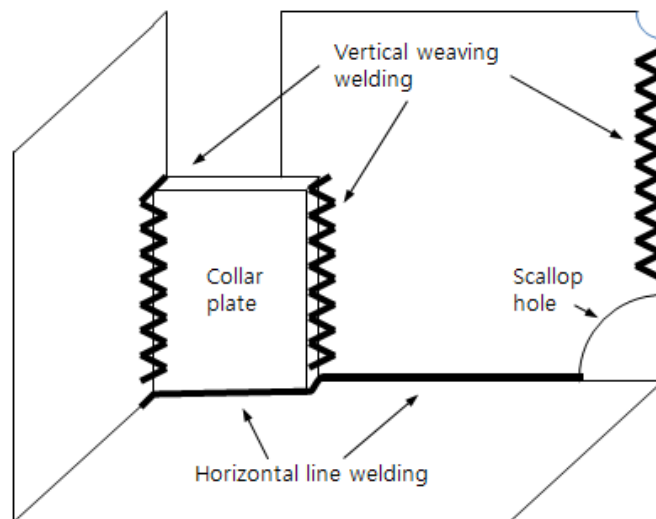

Fig. 8 Typical U-cell welding task

The location of robot in U-cell is not known exactly because the robot is manually placed by hands. And the dimension of the work-piece may not be correct because they are manually fabricated in the previous process – such dimension error is usually neglected in shipbuilding yard. So, line laser and touch sensors are installed to compensate such error. The robot has line laser diode at the front and right sides of its base, in order to let workers place the robot at the right position. When worker sets the robot, he or she has to adjust the robot position so that the laser lines meet the cross line of front and right side of the U-cell.

Touch sensor helps the robot find the correct welding points. The principle of touch sensor is very simple. DC plus line is connected to the welding torch and minus to the work-piece. Controller checks if the torch touched the work-piece while the torch moves to the work-piece. As a result, this sensor can be used to find the correct location of work-pieces.

Fig. 9 and 10 shows the real pictures taken while operator handle and execute the robot for welding job. In conventional task, workers use two different types of welding carriages for this task: normal linear weaving carriage for horizontal welding and so-called vertical weaver for vertical welding. In addition, worker should perform manual welding for edge parts of the U-cell because there remains un-welded region of welding carriage. So, workers must install carriages three or four times depending on the shape and do manual welding in conventional U-cell welding. On the contrary, workers do only one setting for the portable welding robot without manual welding. As a result, the robot reduced the time and effort of workers.

In the meanwhile, there are few shortcomings of the developed robot. It is still heavy to carry. The weight of the robot body is 21.9kg and welding torch with a shock sensor and cable weighs 3.8kg. Since the worker must move the robot body, torch and cable together, he or she has to move 25.7kg at once. It has to be reduced more for better portability. High price of the robot is another shortcoming which mainly caused by use of magnesium alloy. The price can be reduced when it is massively produced.

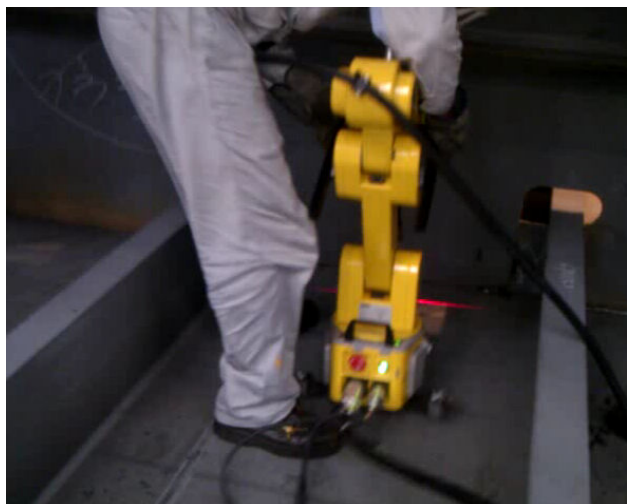

Fig. 9 Handling and setting of the developed robot

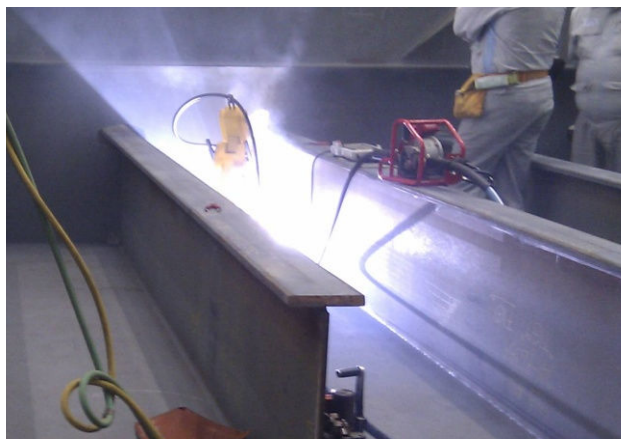

Fig. 10 Welding job by the developed robot

- [7] Y. Estrin *et al.*, "Microstructure, texture and mechanical properties of the magnesium alloy AZ31 processed by ECAP," *Int. J. Materials Research*, Jan. 2008, pp. 50-55.

V. SUMMARY

A portable welding robot is developed in this work. It was successfully applied in ship block production shop to perform welding tasks in U type cells. Operators could generate welding job programs for given U-cells through an OLP module, and the robot performed welding task after correcting the position and dimension error with a touch sensor.

Although it has few weaknesses such as relatively heavy weight and high manufacturing price, it was very effective and useful in ship building yard. The weight and the price of the robot will be reduced in the next version of the portable robot.

REFERENCES

- [1] EtherCAT technology group, "EtherCAT The Ethernet Fieldbus", <http://www.ethercat.org>.
- [2] S.G. Robertz *et al.*, "Industrial robot motion control with real-time Java and EtherCAT," *IEEE Conf. Emerging Technologies and Factory Automation*, 2007, pp. 1453-1456.
- [3] Y. Moon *et al.*, "A study on Development of Soft-Motor Controller using EtherCAT," *Journal of Korean institute of intelligent systems*, 2007, Vol. 17, No. 6, pp. 826-831.
- [4] IntervalZero website. <https://www.intervalzero.com>
- [5] Koenig website. <https://koenig-pa.com>
- [6] Copley Controls, "Manual: Accelnet Plus Module EtherCAT AEM" <http://www.copleycontrols.com/Motion/pdf/AEM-ds.pdf>