

Implementation of Second Order Current-Mode Quadrature Sinusoidal Oscillator with Current Controllability

Koson Pitaksuttayaprot and Winai Jaikla

Abstract—The realization of current-mode quadrature oscillators using current controlled current conveyor transconductance amplifiers (CCCCTAs) and grounded capacitors is presented. The proposed oscillators can provide 2 sinusoidal output currents with 90° phase difference. It is enabled non-interactive dual-current control for both the condition of oscillation and the frequency of oscillation. High output impedances of the configurations enable the circuit to be cascaded without additional current buffers. The use of only grounded capacitors is ideal for integration. The circuit performances are depicted through PSpice simulations, they show good agreement to theoretical anticipation.

Keywords—Current-mode, Oscillator, Integrated circuit, CCCCTA.

I. INTRODUCTION

THE controlled quadrature oscillators (QO) are extremely useful circuits for various communication applications, wherein there is a requirement of multiple sinusoids which are 90° phase shifted, e.g. in quadrature mixers and single-sideband modulators [1]. Recently, current-mode circuits have been receiving considerable attention due to their potential advantages such as inherently wide bandwidth, higher slew-rate, greater linearity, wider dynamic range, simple circuitry and low power consumption [2-3].

Recently, the attention has turned to use of the new active building block, namely current conveyor transconductance amplifier (CCTA) [4] as voltage and current-mode active element since it has been shown that the CCTA seems to be a versatile component in the realization of a class of analog signal processing circuits, especially analogue frequency filters. In addition, output current of CCTA can be electronically adjusted. Besides, the modified version of CCTA which the parasitic resistance at current input port can be electronically controlled has been proposed in [5]. This CCTA is called current controlled current conveyor transconductance amplifier (CCCCTA).

From literature survey, it is found that several implementations of oscillator employing CCCCTAs have been

reported [6-12]. Unfortunately, these reported circuits suffer from one or more of following weaknesses:

- Non-interactive dual current control for CO and FO [6, 7, 8, 9, 10, 11]
- Non-availability of quadrature explicit-current-outputs from high-output impedance terminals [6, 10]
- Requirement of plus and minus type of active element which the number of transistor used for realizing the active component is more than the standard one [7, 8, 9, 11, 12].

The aim of this paper is to introduce a high output impedance current-mode quadrature oscillator, based on CCCCTAs. The condition of oscillation (CO) and frequency of oscillation (FO) can be independently adjusted by electronic method. The circuit construction consists of 2 CCCCTAs and 2 grounded capacitors. The PSPICE simulation results are also shown, which are in correspondence with the theoretical analysis.

II. THEORY AND PRINCIPLE

A. Basic Concept of CCCCTA

The principle of the CCCCTA was published in 2008 by S. Siripruchyanun and W. Jaikla [5]. The schematic symbol and the ideal behavioral model of the CCCCTA are shown in Fig. 1(a) and (b). The characteristics of the ideal CCCCTA are represented by the following hybrid matrix:

$$\begin{bmatrix} I_y \\ V_x \\ I_{z,zc} \\ I_o \end{bmatrix} = \begin{bmatrix} 0 & 0 & 0 & 0 \\ R_x & 1 & 0 & 0 \\ 1 & 0 & 0 & 0 \\ 0 & 0 \pm g_m & 0 & 0 \end{bmatrix} \begin{bmatrix} I_x \\ V_y \\ V_z \\ V_o \end{bmatrix} \quad (1)$$

If the CCCCTA is realized using BJT technology, R_x and g_m can be respectively written as

$$R_x = \frac{V_T}{2I_{B1}}, \quad (2)$$

and

$$g_m = \frac{I_{B2}}{2V_T}. \quad (3)$$

W. Jaikla is with the Department of Engineering Education, Faculty of Industrial Education, King Mongkut's Institute of Technology Ladkrabag, Bangkok, 10520, Thailand (e-mail: winai.ja@hotmail.com).

K. Pitaksuttayaprot is with the Electronics Computer Program, Faculty of Industrial Technology, Phetchabun Rajabhat University, Phetchabun, 67000, Thailand (e-mail: kosonpit@hotmail.com).

V_T is the thermal voltage. I_{B1} and I_{B2} are the bias currents used to control the parasitic resistance and transconductance, respectively.

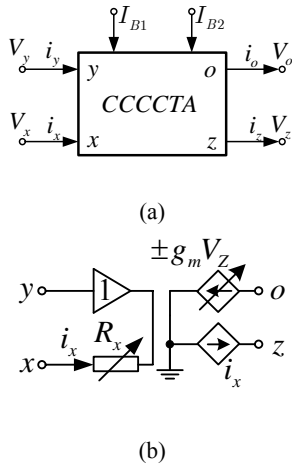

Fig. 1 CCCCTA (a) Symbol (b) Equivalent circuit

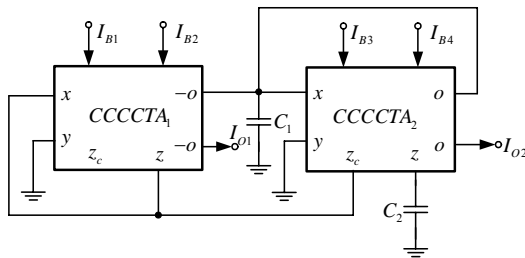

Fig. 2 Presented current-mode quadrature oscillator

B. Proposed Current-Mode Quadrature Oscillator

The proposed current-mode oscillator is illustrated in Fig. 2. It consists of 2 CCCCTAs and 2 grounded capacitor. It should be noted that output impedances of two output currents (I_{o1} and I_{o2}) are high impedance which can be directly drive load without additional current buffer. Considering the circuit in Fig. 2 and using CCCCTA properties in section II.B, the characteristic equation of the proposed oscillator can be written as

$$s^2 C_1 C_2 R_{x2} + s C_2 \left(1 - \frac{g_{m1} R_{x1}}{2} \right) + g_{m2} = 0 \quad (4)$$

From Eq. (4) the frequency of oscillation (FO) and the condition of oscillation (CO) can be computed as follows:

$$\omega_{osc} = \sqrt{\frac{g_{m2}}{C_1 C_2 R_{x2}}} \quad (5)$$

and

$$1 = \frac{g_{m1} R_{x1}}{2} \quad (6)$$

If R_x and g_m are respectively equal to Eq. (2) and (3), the FO and CO can be re-expressed to be

$$\omega_{osc} = \frac{1}{V_T} \sqrt{\frac{I_{B3} I_{B4}}{C_1 C_2}}, \quad (7)$$

and

$$8I_{B1} = I_{B2}. \quad (8)$$

It is apparent from Eqs. (7) and (8) that FO and CO are non-interactive. The FO could be electronically controlled by I_{B1} and g_{m1} without affecting the CO. Also, the CO could be tuned electronically by I_{B3} and I_{B4} without affecting the FO. This tuning law is considered as advantage over the oscillators appeared in Ref. [12] which provide only orthogonal tune. Moreover, the proposed oscillator uses the same type of active element (without plus and minus ports) unlike the oscillator in Ref. [12].

The relation between two output currents at the oscillation frequency is

$$\frac{I_{o2}(s)}{I_{o1}(s)} = -\frac{2g_{m2}}{g_{m1} R_{x1} s C_2}. \quad (9)$$

It is evident from Eq. (9) that current output I_{o1} is phase-shifted by 90° from current output I_{o2} and thus the oscillator can be used quadrature oscillator.

C. Non-idea Case

In practice, the CCCCTA is possible to work with non-idealities. Its properties will change to,

$$V_x = I_x R_x + \beta V_y; I_z = \alpha I_x; I_o = \gamma g_m V_z; I_{zc} = \lambda I_z \quad (10)$$

where α and λ are the parasitic current transfer gains from x terminal to z terminal and z terminals to z_c terminal, respectively. β is the parasitic voltage transfer gain from y terminal to x. γ is the voltage transfer gain from z terminal to o terminal. Considering the current transfer gains, the modified current transfer function of Fig. 2 can be expressed as

$$s^2 C_1 C_2 R_{x2} + s C_2 \left(1 - \frac{\alpha_2 \lambda_2 \gamma_1 g_{m1} R_{x1}}{\alpha_1 + 1} \right) + \alpha_2 \gamma_2 g_{m2} = 0 \quad (11)$$

From Eq. (11), FO and CO of the proposed circuit are

$$\omega_{osc}^* = \sqrt{\frac{\alpha_2 \gamma_2 g_{m2}}{C_1 C_2 R_{x2}}} \quad (12)$$

and

$$1 = \gamma_1 \lambda_2 \alpha_2 \frac{g_{m1} R_{x1}}{\alpha_1 + 1} \quad (13)$$

III. RESULTS OF COMPUTER SIMULATION

The working of the proposed oscillator has been verified in PSpice simulation using the BJT implementation of the CCCCTA in Fig. 3. The PNP and NPN transistors employed in the proposed circuit were simulated by using the parameters of the PR200N and NR200N bipolar transistors of ALA400 transistor array from AT&T [13]. The circuit was biased with $\pm 2.5V$ supply voltages, $C_1=C_2=0.2nF$, $I_{B1}=I_{B3}=40\mu A$, $I_{B2}=315\mu A$ and $I_{B4}=150\mu A$. The simulated frequency is $f_{O}=2.11MHz$. Fig. 3 shows simulated quadrature output waveforms. The spectra of output currents are shown in Fig. 4. The THD is about 2.76%.

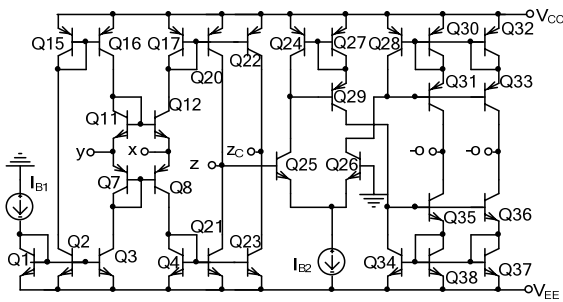

Fig. 3 Internal construction of the BJT CCCCTA

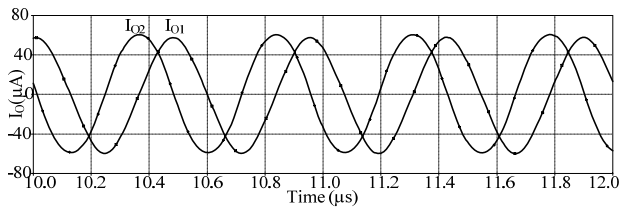

Fig. 4 The simulation result of quadrature outputs

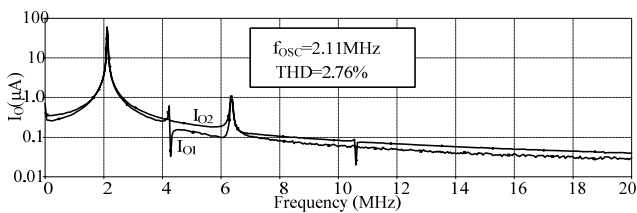

Fig. 5 Frequency spectrum of signal in Fig. 4

IV. CONCLUSION

The current-mode quadrature oscillator has been presented. The frequency of oscillation and condition of oscillation can be electronically adjusted with non-interactive dual-current control for both the condition of oscillation and the frequency of oscillation. The proposed oscillator consists of 2 CCCCTAs and 2 grounded capacitors without additional external

resistors, which is ideal for integrated circuit. PSPICE simulations are included to verify the theoretical analysis. Simulated and theoretical results are in close agreement.

REFERENCES

- [1] I. A. Khan and S. Khawaja, "An integrable gm-C quadrature oscillator," International Journal of Electronics, vol. 87, no. 1, pp. 1353-1357, 2000.
- [2] C. Toumazou, F. J. Lidger and D. G. Haigh, "Analogue IC design: the current-mode approach," Peter Peregrinus, London, 1990.
- [3] U. Cam, A. Toker, O. Cicekoglu and H. Kuntmam, "Current-mode high output-impedance sinusoidal oscillator configuration employing single FTFN," Analog Integrated Circuits and Signal Proc., vol. 24, pp. 231-238, 2000.
- [4] R. Prokop, V. Musil, "New modern circuit block CCTA and some its applications," The Fourteenth International Scientific and Applied Science Conference - Electronics ET'2005, Book 5. Sofia: TU Sofia, pp. 93-98, 2005.
- [5] M. Siripruchyanun and W. Jaikla, "Current controlled current conveyor transconductance amplifier (CCCTA): a building block for analog signal processing," Electrical Engineering, vol. 90, pp. 443-453, 2008.
- [6] T. Bumronghoke, W. Jaikla, M. Siripruchyanun, "An electronic controllable simple current-mode oscillator using single MO-CCCCTA and grounded capacitors," The 1st international conference on Technical Education: pp. 217-220, 2010.
- [7] S. Lawanwisut, M. Siripruchyanun, "High output-impedance current-mode third-order quadrature oscillator based on CCCCTAs, IEEE Tencon 2009, pp. 1-4, 2009.
- [8] N. Pisutthipong, P. Silapan, M. Siripruchyanun, "CC-CCTA based current-mode quadrature oscillator," The Seventh PSU Engineering Conference, 302-305, 2009.
- [9] P. Uttaphut, "New current-mode multiphase sinusoidal oscillators based on CCCCTA-based lossy integrators," Przeglad Elektrotechniczny (Electrical Review), vol. 8, pp. 138-141, 2011.
- [10] D. Pandey, L.K. Singh, "Realization and study of high performance voltage mode oscillator based on CCCCTA: a building block for analog signal processing," International Journal of Computer Science and Information Security, vol. 8, pp. 132-138, 2010.
- [11] S. Lawanwisut, M. Siripruchyanun, "An active-only high-output impedance current-mode quadrature oscillator using CCCCTA based-lossless differentiators," IEEE Tencon 2009, pp. 1-4, 2009.
- [12] C. Tanaphatsiri, W. Jaikla, "Electronically tunable four phase quadrature oscillator employing current-controlled current conveyor transconductance amplifiers," Sixth IEEE International Symposium on Electronic Design, Test and Application, pp. 89-92, 2011.
- [13] D. R. Frey "Log-domain filtering: an approach to current-mode filtering," IEE Proc. Cir. Dev. Syst., vol. 140. pp. 406-416, 1993.