

Comparative Study of Evolutionary Model and Clustering Methods in Circuit Partitioning Pertaining to VLSI Design

K. A. Sumitra Devi, N. P. Banashree, and Annamma Abraham

Abstract—Partitioning is a critical area of VLSI CAD. In order to build complex digital logic circuits its often essential to sub-divide multi –million transistor design into manageable Pieces. This paper looks at the various partitioning techniques aspects of VLSI CAD, targeted at various applications. We proposed an evolutionary time-series model and a statistical glitch prediction system using a neural network with selection of global feature by making use of clustering method model, for partitioning a circuit. For evolutionary time-series model, we made use of genetic, memetic & neuro-memetic techniques. Our work focused in use of clustering methods - K-means & EM methodology. A comparative study is provided for all techniques to solve the problem of circuit partitioning pertaining to VLSI design. The performance of all approaches is compared using benchmark data provided by MCNC standard cell placement benchmark net lists. Analysis of the investigational results proved that the Neuro-memetic model achieves greater performance then other model in recognizing sub-circuits with minimum amount of interconnections between them.

Keywords—VLSI, circuit partitioning, memetic algorithm, genetic algorithm.

I. INTRODUCTION

ADVANCES in semiconductor technology and in the integration level of integrated circuits have enhanced many features, increased the performance; improved reliability of electronic equipment, and at the same time reduced the cost, power consumption and system size. As size and complexity of digital system has increased, more computer aided design tools are introduced into hardware design processes. The designers extensively rely on software tools for nearly every aspect of the development cycle, from circuit specification and design entry to the performance analysis, layout generation and verification. Partitioning is a problem that runs central to VLSI design automation, and one that has attracted a great deal of interest; a recent survey [1]

K. A. SumithraDevi is with RVCE, Visvesvaraya Technological University, Head & .Prof., Department of MCA, Bangalore, India (phone:+919945004632; e-mail: sumithraka@hotmail.com).

Banashree N. P. is with RVCE, Visvesvaraya Technological University, Lecturer, Department of MCA, Bangalore, India (phone:+919880108193; e-mail: banashreenp@yahoo.com).

Annamma Abraham is with RVCE, Visvesvaraya Technological University, Asst. professor, Department of MCA, Bangalore, India (phone: +919448970039).

lists almost 200 papers on the subject. In sub-problems, are Iterative improvement algorithms, such as

- Kernighan-Lin (KL) algorithm [3]
- Fiduccia-Mattheyses (FM) Algorithm [4]
- Simulated Annealing
- Genetic Algorithms

VLSI circuit partitioning is a vital part of physical design stage. The essence of circuit partitioning is to divide the circuit into a number of sub-circuits with minimum interconnections between them. This can be accomplished by recursively partitioning a circuit into two parts until we reach desired level of complexity. Thus two way partitioning is basic problem in circuit partitioning, which can be described as [2]. This paper proposes a different approach to solve circuit partitioning problem. We made use of evolutionary algorithm & clustering approach .It is trained to learn useful sub-circuits with lowest amount of interconnections between them

II. IMPLEMENTATION

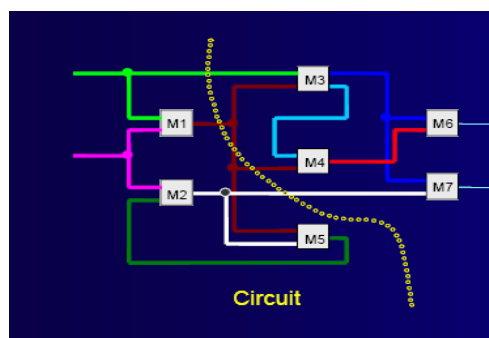

Fig. 1 Bipartition Circuit

The system consists of three parts, each dealing with data extraction, Learning stage & result stage. In data extraction, a circuit is bipartite and chromosomes are represented for each sub circuit. Extracted sequence are fed to Neuro-Memetic model [12], memetic, genetic approach separately that would recognize sub-circuits with lowest amount of interconnections between them .A sample example and the corresponding chromosome representation is shown in Fig. 2. And Fig. 3

Sub circuit 1 M1, M2, M5 total edges = 9
Sub circuit 2 M3, M4, M6, M7 total edges =13

Cell	No of edges	Bipartition
M1	3	1
M2	3	1
M3	4	1
M4	3	1
M5	3	1
M6	3	0
M7	3	0

Chromosomes representation

Sub circuit1 (M1, M2, M5) 0010 0010 0011

Sub circuit2 (M3, M4, M6, M7) 0011 0011 0100

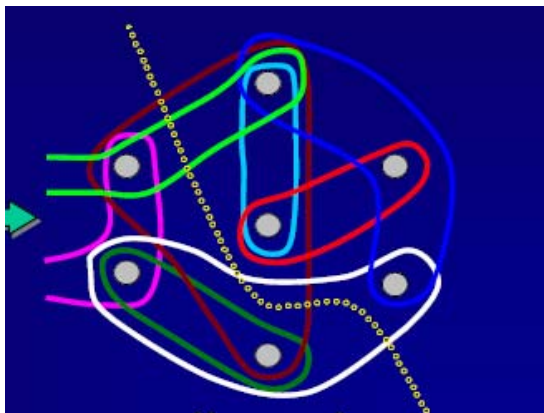

Fig. 2 Hyper graph Partitioning Circuit

III. EVOLUTIONARY ALGORITHMS

This section explains about the fundamentals of evolutionary algorithms such as genetic algorithm, memetic algorithm, and local search heuristics employed in this paper.

A. Genetic Algorithms

Genetic Algorithm (GA) is a search algorithm based on the principles of evolution and natural genetics. Genetic Algorithms combine the exploitation of past results with the exploration of new areas of the search space [5]. The effectiveness of the GA depends upon an appropriate mix of *exploration* and *exploitation*. Three operators to achieve this are: selection, crossover, and mutation. Selection according to fitness is the source of exploitation. The mutation and crossover operators are the sources of exploration. As the mutation rate increases, mutation becomes more disruptive until the exploitative effects of selection are completely overwhelmed.

B. Memetic Algorithms

Memetic algorithms (MAs) are optimization techniques based on the synergistic combination of ideas taken from other metaheuristics, such as population search (as in

evolutionary techniques), and local search (as in gradient-ascent techniques). [7][8]. MAs are designed to search in the space of locally optimal solutions instead of searching in the space of all candidate solutions. This is achieved by applying local search after each of the genetic operators.

C. Neuro-Memetic Approach

Neuro-memetic model makes it possible to predict the sub circuit from circuit with minimum interconnections between them which is given in detail [12].

1. Training Procedure

Adjusting the input and output parameters of the Neural network model, so that the MAPE (Mean Absolute Percentage Error) measure is minimized this is a major endeavor of training. Back propagation learning algorithms is employed for training. Most often; the error surface becomes trapped to local minima, usually not meeting the desired convergence criterion [12]. The termination at a local minimum is a serious problem while the neural network is learning. In other words, such a neural network is not completely trained [5]. Memetic algorithms is proficient search method for intricate (i.e., possessing many local optima) spaces to find nearly local optima. Thus, its ability to find a better suboptimal solution or have a higher probability to obtain the local optimal solution makes it one of the preferred candidates to solve the learning problem.

2. Training with MA

The parameters of the neural network are tuned by a memetic algorithm with arithmetic crossover and non uniform mutation. We have attempted to improve our previous work [12] by considering population (P) with 300 genotypes and fixing iteration 325. We ran MA for 325 generations with the same population size. The best model was found after 56 generations. The probability of crossover is 0.56 and the probability of mutation is 0.2 is used. These probabilities are chosen by trial and error through experiments for good performance. The new population thus generated replaces the current population. The above procedures are repeated until a certain termination condition is satisfied. The number of the iterations required to train the proposed MA-based Neural network is 1300 compared to 2000 as in [12]. The range of the fitness function of neural network is [0, 1].

3. Evaluate Individuals Using the Fitness Function

The fitness of a chromosome for the normal class is evaluated as depict [12] as in shown example.

Take testing samples

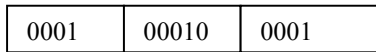

Now take the sub circuit 1 -- data set (d1)

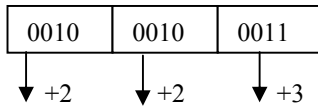

For sub circuit 2 --dataset d2

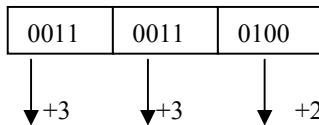

Calculate the sum of (+) credit & (-) debit for each sample data d1 & d2

For d1 = +2+2+3=7

d2 = +3+3+2=8 so it has found that **sample fitness of data d1** is best sample.

The present work involves the development of neural network, which can train to recognize sub circuit with minimum interconnection between them from large circuit given.

4. Artificial Neural Networks

In the context of recognition of sub circuit with minimum interconnection, the 3-layer neural network is employed to learn the input-output relationship using the MA [12]. Neural network contains 12 input nodes, 20 neurons in the first hidden layer, 14 neurons in the second hidden layer and the output layer has 2 neurons. It results in a 12-14-2 Back propagation neural network [12]. Sigmoid function is used as the activation function. Memetic Algorithm is employed for learning [6]. The learning rate is 0.2; the momentum constant is 0.9 for back-propagation [12]. During the training progression, the performance is 0.00156323 at 2000 epochs.

IV. CLUSTERING TECHNIQUES

Clustering is alternatively referred to as unsupervised learning segmentation [7]. It can be thought of as partitioning or segmenting the data into groups that might or might not be disjointed. The clustering is usually accomplished by determining the similarity among the data on predefined attributes. The most similar data are grouped into clusters. The clustering is usually accomplished by determining the similarity among the data on predefined attributes. The most similar data are grouped into clusters. In this paper K-means and Expectation Maximization algorithms are applied on different data sets with neural network. K-means is an iterative clustering algorithm in which items are moved among sets of clusters until the desired set is reached [8]. **Expectation Maximization Algorithms** Algorithm is similar to K-mean

procedure in that sets of parameters are re-computed until desired Convergence value is achieved.

V. RESULTS AND OBSERVATION

In data extraction, a circuit is bipartite and chromosomes are represented for each sub circuit. Extracted sequence are fed into evolutionary time-series model and clustering approach with neural network train the network that would recognize sub-circuits with lowest amount of interconnections between them. The bipartition programs were tested on the MCNC standard cell placement benchmark net lists. Table I shows performance of proposed compared evolutionary time-series model to clustering approach.

TABLE I
PERFORMANCE EVALUATION OF MEMETIC AND NEURO-MEMETIC

Methodology	Average cut performance	Min Cut size	Run times Performance
Evolutionary model	Very less	Maximum	Greater
Clustering model	More	Minimum	Less

VI. CONCLUSION

In this paper the Circuit Partitioning problem is implemented using Evolutionary & clustering approaches as well as their performance is evaluated. The strength of the Evolutionary model in recognition of sub circuit with minimum interconnection detailed above. Experimental results showed that the proposed mechanism developed using Neuro-memetic algorithm has been very effective, especially in the case of a large number of cells when compared with other models. The proposed model based algorithm has achieved very low minimum cut, for the Circuit Partitioning problem. In our previous work we made use of Neuro-Memetic approach [12] which gives a better cut size for most case with minimum generation (after 56 generation) compared to other [12] which is 200.

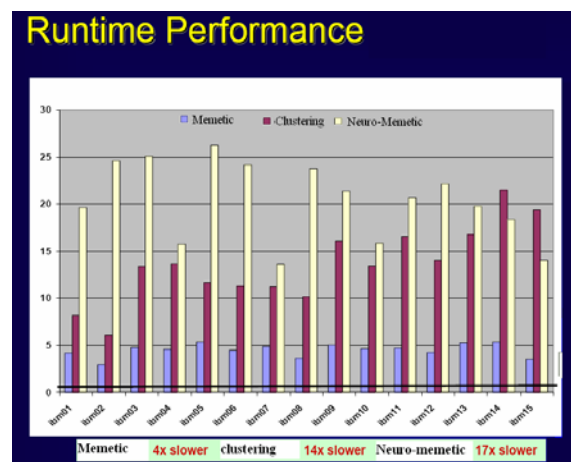

Fig. 3 Runtime performance for neuro-memetic, memetic & clustering model

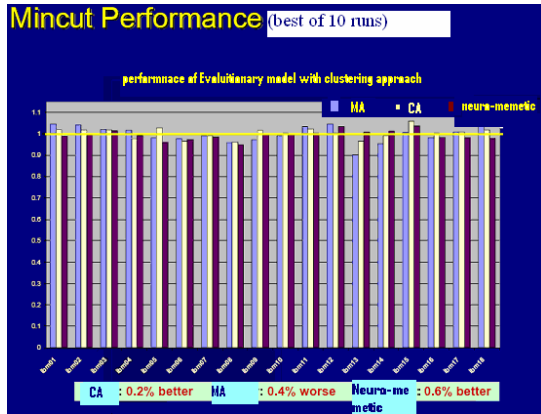

Fig. 4 Min cut performance for neuro-memetic, memetic & clustering model

From experimental result it had been found that runtime performance of Neuro-memetic model is greater than memetic and clustering model shown in Fig. 3. Average cut performance is lowest in evolutionary model compare to clustering approach which is depict in Fig. 5. In Fig. 4 it is clearly show that min-cut performance for evolutionary model is more compare to clustering approach.

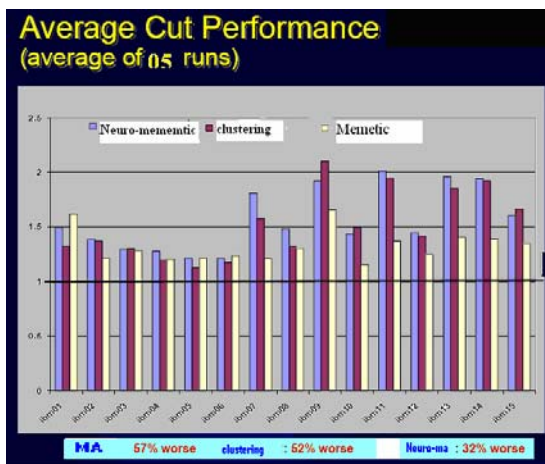

Fig. 5 Average cut performance for neuro-memetic, memetic & clustering model

REFERENCES

[1] C. J. Alpert and A. B. Kahng, "Recent Directions in Net list Partitioning: A Survey," *Integration: the VLSI Journal*, 19(1-2), 1995, pp. 1 – 81.

[2] Pinaki Mazumber, Elizabeth M. Rudnick, "Genetic Algorithms for VLSI Design, Layout & Test Automation", Prentice Hall PTR, 1998.

[3] B. W. Kernighan and S. Lin, "An Efficient Heuristic Procedure for Partitioning Graphs", *Bell System Tech. Journal*, vol. 49, Feb.1970, pp. 291-307.

[4] C. M. Fiduccia and R. M. Mattheyses, "A Linear-time heuristic for Improving Network partitions", *Proc. ACM/IEEE Design Automation Conf.*, 1982, pp 175-181.

[5] H. K. Lam, S. H. Ling, F. H. F. Leung and P. K. S. Tam, "Tuning of the structure and parameters of neural network using an improved genetic algorithm", in *Proc. 27th Annual Conf. of the IEEE Industrial Electronics Society (IECON 01)*, Denver, Colorado, 29 Nov.-2 Dec. 2001, pp. 25-30.

[6] N. J. Radcliffe, and P. D. Surry, "Formal Memetic Algorithms," *Evolutionary Computing*, Springer-Verlag, Berlin, 1994, pp 1-16.

[7] Data Mining by Bhavani Thuraisingham

[8] Ordonez.C, Omiecinski.E "Efficient disk-based K-Means clustering for relational databases"

[9] M. Srinivas and K. M Patnaik, "Genetic algorithm a Survey", *IEEE comput*27, 1994, 17-26.

[10] S. S. Iyehgar, L. Prasad & D. Mortan in S. S. Iyengar, ed, 'Structure of Genetic Algorithm in Biological System" (CRC press, 1992).

[11] T.T Chow, Z. Lin, C.L song & G. Q. Zhanan Huhun, "Applying neural network & Genetic algorithm in chiller System optimization", *IEEE Paper June*1997.

[12] Prof K. A Sumithra Devi, N. P. Banashree & Dr Annamma Abraham, "An Evolutionary time-series Model for partitiononig a Circuit pertaining to VLSI Design using Neuro-memetic Algorithm" , in *proc. 4th IASTED International Conference on Circuit, Signal & System*, San Francisco, USA, 20 Nov.-22 Nov .2006, pp 325-329.