

Representation of Power System for Electromagnetic Transient Calculation

P. Sowa

Abstract—The new idea of analyze of power system failure with use of artificial neural network is proposed. An analysis of the possibility of simulating phenomena accompanying system faults and restitution is described. It was indicated that the universal model for the simulation of phenomena in whole analyzed range does not exist. The main classic method of search of optimal structure and parameter identification are described shortly. The example with results of calculation is shown.

Keywords—Dynamic equivalents, Network reduction, Neural networks, Power system analysis.

I. INTRODUCTION

POWER system by transient calculations mostly is represented with the simplification of structure (invariability) and parameters of system components. In many cases single elements of such systems are represented detailed with big accuracy and the remaining part of system is replaced by simply equivalent network. Such inaccurate modeling of system may cause incorrect results of calculations. Transitional phenomena are omitted at changes of subsequent configurations from operations of power system protection automation and the simple sequence is taking into consideration.

Such simplification can cause erroneous results of analyses, particularly during fault calculations i.e:

- multiple faults
- unsimultaneous short-circuits,
- action of switching automation,
- load reaction during disturbances.

In available computer programs mostly are offered the equivalent system representing by short-circuit impedance. In NETOMAC program [1] the identification of parameters is offered, however without indication how to determine the basic structure of equivalents. The method proposed in DYNRED program [2] is also not adequate because of assumption of linearity and invariability of every component

Manuscript received March 31, 2008. This work was supported by the Ministry of Science and Higher Education (Warsaw, Poland) as investigative project 2007-2008 (under Grant N511 006 32/1426).

P. Sowa is the head of the Section: Automation and Informatics in Electric Power Engineering, Institute of Power Systems & Control, Silesian University of Technology, Poland (phone: +48323471625; e-mail: Pawel.Sowa@polsl.pl).

in system. During analysis of system failure, mathematical description in whole range of change from start to damping of transients is very complex. In reality the individual elements of systems have different mathematical representation during whole transients depending on analyzed phenomenon. The range of time phenomenon is very wide from microseconds for hours, even days. For every kinds of phenomena exists separate model representing individual element of power system. One of the most remarkable aspects of transient analysis is the fact that a single physical component may have different model representations depending upon the context of the problems. For instance model of transmission line for electromagnetic transient calculation must take into account the distributed character of line with frequency dependent parameters. In addition for analysis of very fast electromagnetic phenomena e.g. during lightning, the corona effect with nonlinear character of line capacitance must be included into transmission line model. In opposite for electromechanical transient calculation, the transmission line can be represented as one PI equivalent system. Of course the distribution of phenomena show in Fig. 1 is conventional.

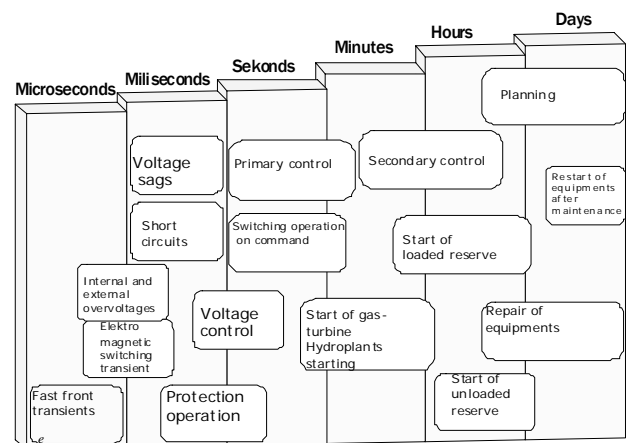

Fig. 1 Chosen states of power system – conventional distribution

After decomposition of system on islands – because of blackout the representation of transients could be full and complex without any simplification according to analyzed range of phenomena. For computational analysis during restitution there is necessary to find the equivalent for external part of system. However, it will require procedure for verification of such equivalent, that results will be identical as for original system without any simplification.

II. MODEL OF SYSTEM FOR FAULT CALCULATION

In dynamic transients studies only a small portion of a transmission system can be modeled in detail. The simulation of extremely extensive and complex network configurations will call in question the accurate modeling of each network element. The reduction of the network leads to some inaccuracies of the obtained computed results. It is therefore important to find a compromise between the accurate and reduced network representation for each transient fault analysis, according to the analyzed case and the foreseen utilization of the results. The network equivalent model development originates from the need to have readily available detailed only those component they are of primary interest. As mentioned above one of the most frequently used is such an arrangement where the remaining power system with reference to the object being under study is a lumped impedance determined from the given short-circuit level at the object terminals. This impedance, usually calculated for the rated frequency, is obviously not a satisfactory representation of complex network configurations. The principle idea of the reduction of complex system is shown in Fig. 2.

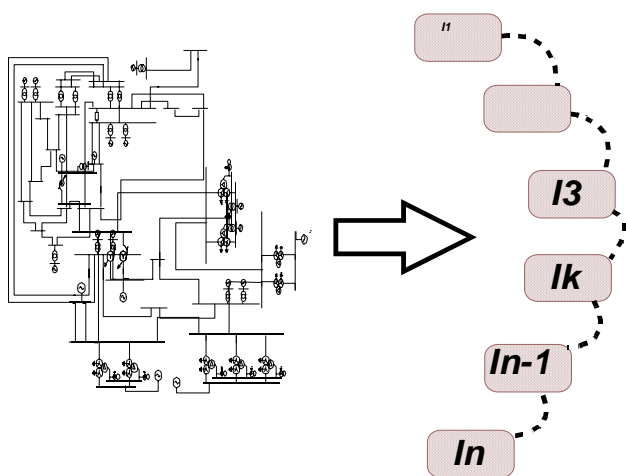

Fig. 2 Idea of reduction of complex system

Nowadays the best computer programs, which are at disposal for transients simulations can be used for the calculations in electrical power systems with more than ten or more thousand nodes, but the biggest problem is to find the data of each elements of system. Therefore it is very important to find a simplified and verified equivalent network of power systems. However, very seldom-real measurements were used for the identification of equivalent network parameters.

Generally there is not at disposal the optimal structure of equivalent network for the investigation of electromagnetic transients in electric power transmission system. Sometimes the replacement of a complex network by a simple equivalent system can be a hazard, but sometimes the results received in simply equivalent system are more exactly compared with the results received in the complex equivalent system.

The choice of the right equivalent method influences the measuring accuracy and exact representation of the current and voltage waveforms. In many papers the research attempts

have concentrated on frequency or time domain methods. In Fig. 3 are classified the most known equivalent solution methods. Important is that mostly the frequency domain methods are used for the search of the structure but the time domain methods for identification of parameters of the equivalents structure.

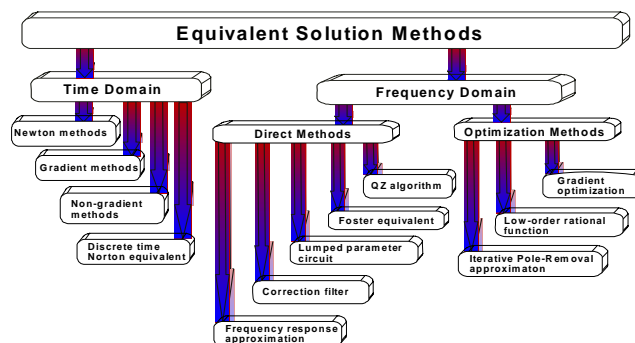

Fig. 3 Equivalent solution methods

After many investigations [3] the following conclusions must be taken into consideration:

- the frequency domain methods do not represent properly the system behavior during non-simultaneous fault,
- the optimization using time domain methods cannot be practicable by the search of the equivalent network for the electromagnetic transient investigations only for the identification of parameter of equivalent system,
- the idea of frequency domain equivalent approximation is not acceptable for the systems with non-linear parameters.
- the optimum structure of the equivalent network cannot be obtained for the calculations of the electromagnetic transient.

The system model in time domain is in the form of differential equations. In this case the time domain response of the external system is utilized to identify a discrete-time model of the system. The biggest problem is the identification of parameters of the equivalents structure. Three different deterministic optimization methods have been used for identification of the parameters for reduced networks (Fig. 4):

- principles of least-squares criterion,
- quasi-Newton methods,
- Powell's algorithm without derivatives.

The effectiveness of parameter identification for reduced equivalent networks depends upon the:

- model structure,
- number of parameters,
- "length" of the computational step,
- number of relative function minima,

Using the parameter identification techniques the optimal reduced model can be obtained to find the fault transient solution for any given power system configuration. If the

identification action is not successful, then the new initial value should be given to reach global minimum error, otherwise the basic structure of the selected model must be changed.

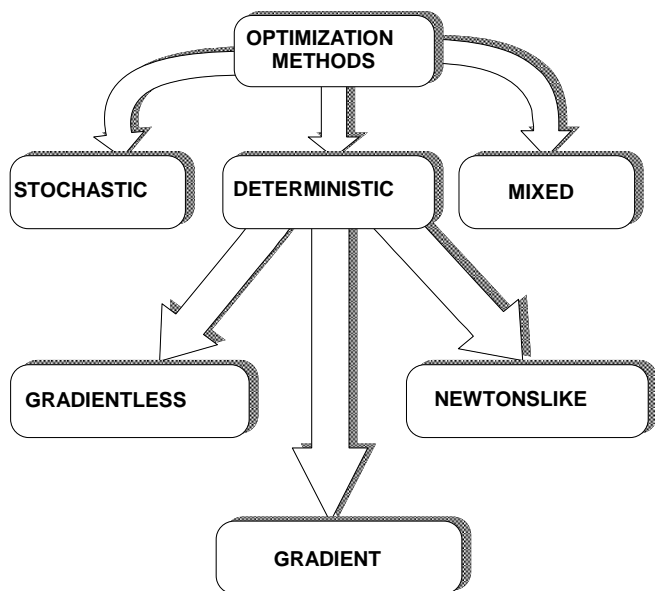

Fig. 4 Optimization Methods in Time Domain

III. CONCEPTION OF ELECTROMAGNETIC TRANSIENT REPRESENTATION DURING RESTITUTION

Very important problem of investigations of electromagnetic and electromechanical transient during fault conditions, can be solved only under following three conditions:

- results are given from measurements,
- results are given from calculations made in complex system without any simplification with detailed representation of each element of system,
- results are given from calculations received in equivalent network.

First condition is mostly not possible for realization because of technical, economical and security reasons. A second condition is also mostly not possible, because of the problem to get the data of each element of big power system. Third condition is possible after verifications of results received in equivalent network with the help of comparison with measured or calculated results in primary (not reduced) system. Such presented conclusions are not optimistic for the use of any classic method of optimization for the search of structure and identification of parameter of equivalent system. The requirements of power system representation for restitution study are very high and it can be impossible to find good enough model for all conditions during this phenomena.

Necessity of search of properly exact equivalent for this situation, which should replace some island received after system failure gives the state of choice of “core” of system in which all elements should be represented in detail but the remaining part of system must be represented by equivalent. The structure of equivalent can be determined in frequency

domain but the parameter identification is made in time domain. If identification of parameter of definite scheme is not successful then it belongs to start optimization for different equivalent structure.

The new idea for the range of electromechanical transient using artificial neural network (ANN) [4] determines the new direction of search of solution also for the range of electromagnetic transient. In this idea, a new approach for optimizing of equivalent network using ANN is presented. The objective is to replace part of systems by suitable universal ANN-based dynamic equivalents. The ANN proposed to represent all elements in part of network has been trained by time series. For this purpose, a number of non-simultaneous three-phase short circuits were simulated at different nodes in the internal network. The calculations were later repeated for the reduced network, however the reduction was made for the area marked in Fig. 5. As analytical tools for the investigations were chosen:

- MicroTran Programm,
- QwikNet Version 2.23 Artificial Neural Network for Windows.

With the help of MicroTran [5] were made the calculations of transients during faults in chosen nodes. For the identification of ANN equivalent network was used the QNet – package program. QwikNet is simulator using Artificial Neural Network (ANN). QwikNet and implemented several methods give the possibility to train and test a standard feed-forward neural network. With the help of training a neural network it is easy to make the determination of appropriate set of weights so that the network accurately approximates the input/output relationship of the training data.

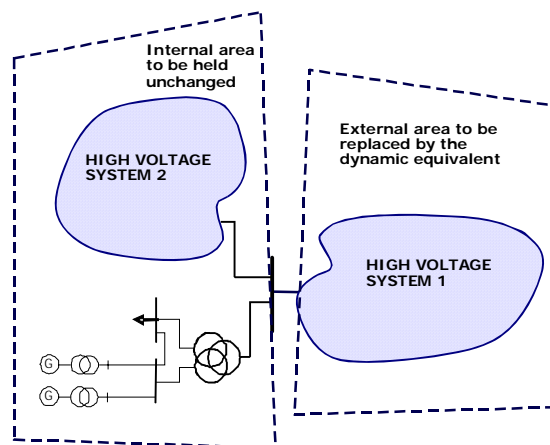

Fig. 5 Principles of the proposed dynamic equivalency approach

The choice of training method can have a substantial effect on the speed and accuracy of training. The best choice is dependent on the problem, and usually trial-and-error is needed to determine the best method. The learning rate, η , controls the rate at which the network learns. The RPROP and Delta Bar Delta algorithms update this parameter adaptively. The momentum parameter, α , controls the influence of the last weight changes on the current weight update. Momentum

usually results in faster learning, but can cause instability in some cases if set too large. The amount of Gaussian noise to be added to the input training patterns. Training with a small amount of noise (sometimes called jitter) helps prevent over fitting and usually improves generalization. The amount of weight decay in the training algorithm: Weight decay tends to decrease large weights in the network and usually improves generalization.

The results of calculations from MicroTran program were send to input of QwikNet program and then after many approaches the neural network was adjusted. The best results were received with the help of Online Backprop – Rand algorithms.

In Fig. 6 are shown for comparison transient voltage during fault calculated in primary and reduced system. It is clear that very good results – almost the same - values received in both systems, shown the rightness of assumed methods of calculations and optimization.

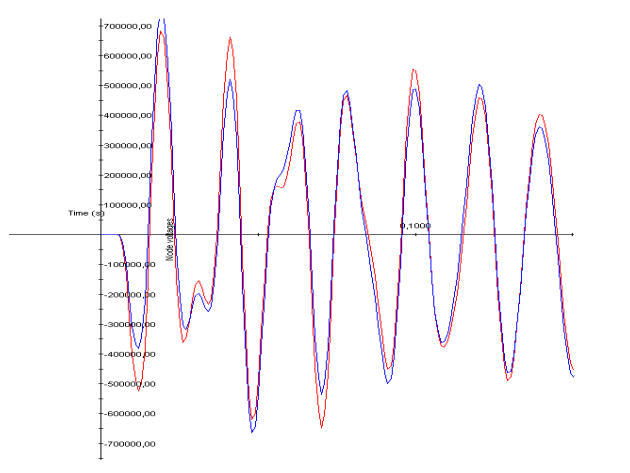

Fig. 6 Transient voltages calculated in origin and reduced system

IV. FINAL REMARKS

In presented paper the new idea of universal models of power system for dynamic calculation during failure and restitution is shown. Methods of searches of equivalents behind assistance of known method in time domain and frequency domain are not applicable for solution of transients during complex fault conditions. The new method taking advantage ANN has been verified for analysis of dynamic electromagnetic phenomenon. Computational tests gives good results by comparison of results received in primary and reduced system.

REFERENCES

- [1] B.Kulicke, H.-J.Hinrichs, "Parameteridentifikation und Ordnungsreduktion mit Hilfe des Simulationsprogramms Netomac", etzArchiv Bd. 10 (1988) H.7, s.207-213.
- [2] G.J.Wong, D.Y.Ottevangers, J. Wang, L. "Dynamic reduction, Version 1.0", EPRI-TR-102234-Vol.1, Technical Report, 1993 Apr 01.
- [3] P.Sowa, Search of Optimum Equivalent Representation for Transient Investigations during non-Simultaneous Faults", Proceedings of the IASTED, Int. Conference Modeling and Simulation, Pittsburgh, USA,

1998, IASTED/ACTA Press, ISBN: 0-88986-252-4, ISSN: 1021-818, pp.466-470.

- [4] A.M.Azmy, I.Erlich, P.Sowa, "Artificial Neural Network-Based Dynamic Equivalents for Distribution Systems Containing Active Sources", IEEE Power Systems, 2004.
- [5] MicroTran, Transients Analysis Program for Personal Computers, MicroTran Power System Analysis Corporation, Published, June 1991, Vancouver, B.C., Canada.



Pawel Sowa (M'1998) received his Dipl.-Ing. degree in electrical engineering from the Silesian University of Technology (SUT)/Poland in 1971. After his studies, he joined the Institute of Power Systems & Control in SUT, Poland, where he received his PhD degree in 1980, and D.Sc. degree in 1997. Since 1999, he is Professor and head of the Section Automation and Informatics in Electric Power Engineering in Institute of Power Systems & Control in SUT. His major scientific interest is focused on modeling and digital simulation of faults and emergency conditions in electric power systems, development and optimization of power systems protection and local control schemes. Since 2003 he is also Vice-Dean for Scientific and Organization in Electrical Faculty of SUT. He is a member of IASTED and IEEE.