

Switched Reluctance Generator for Wind Power Applications

M. Nassereddine, J. Rizk, and M. Nagrial

Abstract—Green house effect has become a serious concern in many countries due to the increase consumption of the fossil fuel. There have been many studies to find an alternative power source. Wind energy found to be one of the most useful solutions to help in overcoming the air pollution and global. There is no agreed solution to conversion of wind energy to electrical energy. In this paper, the advantages of using a Switched Reluctance Generator (SRG) for wind energy applications. The theoretical study of the self excitation of a SRG and the determination of the variable parameters in a SRG design are discussed. The design parameters for the maximum power output of the SRG are computed using Matlab simulation. The designs of the circuit to control the variable parameters in a SRG to provide the maximum power output are also discussed.

Keywords—Switched Reluctance Generator, Wind Power, Electrical Machines.

I. INTRODUCTION

CLIMATE change is a contemporary issue, and the international community have accepted the dangers of green house gas emissions. Methodology and policies on how to address this important issue is now a popularly debated topic. Renewable energy is one of the hot topics when it comes to dealing with green house gas emissions treatments. Wind generation is one of the renewable energy power source that helps in reducing the carbon dioxide from our atmosphere.

The existing research shows that in the past decades the wind generation has become one of the hot topics in Australia and word wide, [1,2] the reason behind that is:

- The construction and installation of the wind generator has the lowest environmental impact of all energy sources; it occupies less land area per KWH than any other energy source apart from the rooftop solar energy.
- The green house effect of wind energy generator (WEG) is almost negligible compared with any other energy sources.
- Short time for construction and long work life
- Low cost and maintenance
- By using WEG it will help reduce the air pollution by reducing the carbon dioxide into our air.
- Due to the modern electronics, electrical and mechanical equipment the control of is excellent.

Authors are with School of Engineering, University of Western Sydney, Locked bag 1797 Penrith South DC NSW 1797 (e-mail: j.rizk@uws.edu.au).

One of the biggest challenges that exist in wind generation is the wind generator; the permanent magnet generator is the most commonly used one. It required high torque to run, “the higher the power capacity the higher is the torque” and to overcome this problem switched reluctance motor generator is being investigated as a possible contender for such applications, the advantages of the switched reluctance generator is that no starting torque required to start.

II. ADVANTAGES OF SRG

According to the existing research; most of the small wind turbine generators use a permanent magnet machine which has a cogging torque (T_c) due to the existence of a permanent magnet. Cogging torque is the force that created between PM and a metal due to the PM characteristics [1-5].

The aerodynamic power that will be produced by the wind; which can be calculated using the equation below; has to overcome the cogging torque:

The aerodynamic power

$$W = \frac{1}{2} \rho C_p V^3 \quad (1)$$

Where ρ is the density of air, A is the swept area of the blade, C_p is the performance coefficient and V is the wind speed.

In order for a PM generator to operate, W must be greater than the cogging torque ; By replacing the PM generator by a switched reluctance generator $W > 0$ in order for the generator to operate; that means the required energy to overcome the cogging torque in a PM generator can be used to produce power in a switched reluctance generator. The power saved will be equal:

$$P = T_c \cdot \omega, \quad (2)$$

Where T_c is the torque and ω is the angular velocity of the rotor.

The angular velocity of the rotor will be equal to the angular velocity of the blade if no mechanical gear were used. Equation (2) shows the energy that will be saved when replacing a PM generator by a SRG, and hence save losses. SRG can offer important advantages over conventional AC machines in generating power [3-5]; SRG shows a simplified construction associated with the absence of permanent magnet and winding in the rotor which leads to lower manufacturing costs; the lower inertia allows the machine to respond to rapid

variations in loads. The development of the power electronics and the advancement in the field of semiconductors brought improvement in the control technology of the SRG with rapid changes in the control strategy. The electrical and magnetically of each phase in a SRG are independent both electrically and magnetically; SRG has an inherent fault tolerance especially when under an open coil and in the power converter.

III. SRG SELF EXCITATIONS

The recent research shows that the switched reluctance generator (SRG) is inherently completely passive and has no self-excitation capability [6, 7]. To overcome this problem some researchers used a slot of permanent magnet on the edge of the stator pole to create a magnetic field that run through the rotor to both side of the stator; the rotation of the rotor will change the permanent magnetic flux which induces alternating voltage in the stator winding [8]. The others have chosen an external power source to help in self excitation for this SRG like using a battery or capacitor to create a magnetic field around the stator winding for a set time and then this magnetic field will be used to create electricity when the rotor moves.[8,9]

The approach in this study will take the option where no permanent magnet will be involved in the design of the SRG. Fig. 1 shows the stator winding of a four phases SRG. The figure shows the 8 stator poles with its relevant windings. Fig. 2 shows the poles of a 4 phase SRG rotor. This type is most common used type of SRG. The idea behind the SRG self excitation process is to have two phases in each electrifying period (excitation and generation).



Fig. 1 4 phases SRG stator poles and winding

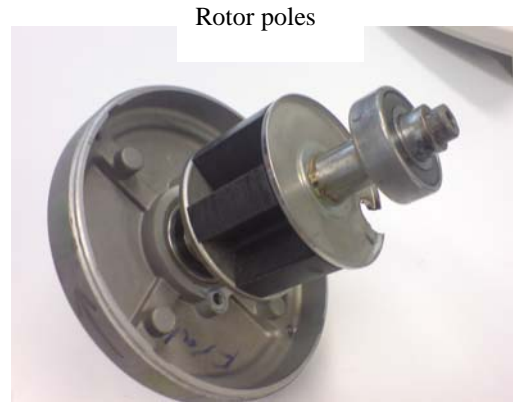

Fig. 2 Silent rotor poles of a 4 phases SRG

At the first stage of the electrified period the winding on the stator will be excited by outer power source, be represented by battery or capacitor. The electric energy that has been fed to the stator winding will convert into magnetic field energy; at the second stage of the electrified period, the magnetic field and mechanical energy will be converted into electrical energy feeding back to the load or storage source. The control of these staged during one period is very flexible due to the availability of power electronics switching. The instantaneous output power in a SRG is a function of the inductance L , the position of the rotor θ , the rotor speed ω and the number of phases n ; and can be expressed in equation (3) and the average resulting power can be drive from equation (4);

$$P(\theta, i_j) = \left[\frac{1}{2} \sum_{j=1}^n \frac{dL_j(\theta)}{d\theta} i_j^2 \right] \omega \quad (3)$$

$$P = T_m \times \omega \quad (4)$$

From the above equations; it is clear that the power depends on the inductance L that will be produced in the first stage of the electrified period the power will be diverging; When the SRG is into generating stage, the input electrical energy and the output mechanical energy are all in negative value, which means mechanical energy is converted into electrical energy.

The non-linear inductance model for SRG is based on the Fourier series of inductance; the inductance is a function of the excitation current and the rotor angle $L(\theta, i)$ as shown in Fig. 5. The value of the inductance is constant and periodic with period equal to $2\pi/P_r$ where, P_r is the number of rotor poles. By applying Fourier series and taken into consideration the symmetrical of the inductance about the y-axis in the section between $[-\pi/P_r, \pi/P_r]$, the following equations represent the relation between the inductance, the current and the rotor angle:

$$L(\theta, i) = L_0(i) + \sum_{n=1}^{\infty} L_n(i) \cos n P_r \theta \quad (5)$$

The result of the first 4 harmonics will be acceptable as a final result of the inductance calculation; therefore:

$$L(\theta, i) = L_0(i) + L_1(i) \cos Pr \theta + L_2(i) \cos 2Pr \theta + L_3(i) \cos 3Pr \theta \quad (6)$$

The value of the four unknown inductances can be derived from the 4 known values;

The maximum inductance value L_{\max} at $\theta=0$, minimum inductance value L_{\min} at $\theta=\pi/P_r$, the inductance value L_a at $\theta=\pi/2P_r$ and the inductance value L_b at $\theta=\pi/3P_r$

IV. CONTROL CIRCUIT FOR SRG

The voltage depends on the inductance L value and the inductance L depends on the excitation current. The excitation current value will depend on the capacitor type and the control circuit that allows the current to flow into the stator winding. The θ_{on} and θ_{off} will control the output power value of the SRG; also it does depend on the rotor speed; these facts give the SRG an advantage by having the ability to control its excitation stage which will have better performance when dealing with variable speed wind Turbine.

The recent research shows that there are few approaches to deal with the control phenomena in a SRG. There are ways to excite the SRG which is self-excited or separately excited. Fig. 3 and Fig. 4 show a self excited circuit and externally excited circuit that can be used in a SRG. In this study the self excited will be used [10, 11].

The analysis of the circuit in Fig. 3, depends on the switches operation mode. The circuit will be switching between excitation and generating power. The relation between the phase current and phase voltage can be expressed as follows:

$$\pm u_c(\theta) = i_a(\theta)r_a + \{L_a[\theta, i_a(\theta)] + \frac{\partial L_a[\theta, i_a(\theta)]}{\partial i_a(\theta)} i_a(\theta)\} \frac{di_a(\theta)}{dt} w + i_a(\theta) \frac{\partial L_a[\theta, i_a(\theta)]}{\partial \theta} w \quad (7)$$

Where r_a is the resistance of one phase winding in the generator; same analysis will apply to the rest of the phases.

The relationship between the voltage and the current in the load can be expressed in the following equation:

$$L \frac{di_R(\theta)}{d\theta} + \frac{i_R(\theta)R}{w} = \frac{u_c(\theta)}{w} \quad (8)$$

The relation between the voltage and the bus current can be expressed as follows:

$$\frac{du_c(\theta)}{d\theta} = -[i(\theta) + i_R(\theta)]/(wC) \quad (9)$$

The switching will be controlled using a PWM with a frequency range to prevent induction saturation in the stator winding.

V. SIMULATION AND EXPERIMENTAL RESULTS

From the previous paragraphs; the output power of a SRG will depends on many variables such as: the excitation current, the position of the rotor and the rotor speed. Equation (4) shows that the output power depends on the rotor position and the inductance L; the inductance L depends on the rotor position and the excitation current as shown in equation (5). Using MATLAB simulation to draw a graph to show the inductance characteristics with respect to the rotor position and excitation current, the power output is also shown of respect to the rotor position, the inductance of the stator winding and the rotor speed.

Fig. 5 shows the measured experimental result for the inductance L when applying different current at different rotor position. This figure shows that by increasing the current value the inductance will decrease for a fixed rotor angle. Fig. 6 shows the flux in the SRG as a of different current values and rotor position. According to this result by choosing different value of θ_{on} and θ_{off} will give largest or smaller magnetic field that can be converted into electric energy; also by minimizing θ_{on} and maximizing θ_{off} will be able to achieve a maximum value of the mechanical energy field that can be converted into electrical energy.

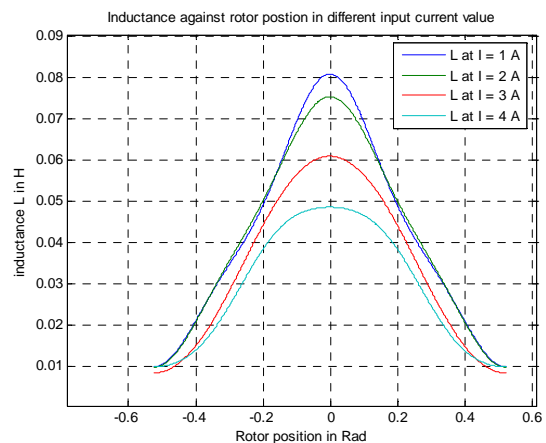

Fig. 5 Inductance vs rotor positions at different current

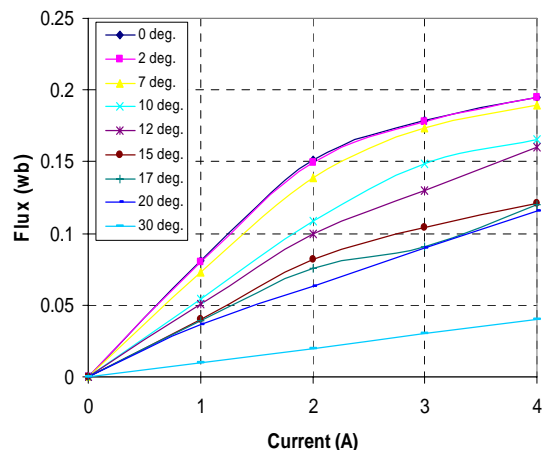

Fig. 6 Flux vs current in different rotor position

Fig. 7 shows the relation between the powers, rotor speed and rotor position for the tested SRG; as it shows that at certain value of θ the power output will be at its maximum value for different speed value. This shows, that in order to achieve the maximum power the $[\theta_{on}, \theta_{off}]$ should contain $\theta=0.12217$ Rad or 7 deg.

Fig. 8 shows the relation between the power, rotor speed and excitation current at a constant rotor position.

VI. CONCLUSION

From the experimental results it is clear that by controlling the variable parameters in the SRG to a certain value, it is possible to achieve the maximum power output of the machine thus increasing the efficiency of the system. The simulation power output results show that by choosing $\theta_{on} = -30$ deg and $\theta_{off} = 0$ deg the magnetic field that will be created in the stator winding will be at its maximum value. By choosing the interval $[\theta_{on}, \theta_{off}]$ to contain $\theta = 7$ deg the SRG's instantaneous power will be at its maximum. The output power will increase dramatically by increasing the excitation current. It also shows that by increasing the rotor speed the power will increase but not as much as when we increase the excitation current. Further study is continuing to obtain experimental results.

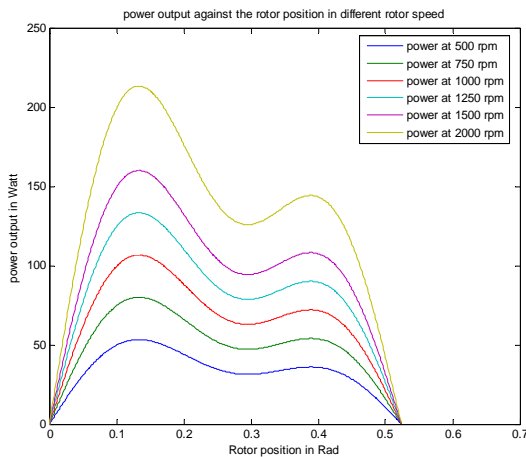

Fig. 7 Power, speed and rotor position graph

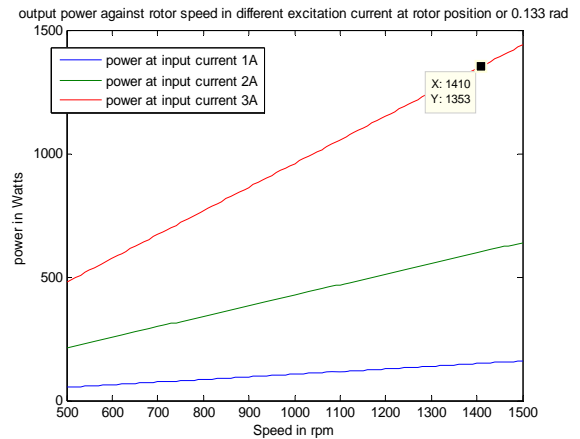

Fig. 8 Power vs speed at rotor position of 0.133 rad.

REFERENCES

- [1] P. Zai-pan, "Study on switch reluctance generator" Journal of Zhejiang University SCIENCE, ISSN 1009-3095, 2004.
- [2] Z. Qixue, "a small single-phase switched reluctance generator for wind power generation". ICEMS 2001 proceeding of the fifth international conference electrical machines and systems. 2001. VOL 2. Aug 2001 pages 1003-1006.
- [3] H. Chen, "Electromagnetic Design or Switch Reluctance Generator" IEEE, 0-7803-7885, 2003.
- [4] V. Nedic, "Experimental verification of induced voltage self excitation of a switched reluctance generator" Wisconsin power electronic research centre, WI 53706, USA, 2000.
- [5] A. Kumar, "Comparison of methods of minimization of cogging torque in wind generators using FE analysis" J. Indian Inst. Sci., Aug. 2006, 86, 355-362.
- [6] M.A. Mueller, "Design of low speed switched reluctance machines for wind energy converters". In Ninth international Conference on Electrical Machines and Drives. 60-64, 1999.
- [7] R. Cardenas, "Control of a Switched Reluctance Generator for Variable-Speed Wind Energy Applications", IEEE Transaction on energy conversion, Vol. 20, No. 4, December 2005.
- [8] P. Asadi M. Ehsani, "Design and Control Characterization of Switched Reluctance Generator for Maximum Output power", IEEE, 0-7803-9547, 2006.
- [9] D. A. Torrey, "Switched Reluctance Generators and Their Control", IEEE Transactions on industrial electronics, Vol. 49, No. 1, Feb, 2002.
- [10] J. Faiz, "Optimal Excitation Angles of a High Speed Switched Reluctance Generator by Efficiency Maximization", 1-4244-0121, 2006 IEEE.
- [11] Y. Chang "On the design of power circuit and control scheme for switched reluctance generator", IEEE transactions on power electronics, Vol. 23, Issue 1, 445-454, Jan. 2008.

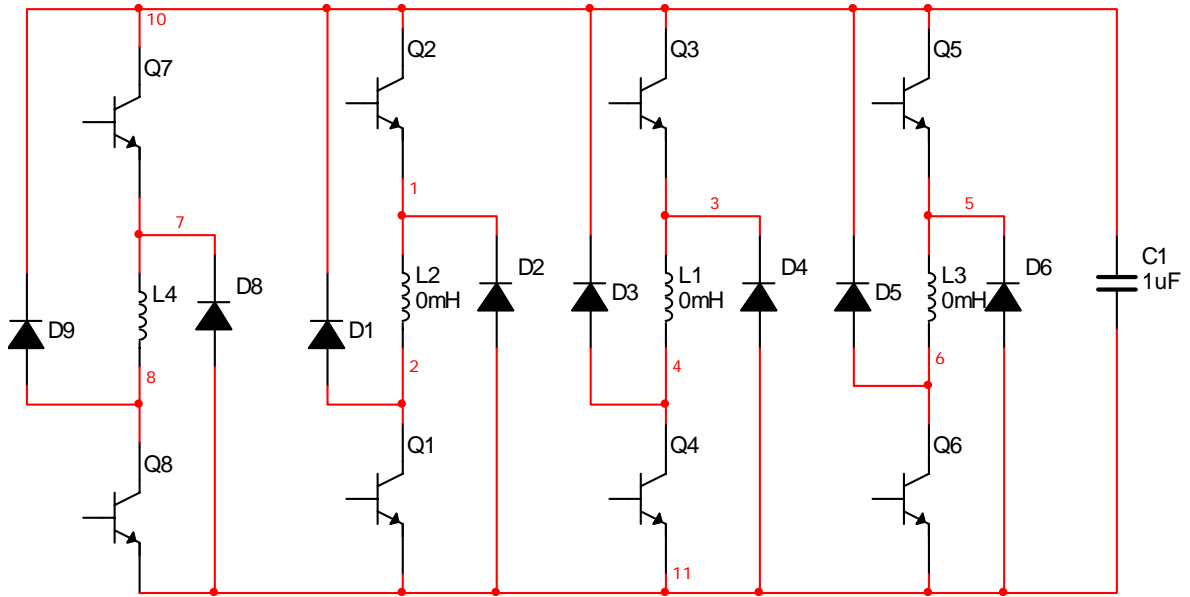

Fig. 3 SRG converter self excited

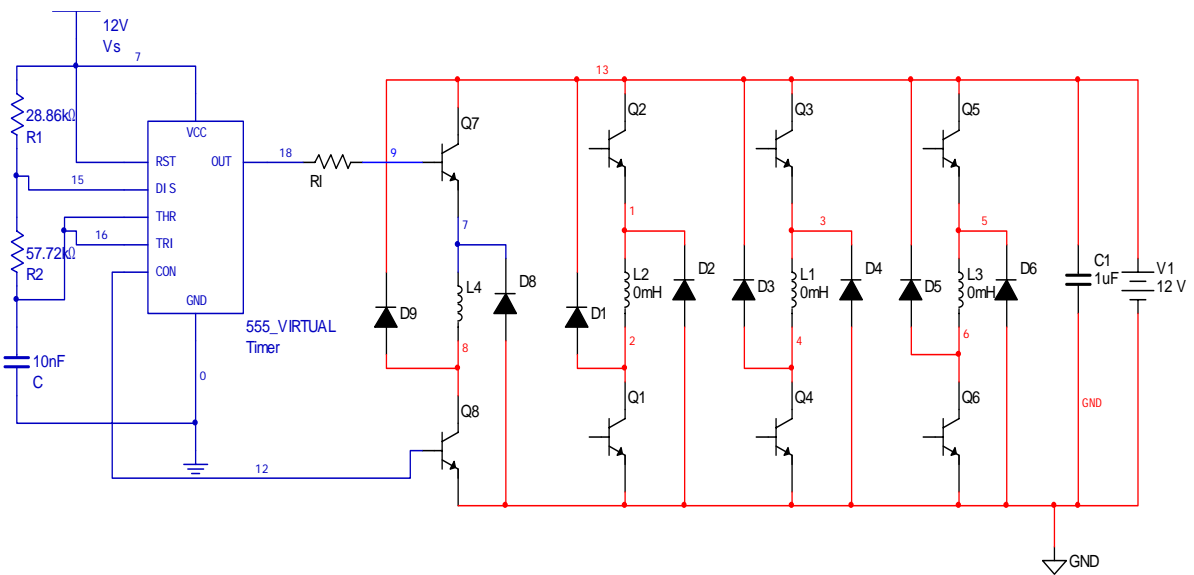

Fig. 4 SRG converter externally excited