

Energy Saving Suction Hood

I.Daut, N. Gomesh, M. Irwanto, Y. M. Irwan

Abstract—Public awareness towards green energy are on the rise and this can be prove by many product being manufactured or pre-required to be made as energy saving devices mainly to save consumer from spending more on utility billing. These schemes are popular nowadays and many homemade appliances are turned into energy saving gadget which attracts the attention of consumers. Knowing the public demands and pattern towards purchasing home appliances thus the idea of “energy saving suction hood (ESSH)” is proposed. The ESSH can be used in many places that require smoke ventilation or even to reduce the room temperature as many conventional suction hoods (CSH) do, but this device works automatically by the usage of sensors that detects the smoke/temperature and automatically spins the exhaust fan. As it turns, the mechanical rotation rotates the AC generator which is coupled together with the fan and then charges the battery. The innovation of this product is, it does not rely on the utility supply as it is also hook up with a solar panel which also charges the battery. Secondly, it generates energy as the exhaust fan mechanically rotates. Thirdly, an energy loop back feature is introduced to this system which will supply for the ventilator fan. Another major innovation is towards interfacing this device with an in house production of generator. This generator is produced by proper design on stator as well as rotor to reduce the losses. A comparison is made between the ESSH and the CSH and result shows that the ESSH saves 172.8kWh/year of utility supply which is used by CSH. This amount of energy can save RM 3.14 from monthly utility bill and a total of RM 37.67 per year. In fact this product can generate 175 Watt of power from generator(75W) and solar panel(100W) that can be used either to supply other household appliances and/or to loop back to supply the fans motor. The innovation of this system is essential for future production of other equipment by using the loopback power method and turning most equipment into a standalone system.

Keywords—Energy saving suction hood (ESSH), conventional suction hoods (CSH), energy, and power

I. INTRODUCTION

PHOTOVOLTAIC conversion is the direct conversion of sunlight into electricity without any heat engine to interfere [1]. Public awareness towards green energy are on the rise and this can be prove by many product being manufactured or pre-required to be made as energy saving

I.Daut is with Electrical Energy and Industrial Electronics Systems Research Cluster. Malaysia (phone: +6049797903 e-mail: ismail.daut@unimap.edu.my).

N.Gomesh is with Electrical Energy and Industrial Electronics Systems Research Cluster. Malaysia (phone: +6049797903 e-mail: gomesh@unimap.edu.my).

M.Irwanto is with Electrical Energy and Industrial Electronics Systems Research Cluster. Malaysia (phone: +6049797903 e-mail: irwanto@unimap.edu.my).

Y.M.Irwan is with Electrical Energy and Industrial Electronics Systems Research Cluster. Malaysia (phone: +6049797903 e-mail: irwanyusoff@unimap.edu.my).

devices mainly to save consumer from spending more on utility billing.

These schemes are popular nowadays and many homemade appliances are turned into energy saving gadget which attracts the attention of consumers. Renewable Energy resources are most preferable resources for generation of electrical energy because it is environmentally friendly. Of all the renewable energy resources, solar power is the most resource mainly because it is free, unlimited and free from pollution [2]. Approximately 80% of all photovoltaic (PV) systems are mended into a standalone system [3]. In spite being abundant and free, the solar energy does have its limitation of being dependant on the weather conditions and also unable to produce energy during night fall [4]. This is sometimes the reason a systems that is interfaced with solar panel is combined with another source producing element thus the name hybrid model [5]. The accumulated power from the hybrid system is then stored into a battery as a secondary source [6]. [1] describes hybrid power generation as a system that combines renewable energy source such as PV with other forms of generation which is usually a conventional generator powered by diesel or even another renewable form of energy like wind. The author also says that such hybrid systems serve to reduce the consumption of non renewable fuel. A hybrid PV system can also be termed as an alternative electrical source provider (wind, generator, etc) that can support the PV system in providing sufficient or added energy source. [7] investigates the flow field and deleterious substances by creating a new type of exhaust fan named the swirl air curtain exhaust fan (SACEH). Simulation results show that SACEH can effectively control the deleterious substances and greatly improve the suction

[8] has proposed using the developed nozzle wind collector associated with the popular roof turbine ventilator employed with gear mechanism to impact and vibrate a group of electro active material to generate electricity There are no similar researches done on hybrid PV system regarding the usage of mechanical rotation to generate energy other than the conventional usage of turbine. It makes this project a novel approach into the power generation development. This paper describes a new approach into PV hybrid system in which any external rotating devices is coupled to a generator to utilize the power generation. Another novel approach is applying both smoke and thermal sensors to automatically turn on the exhaust fan as it detects over than 25°C(room temperature) and more that 600 particles parts per million (ppm) of smoke.

II. ESSH SYSTEM LAYOUT

Based on Fig. 1, the power source consists of PV system as well as AC generator in which the accumulated power is

stored in a rechargeable battery. The design of suction hood has several phase of implementation which is:

- Design of the suction hood
- Programming of Sensors (microcontroller)
- Design of Energy saving generator
- Design of solar charger
- Hybrid model (Solar & AC Generator)

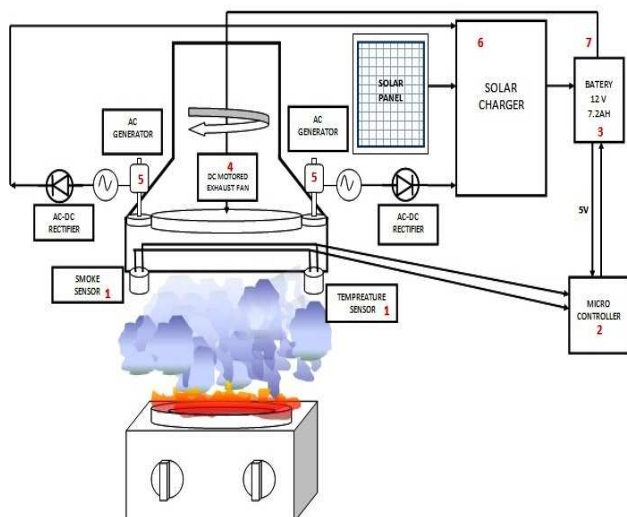

Fig. 1 Configuration of Energy Saving Suction Hood

III. WORKING PRINCIPLE

Fig. 2 shows the simplified projects overview on ESSH. As the Suction Hood detects smoke or/and temperature difference. It will automatically turn ON the suction hood to provide stable room temperature and smoke free environment.

The exhaust fan spins the coupled AC generator to produce 75W that will be rectified and then stored in the battery together with the solar power to either loop back to the exhaust fans or used to supply other equipment.

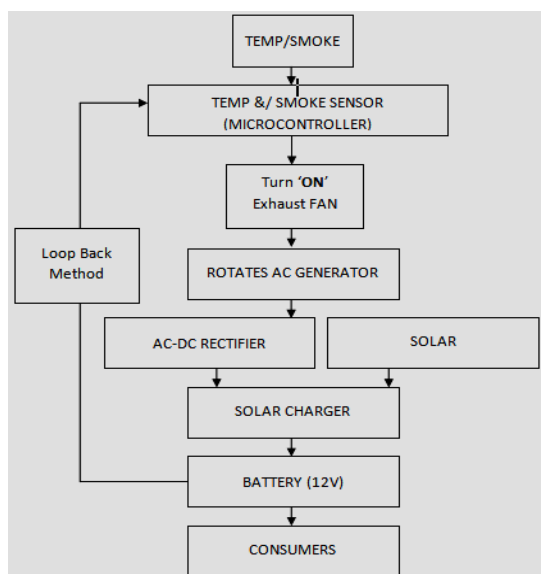

Fig. 2 Project Overview

IV. GENERATOR

Generators come in various types and sizes and for many purposes. A.C. generators or sometimes called the alternators operates the same fundamental principles of electromagnetic induction as D.C. generators. Alternating voltage may be generated by rotating a coil in the magnetic field or by rotating a magnetic field within a stationary coil. The value of the voltage generated depends on the number of turns in the coil, strength of the field. The speed at which the coil or magnetic field rotates. AC Generators takes in mechanical power and produces electric power unlike AC motors which works vice versa but no matter what the situation is, there is always some loss associated with the process [9]. The differences between the input power and output power are the loss that occurs inside it as stated by eq1.

$$\eta = \frac{P_{in} - P_{Losses}}{P_{in}} \times 100\% \quad (1)$$

These AC machines losses can be divided in four major categories such as the copper loss also stated as the I^2R loss, the core loss which is the hysteresis and eddy current loss, the mechanical losses due to the mechanical effect and finally the stray loss also known as the miscellaneous losses. Fig. 3 shows the design of AC generator.



Fig. 3 In-house Production of AC Generator

One of the most critical parts of an ac generator design is the insulation of its windings. If the insulation of a generator

breaks down, the machine shorts out. It is expensive to repair a generator when it has shorted. To prevent the windings insulation from breaking down as a result of overheating (which causes losses), it is necessary to limit the temperature of the windings. This can be partially done by providing cooling air circulation over them [9]. This is done to the AC generator shown in Fig. 3 to lower the heating of the windings and lowering the losses of the generator. This generator also has small Voltage regulation (VR) which is better in the sense that the voltage at the terminals of the generator is more constant with variation in load. This generator is also design to lower the friction of the shaft so to have a smooth rotation.

V. SENSORS

As discussed in topic III, the sensors plays a major part in this innovative invention, the sensors are separated into two parts, one is the temperature sensor and the other is the smoke sensors. These sensors are initialized in microcontroller step by step as stated in the flow chart in Fig 4.

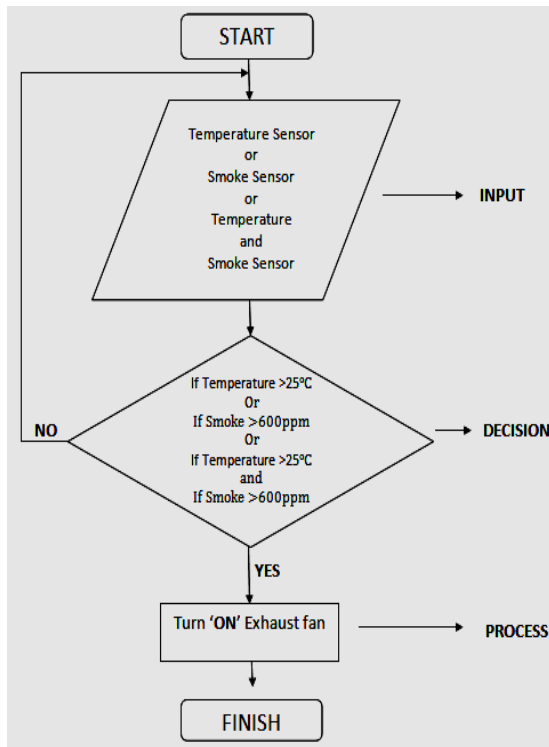

Fig. 4 Flow Chart of Microcontroller Programming

The implementation of one sensors may suffice but for instance although the smoke sensor provides rapid response time, it has high false-alarm rates [11, 12] and on the contrary the temperature sensor may provide reliable result but with a slow time response. In the case of a conventional fire detectors that use a single sensor, may either fail to activate when necessary or cause false alarms solely due to temperature changes. Therefore, even for a fire detector that uses a combination of the smoke sensor and the temperature sensor will not only provide better smoke sensor compensation but also provide a more intelligent fire alarm system [10]. The usage of two sensors could provide high sensitivity and

efficiency on the system. Fig. 5 shows the smoke and temperature sensor circuit connection. As the input (smoke /& temperature) is detected, the transistor turns ON and allows either or both relay switches to be ON which results to the exhaust fan motor being turned ON and suction occurs. Fig. 6 shows the sensors that are attached together with the ESSH.

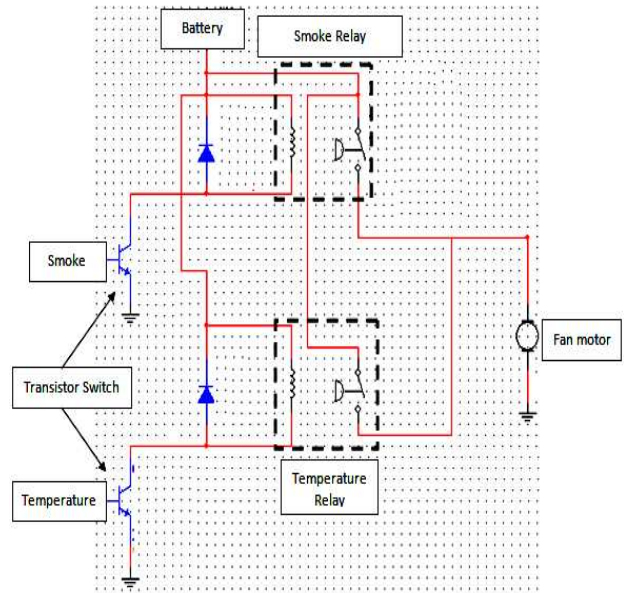

Fig. 5 Smoke and temperature Sensor Circuit

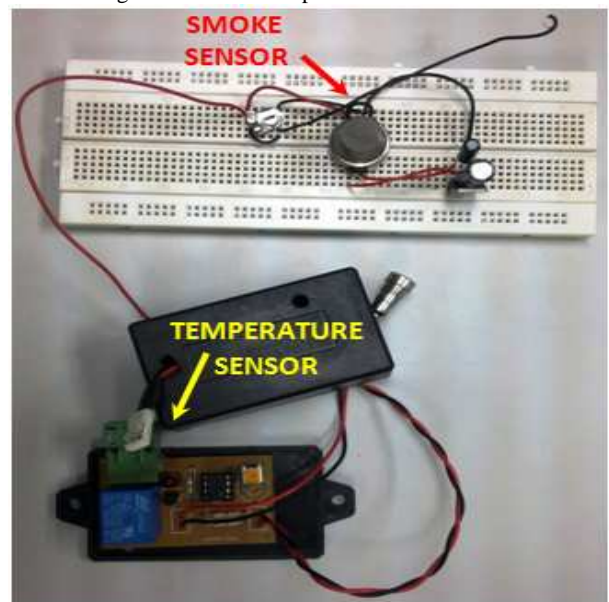

Fig. 6 Smoke and Temperature Sensor

VI. ACCEPTABLE INDOOR AIR QUALITY

Before this project is carried out, several criteria on air quality are to be followed according to the standards.

The Standards [13, 14, &15] to be considered is the:

- a) Humidity and Temperature
- b) Inadequate Ventilation
- c) Inside Contamination

- d) Outside Contamination
- e) Microbial Contamination
- f) New Building Materials

Based on this research the humidity and temperature is the only aspect considered and analyzed. According to [13], there is no “ideal” humidity level and temperature suitable for all building occupants. Many factors, such as personal activity and clothing may affect personal comfort. Acceptable relative humidity levels should range from 20 percent to 60 percent year-round [13]. Levels greater than 60 percent in the summer should be considered unacceptable [13]. Elevated relative humidity can promote the growth of mold, bacteria, and dust mites, which can aggravate allergies and asthma [13, 14, and 15].

Gas for instant carbon dioxide, is a normal element possibly from exhaled breath or other sources. Carbon dioxide is usually the conventional gas taken into account to measure the room humidity and temperature level. The outdoor carbon dioxide level ranges from 300-400 parts per million (ppm) [13, 14, and 15]. The level of this gas are usually greater inside a building than rather than outside which can reach up to 1000ppm. So due to the improper ventilation, it may cause headaches, fatigue and body irritation. It is suggested that carbon dioxide level should be at minimum 600-1000ppm, with average floor or building being less than 800ppm. Level exceeding 1000ppm may cause complains on air quality and therefore should be used as a guideline to improve ventilation. In this project, the air quality level(smoke) which is more than 600ppm will cause the exhaust fan to spins air off the room to produce comfortable level of air condition which is free from smoke and heat [13, 14, and 15]. Prototype model of the ESSH is shown in Fig. 7.



Fig. 7 Physical Model of Energy Saving Suction hood (ESSH)

VII. PERFORMANCE ANALYSIS OF ESSH

A. Energy Survey

Before analyzing the ESSH, Several aspects are considered such as the suction hoods usage whether in the industry or at home users. The data collected in Table I are for home users. Table I data shows a summary of an average cooking time per day in a house which is 6 hours. A CSH consumes minimum 80W of power to run the system, so an average of 480Wh energy is consumed. By month the CSH users will be using 14.4kWh and paying RM 3.14 for this system. Per annum they would be paying RM37.67 for the system that uses 172.8kWh. This amount is a lot for a Suction hood at home which some people may consider unnecessary luxury. Imagine that at a single purchase of the CSH can cause the consumers to have liability on their money in terms of paying extra on utility billing or maintenance for a system that is supposed to make life easy. The innovation of the ESSH considers this predicament aspect and is designed in a way not only to work as the conventional product, but also to save money and generate power so that it is applicable as a standalone system using this hybrid model. Table II shows the data obtain from the innovative idea of ESSH. Energy Survey Suction hood (Home Users).

SUCTION HOODS	
Estimate per meal cooking hours	2 hours
Average Meals per day 3 times (Breakfast, lunch, & Dinner)	6 hours
Power consume by the suction hood (Utilities)	80W
Total Energy usage 80W X 6hours	0.480kWh
Total Energy Usage per month 0.480kWh X 30	14.4kWh
Total Energy Usage per year 14.4kWh X 12	172.8 kWh
Utility Billing 14.4kWh X 21.8sen	RM 3.14/monthly RM 37.67/yearly
Power Source (ESSH) Generator	75W
Solar Panel	100W

B. ESSH Result

Table II shows the data obtained from the ESSH and is compared with the conventional product. This data is segregated into power consumes, power generated, energy saved, utility payment, and the estimated market price. Fig. 8 simplifies this data into the important aspect of this paper which is the power generated and energy saved. Both suction hoods are design to consume 80W of power to show a fair comparison to this experiment. The ESSH generates 175W

power with its hybrid model and saves up to 172.8kWh as mention before. This is obtained from the mechanical rotation of the exhaust fan that generates the generator plus the energy produced from the solar panel. The generator produces 75W of power as the exhaust fan spins and together with the solar panel which produces 100W of power. This amount is then loopback to the Exhaust fan's motor. Notice from Table II that the percentage different between the ESSH and CSH is 100% because of the novelty feature that the ESSH has.

TABLE II
ECONOMICAL SURVEY

	*ESSH	**CSH	SAVED	PERCENTAGE DIFFERENT
POWER CONSUME (EXHAUST FAN)	80W (Battery)	80W (Utility)	0	0%
POWER GENERATED (SOLAR + GENERATOR)	175 W	0 W	175W	100%
ENERGY SAVED (PER YEAR)	172.8kWh	0 kWh	172.8kWh	100%
UTILITY PAYMENT (PER YEAR)	RM 0.00	RM 37.67	RM 37.67	100%
ENERGY SAVED (W) (1000 UNIT)	172.8MWh	0kWh(Utility)	172.8MWh	100%
UTILITY PAYMENT (PER YEAR) (1000 UNIT)	RM 0.00	RM 37,670.00	RM 37,670.00	100%

*Energy Saving Suction hood (ESSH), **Conventional Suction hood (CSH)

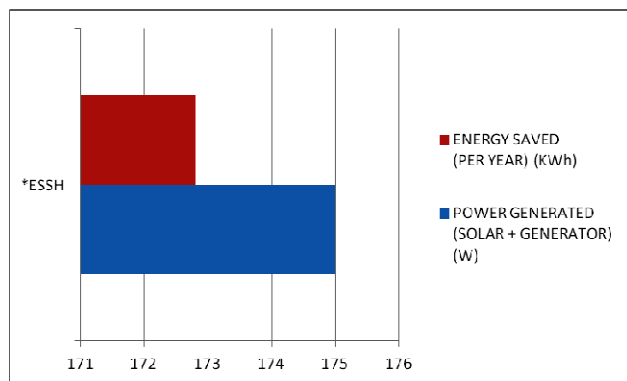

Fig. 8 Energy Saving and Generated

VIII. CONCLUSION

The innovation of this product is an attempt to create a standalone system which is free from any utility attachment. Even though this product shows emphasis on the Suction hood application, but the focused here are on the energy saving system and its innovation towards a loopback system by the usage of motor/generator, solar, sensors and batteries as source to power this system. In this study, an automatic kitchen suction hood named the energy saving suction hood (ESSH) was developed, implemented and investigated. The novel use of sensors to detect cooking contaminants and also a novel power loopback system was proposed. A comparison is made between the ESSH and the CSH and result shows that

the ESSH saves 172.8kWh/year of utility supply which is used by CSH. This amount of energy can save RM 3.14 from monthly utility bill and a total of RM 37.67 per year. In fact this product can generate 175 Watt of power from generator (75W) and solar panel(100W) that can be used either to supply other household appliances and/or to loop back to supply the fans motor. The innovation of this system is essential for future production of other equipment by using the loopback energy method and turning most equipment into a standalone system. The innovation of this system is essential for future production of other equipment by using the loopback energy method and turning most equipment into a standalone system.

ACKNOWLEDGMENT

The Author wish to thank the school of electrical Systems Engineering UniMAP as well as Electrical Energy and Industrial Electronics Systems (EEIES) research cluster for their technical support, also this work is supported by Fundamental Research Grant Scheme (FRGS) 2010/2011.

REFERENCES

- [1] Bhubaneswari Parida, S. Iniyar, Ranko Goic, "A review of solar photovoltaic technologies" Renewable and Sustainable Energy Reviews, Volume 15, Issue 3, April 2011, Pages 1625-1636
- [2] J-Kwon M, Nam K-H, Kwon B-H. Photovoltaic power conditioning system with line connection. IEEE Trans Ind Elec 2006; 53:1048e54.
- [3] Duryea S, Isalm S, Lawrance W. A battery management system for stand-alone photovoltaic energy systems. IEEE Ind Appl Mag 2001; 7:67e72.
- [4] Yu D, Yuvarajan S. Load sharing in a hybrid power source with a PV panel and PEM fuel-cell. Proc. Int. Conf. Applied Power Electronics; 2006. p. 1245e9.
- [5] Dali M, Belhadj J, Roboam X. Hybrid solarewind system with battery storage operating in grid-connected and standalone mode: control and energy management e experimental investigation. Energy 2010;35:2587e95.
- [6] Samson GT, Undeland TM, Ulleberg O, Vie PJS. Optimal load sharing strategy in a hybrid power system based on PV/fuel cell/battery/supercapacitor. Proc. Int. Conf. on Clean Electrical Power; 2009. p. 141e6.
- [7] Wang Peng-fei; Feng Tao; Liu Rong-hua; "Characteristics Study of the Swirl Air Curtain Exhaust Hood" 2010 4th International Conference on Bioinformatics and Biomedical Engineering (iCBBE), ICBBE.2010.55165942010, Page(s): 1 – 5.
- [8] Yung Ting; Gunawan, H.; Sugondo, A.; Kun-Lin Hsu; Jyh-Tong Teng; "Analysis and design of roof turbine ventilator for wind energy harvest", 2010 2nd International Conference on Mechanical and Electronics Engineering (ICMEE), Volume 2 ICMEE.2010.5558430, 2010, Page(s): V2-265 - V2-269
- [9] Chapman, S.J. (2005). *Electric machinery fundamentals* (4th ed). New York: McGraw-Hill.
- [10] Jimin Cheon, Jeonghwan Lee, Inhee Lee, Youngcheol Chae, Youngsin Yoo, Gunhee Han, "A Single-Chip CMOS Smoke and Temperature Sensor for an Intelligent Fire Detector" IEEE Sensors Journal, Vol. 9, August 2009, p914 - 921.
- [11] G. Jiang, F. Shang, F. Wang, X. Liu, and T. Qiu, "A combined intelligent fire detector with BP networks," in Proc. World Congr. Intell. Control Autom., Dalian, China, Jun. 2006, vol. 2, pp. 5417-5419.
- [12] S.-J. Chen, D. C. Hovde, K. A. Peterson, and A. W. Marshall, "Fire detection using smoke and gas sensors," Fire Safety J., vol. 42, no. 8, pp. 507-515, Nov. 2007.
- [13] Patt QUinn, Damon T. Arnold, "Illinois Department of Public Health: Environment Health Fact Sheet" Found at: http://www.idph.state.il.us/envhealth/factsheets/indoorairqualityguide_fs.htm.
- [14] Ventilation for Acceptable Indoor Air Quality (ASHRAE 62-2001)
- [15] Thermal Environmental Conditions for Human Occupancy (ASHRAE 55-2004).



Ismail Daut received his B. Applied Science in Electronic Industry from University of Science Malaysia in 1980, M.Sc in Electrical and Electromagnetic Engineering from University of Wales, College of Cardiff, United Kingdom in 1984 and PhD in Energy Conservation and Power Engineering from University of Wales, College of Cardiff, United Kingdom in 1991. His current research interest is towards renewable energy mainly in solar material, solar power and potential wind energy in Malaysia. He has authored and co-authored

more than 200 technical papers in the national, international journal and conferences. He is currently IEEE member.



Gomesh Nair received his B.Eng. (Hons) in Industrial Electronics Engineering and M.Sc in Electrical System Engineering from Universiti Malaysia Perlis in 2008 and 2010 respectively. In 2010, he joined the Department of Electrical System Engineering at University Malaysia Perlis as a lecturer. His areas of interest include Electrical Machine Design, Power Electronics, adjustable-speed drives, and energy conversion. He has authored and co-authored more than 20 technical papers in the national, international journal and conferences.



Muhammad Irwanto received his BEng from Medan Institute of Technology in 1998 and Master Degree in Electrical Power System from University of Gadjahmada, Jogjakarta, Indonesia in 2002. He is currently a lecturer in the School of Electrical System Engineering at University Malaysia Perlis (UniMAP). He is member of Electrical Energy and Industrial Electronic System Cluster, University Malaysia Perlis (UniMAP) Perlis, Malaysia. His research interest includes electrical power system

stability and renewable energy. He has authored and co-authored more than 40 technical papers in the national, international journal and conferences.



Mohd Irwan Yusoff received his B. Elect.Eng. (Hons) and MSc in Electrical System Engineering from University Malaysia Perlis in 2007 and 2010, respectively. In 2010, he joined the Department of Electrical System Engineering at University Malaysia Perlis as a lecturer. His areas of interest include power quality, adjustable-speed drives, energy conversion and power system applications. He has authored and co-authored more than 20 technical papers in the national, international journal and conferences.