

Intelligent Design of Reconfigurable Machines

Majid Tolouei-Rad

Abstract—This paper presents methodologies for developing an intelligent CAD system assisting in analysis and design of reconfigurable special machines. It describes a procedure for determining feasibility of utilizing these machines for a given part and presents a model for developing an intelligent CAD system. The system analyzes geometrical and topological information of the given part to determine possibility of the part being produced by reconfigurable special machines from a technical point of view. Also feasibility of the process from a economical point of view is analyzed. Then the system determines proper positioning of the part considering details of machining features and operations needed. This involves determination of operation types, cutting tools and the number of working stations needed. Upon completion of this stage the overall layout of the machine and machining equipment required are determined.

Keywords—CAD, Knowledge based system, Reconfigurable

I. INTRODUCTION

UTILIZATION of special purpose machine tools is the most economical way of producing very large quantities of similar parts. However, these machines are criticized for the lack of flexibility needed to respond today's competitive and rapidly changing market demands. In addition, despite incorporating high capital costs these machines become useless when the part in production is no longer needed. Consequently manufacturers often prefer utilization of conventional or CNC machines even for large production volumes. As a result, productivity is sacrificed for flexibility and a higher cost per part is achieved. Reconfigurable machines, a new generation of special purpose machines, can be considered as a valid solution to tackle this crucial problem. These are highly productive and relatively flexible providing an ideal option for large production volumes where limited flexibility is needed. Figure 1 shows a typical reconfigurable machine that performs drilling and tapping operations on a number of similar parts.

Reconfigurable machines make it possible to apply minor changes to the structure of the machine by repositioning machining units and accessories. This is extremely useful when there is a need for production change due to rapidly changing market demands. Even more, it is possible to totally disassemble the machine and re-assemble it in a completely new configuration to produce a different part. This becomes possible as the main components of the machine are mounted on the chassis by means of mechanical fasteners such as bolts and nuts. This provides these machines with great flexibility not seen in other types of machine tools. Reconfigurable machines equipped with advanced technologies have shown their

M. Tolouei-Rad is with School of Engineering, Edith Cowan University, Joondalup, WA 6027 Australia. (e-mail: m.rad@ecu.edu.au).

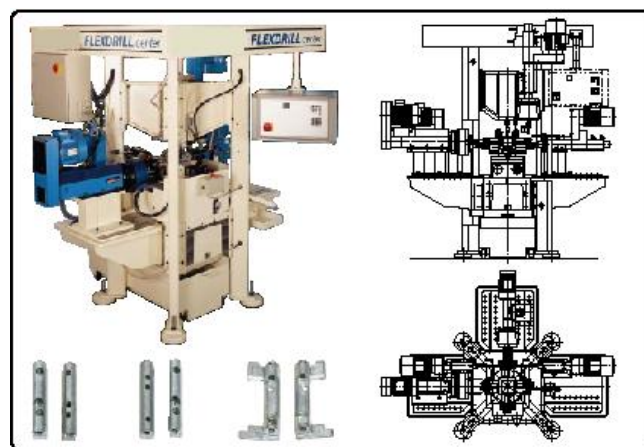

Fig. 1 A reconfigurable machine with parts produced [1].

remarkable efficiency in automation of production lines and machining processes with high qualities and quantities [2]. However, this technology has received little attention by contemporary researchers despite the huge profit it can make. Contributions on design and application of these machines are limited to those published by the author [3-4]. The shortage of skilled machine designers is also accountable for limited utilization of these machines that is not justifiable with the important role these can play in improving productivity.

Intelligent CAD systems have been extensively used to effectively tackle some real engineering problems in the three decades. Yet researchers explore new application areas for utilization of various artificial intelligence techniques. Knowledge-based expert systems (KBESs) proved to be effective for decision making when dealing qualitative information hard to capture in a computer program. Examples of application areas include design [4], process planning [5-6], design analysis [7], and NC programming [8]. Accordingly, this paper addresses a new application area for well-known KBESs: design of reconfigurable machines.

II. GENERAL STRUCTURE OF RECONFIGURABLE MACHINES

Heavy weight, rigid body, and inflexibility are of typical specifications of traditional special purpose machines. In contrast, reconfigurable machines are generally lighter and relatively flexible. The general structure of reconfigurable machines consist a number of machining and sliding units, and a part handling mechanism assembled together on a chassis. This is shown in Figure 1.

A. Chassis and Table

Chassis and table are very important components in these machines. On the basis of technical considerations of the machining operations required to make the given part and also machining properties of the part material, the table and chassis are properly designed or selected from a collection of standardized tables and chassis available. Due to high machining forces resulting from

machining operations the machine table and chassis should be sufficiently rigid to avoid vibration. All other components of the machine including machining and sliding units, and the part handling mechanism are mounted on the chassis and table by means of mechanical fasteners and special adjusting devices. Consequently, a reconfigurable machine could be conveniently assembled to form a modern special machine in minimal time for the specific production need.

B. Machining and Sliding Units

The units used in the reconfigurable machines are divided into two main categories: machining and sliding. Machining units equipped with an electro-motor revolve the spindle by means of pulley and belt systems in order to provide the rotational movement of the cutting tool. Like other machine tools, the connection of cutting tools to machining units is done by standard tool holders. Machining units are of three types: telescopic, power, and CNC. Telescopic units are used for light drilling and tapping operations as they also provide the spindle with a telescopic linear movement necessary for cutting tool penetration into the part. Both the linear and rotational movements necessary for performing drilling and tapping operations are provided simultaneously. Power units are used for milling and drilling operations where high cutting forces exist. Unlike telescopic units, power units lack the linear telescopic tool movement due to the existence of high cutting forces that may causing in telescopic movements. Consequently, these units are carried on sliding units providing them with necessary linear movements to penetrate into the part material. Figure 2 illustrates a telescopic and power-machining unit together with proper tool holders and cutting tools.



Fig. 2 Power unit (top) and telescopic unit (bottom) [1].

As shown in Figure 3, CNC machining units equipped with high quality servo-motors are also available for performing

drilling, tapping and milling operations precisely. CNC units can be programmed for very accurate machining operations when used in conjunction with a controller.



Fig. 3 A CNC machining unit with its controller [1].

Sliding units carry machining units and provide necessary feed movements for the cutting tool by means of hydraulic or pneumatic cylinders or servomotors. Adjustment of movement course is provided by micro-switches or mechanical systems. Figure 4 shows a pneumatic sliding unit with a mechanical course adjustment. The sliding plate that carries the machining unit is fastened to the connecting rod of the piston, and therefore, is capable of moving the cutting tool forward and backward.

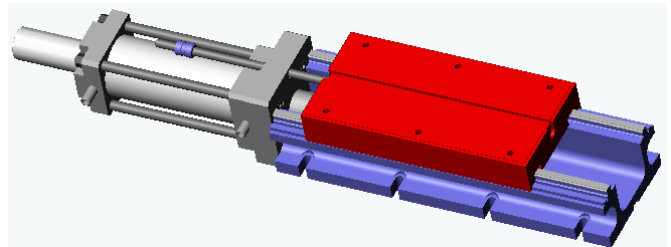

Fig. 4 Pneumatic sliding unit with course adjustment.



Fig. 5 CNC sliding units carrying machining units [1].

Depending on the nature of machining operation and cutting tool movement requirements, the machining unit can

be mounted on the sliding unit such the spindle axis is either along or perpendicular to the sliding direction. This is shown in Figure 5. As shown in the Figure, the sliding units can also be equipped with servomotors to make programmable CNC sliding units available for accurate movements.

III. SYSTEM ARCHTECTURE

The design of reconfigurable machines is a time-consuming process requiring expertise and an in-depth understanding of these machines and accessories. The use of KBES is considered as a proper solution to improve the efficiency of the design process of these machines. This is mainly due to the capability of these systems in (1) restoring qualitative knowledge, and, (2) integrating with databases containing quantitative information. Figure 6 shows general architecture of the system and its main components. It consists a user interface, KBES, CAD unit, feature recognizer, and the interface unit integrating all these components in a system.

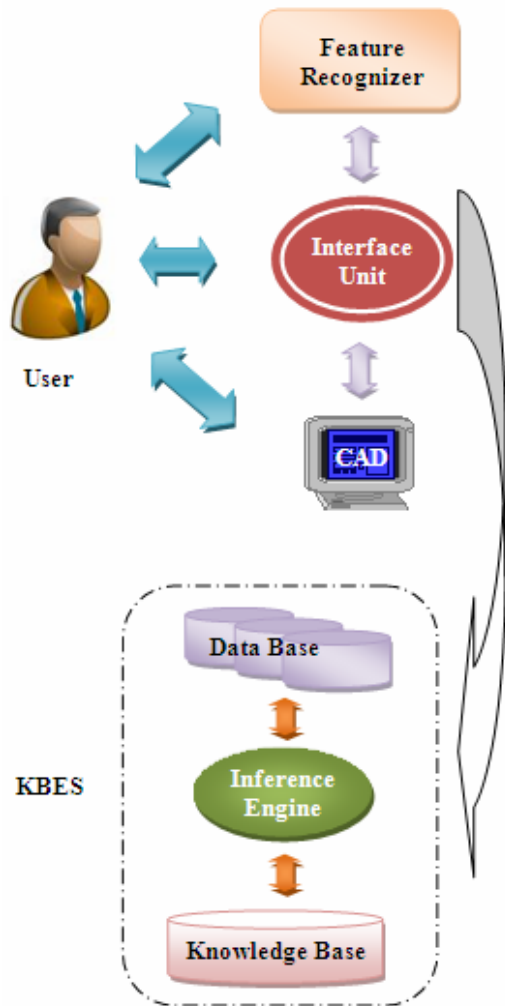

Fig. 6 General architecture of the system and its components.

A. Economic and Technical Analyses

The cost of utilizing reconfigurable machines is relatively high. Therefore, critical economic and technical justification of applying these machines should be made before any attempt is made to design and manufacture one. This includes a critical economical analysis of the part in question and its production characteristics; followed by a careful analysis of technical issues taking into consideration the types of machining operations required, the characteristics of the workpiece material, and the geometry of machining features. Both tasks are time-consuming and require a high level of expertise and experience, and unfortunately, there is a shortage of skilled people. As previously stated KBES have proven to be capable of processing both qualitative and quantitative information efficiently. Consequently, this approach has been considered as a potential solution to efficiently tackle this problem.

The KBES shown in Figure 6 assists the user in economic and technical evaluations of reconfigurable machines. It consists a knowledge base, a data base, and an inference engine. The knowledge specific to the domain of economical and technical analyses of the part for utilization of reconfigurable machines is represented in the form of IF-TEHN rules. The system restores input and output information of analysed parts in the data base for future use. Thus it adds to its existing knowledge. The inference engine actively uses the knowledge restored in the knowledge base to obtain the required parameters. The input to the system could be in the form of geometric and physical information of the part or in the form of group technology codes.

To analyse a part the inference engine first searches the data base to see whether the part in question has been processed in the past. If the part is defined using group technology codes then the system also searches for similar parts stored in the data base. If the part has been previously processed then the system uses the information restored in the data base. If a similar part is found then the information of the similar part is displayed. If the part is new part and has not been processed before, or if the operator decides to re-process a previously processed part then the inference engine fires appropriate rules on a forward chaining basis to determine the feasibility of utilizing a reconfigurable machine to produce it. In this case the system provides a cost per part comparison of two commonly used production methods (a) CNC machines or (2) reconfigurable machines. For the economical analysis, factors such as machining time, production volume, operators' wages, machine capital cost, amortisation cost, maintenance costs, cutting tool costs and overhead costs are considered to decide if reconfigurable machines provide a lower cost per part in comparison with other alternatives. It is also possible to include a cost computation when conventional machines are employed, although not used for quantity productions. After completion of economic analysis it should be decided whether or not to go ahead with the reconfiguration machine approach. If this approach is still of interest then a technical analysis should be carried out to investigate the feasibility of this method from a technical point of view. Factors such as

geometrical and topological information of the part, cutting tools, cutting forces, and material properties are all taken into consideration. In this paper it is not intended to provide detailed economical and technical analyses and interested reader is recommended to refer to another paper published by the author [3].

B. Feature Recognition

Upon confirmation of the feasibility of the utilizing the reconfigurable machines to produce the part from both economical and technical points of view, all of the machining features must be identified and appropriate cutting tools and parameters determined. Properly selection of cutting tools and machining parameters is of great importance in the success of any machining operation. The flowchart shown in Figure 7 illustrates different feature recognition steps. Currently this is limited only to the hole features. A 3D solid model of the part created by user or imported from another CAD system is made available to the system. A feature recognizer restored as a supplementary program interactively identifies existing holes on the part and determines the parent plane (or face) for each hole. Parent feature are considered as the faces to be machined to generate holes. The parent feature with most holes is chosen as current plane and the required drilling tip and parameters for machining each hole on this plane are assigned using the data restored in the data base. This process is repeated for other parent planes until all processed. For each feature identified proper cutting tools and machining parameters are automatically determined by firing appropriate rules in the knowledge base and also by use of the information of available cutting tools restored in the data base.

C. Selection of Machining and Sliding Units

Machining and sliding units are the most important components of reconfigurable machines that provide the cutting tool with rotational and linear movements necessary for cutting. Consequently, the selection of machining units, sliding units and accessories are performed such that the following two conditions are met. 1) Determined cutting tools are capable of making rotational and linear movements necessary for performing corresponding machining operations. 2) Appropriate machining parameters such as spindle speeds, feedrates, depth of cuts are provided for all the cutting tools. The selection of machining and sliding units is performed by the KBES using the information restored in the data base. This is only done after determination of cutting tools and machining parameters since the geometry of cutting tools and machining parameters dictate required powers, velocities, and required movements.

D. Machining Sequence Planning

Properly determination of machining operations and putting this operation in the right sequence is vital to successful design and manufacture of reconfigurable machines. A poor machining sequence plan leads to lower quality of production

and/ or increased machining times and consequently higher

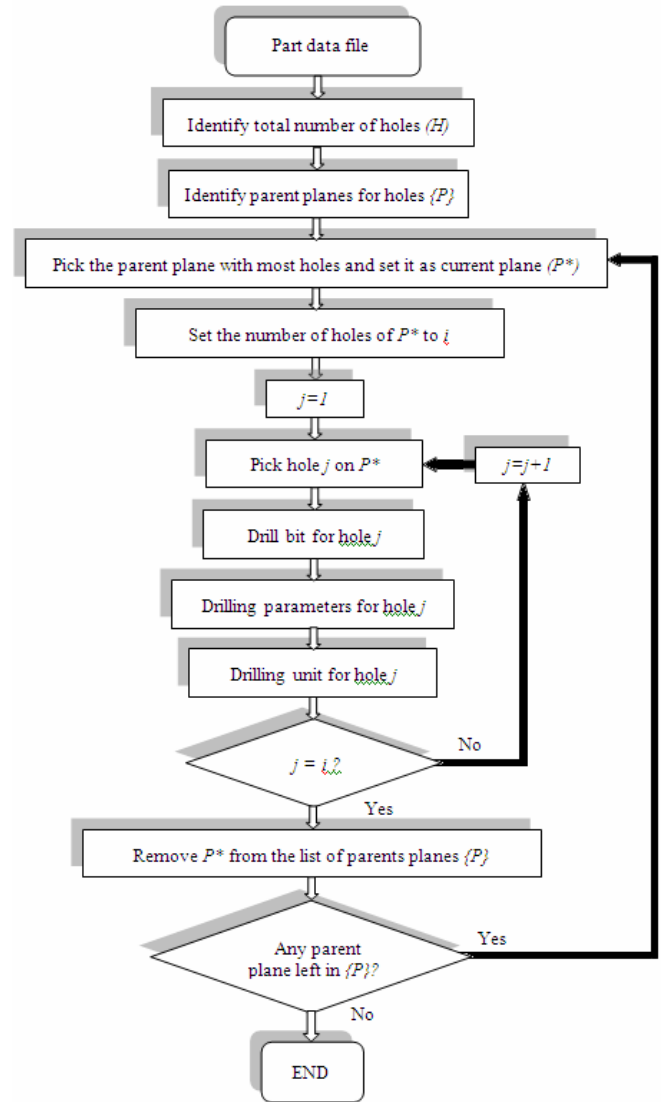

Fig. 7 Flow chart for feature recognition and determining cutting tools and parameters.

production costs. Often it is possible to combine and perform a number of operations in a single setup lowering machining times and costs. Indeed machining sequence planning determines the overall configuration of the machine and required machining units and accessories.

E. Machine Layout

Determination of machine layout can be considered as the most important step in the design process of reconfigurable machines. Failure to properly accomplishing this step leads to anything other than economic production. A poor layout determination may result in a machine design not responding to production needs and increased machining times and costs.

Generally two methods of single-station and multi-station layouts are used in design of reconfigurable machines. In the

first method, the part is in a fixed position on the machine table and is machined in a single machining setup. In the second method the part is repositioned from one station to the next until processed in all stations. The method chosen for a given part depends on specifications of the part and production. Generally a multi-station machine results in a higher production rate because of simultaneous machining of several parts in different stations.

To properly determine a layout for the reconfigurable machine the user consults with the KBES through the user interface module. The user enters the information of the part in the form of group technology codes and inputs required information such as part set-up and clamping method, part repositioning method preference if needed. In case of multiple working stations the part needs to be transferred from one working station by a linear motion provided by a sliding unit, or a rotational motion provided by an indexing table. Often when there are more than two working stations, a rotational movement using is preferred.

Upon processing this information the system retrieves an appropriate layout design from the data base. The layouts presented explicitly shows the number of working stations. The user may accept the presented layout design or request for another design to be provided. It is also possible for the user to modify the layout provided. In this case the result is assigned a new code and restored in the database for future use. On the basis of this layout the system assists designer in determining part set-up and clamping method, position and orientation of machining and sliding units, indexing table and all other accessories.

IV. CONCLUSIONS

Application of reconfigurable machines significantly improves machining productivity in comparison with other production alternatives. Reconfigurability of these machines make them quite useful in responding to rapidly changing market demands, feature not seen in traditional special machine tools. These machines can be altered or disassembled and then reassembled in a different configuration to produce a different part. However, due to shortage of skilled designers these machines are not used very often. The system described here greatly assists designers in properly economical and technical analyses of the utilization of these machines and in determining required cutting tools and parameters, and finally determining appropriate machine layout for producing the part needed. This is of great importance as it lowers the level of expertise needed and significantly reduces the machine design time. The system described here is limited to drilling operations and more work is needed to cover other machining operations. However, a similar approach could be used to cover other operations.

REFERENCES

- [1] Suhner Corporation General catalogue, "Automation Expert," Switzerland, 2001.
- [2] M.P. Groover, "Automation, Production Systems, and Computer Integrated Manufacturing," Prentice Hall, NJ, USA, 2008.
- [3] M. Tolouei-Rad, and S. Zolfaghari, "Productivity improvement using Special-Purpose Modular machine tools," *Int. J. Manufacturing Research*, Vol. 4, No. 2, pp. 219-235, 2009.
- [4] M. Tolouei-Rad and S. M. Tabatabaei, "Design and manufacture of modular special purpose machine tools," Design and manufacture of modular special purpose machine tools, *Int. Conf. on Achievements in*

Mechanics, Manufacturing and Materials Science, 6-9 Dec., Giliwice-Zakopane, Poland, 2005.

- [5] S. Myung and S. Han, "Knowledge-based parametric design of mechanical products based on configuration design method," *Expert Systems with Applications*, Vol. 21, Issue 2, pp. 99-107, 2001.
- [6] S. C. Park, "Knowledge capturing methodology in process planning," *Computer-Aided Design*, Vol. 35, Issue 12, October 2003, pp. 1109-1117, 2003.
- [7] L. Patil and S. S. Pande, "An intelligent feature process planning system for prismatic parts," *International Journal of Production Research*, Vol. 40, No. 17, pp. 4431-4447, 2002.
- [8] M. Novak, and B. Dolšaka, "Intelligent FEA-based design improvement," *Engineering Applications of Artificial Intelligence*, Vol. 21, Issue 8, pp. 1239-1254, 2008.
- [9] M. Tolouei-Rad and G. Payeganeh "A hybrid approach for automatic generating of NC programs," *Journal of Achievements in Materials and Manufacturing Engineering*, Vol. 14, No. 1 & 2, pp. 83-89, 2006.

Majid Tolouei-Rad is a Senior Lecturer at School of Engineering, Edith Cowan University in Perth, Australia. He received his PhD in Mechanical Engineering from the University of South Australia in 1997. Since then he has been extensively involved in tertiary teaching and research and supervising research students. He has worked as a Consulting Engineer for Industries and a Professor for Reputable Universities in Iran, Canada and Australia. His research interests include computer-integrated manufacturing, robotics and automation, materials and manufacturing.