

The Frame Analysis and Testing for Student Formula

Tanawat Limwathanagura, Chartree Sithananun, Teekayu Limchamroom, Thanyarat Singhanart

Abstract—The objective of this paper is to study the analysis and testing for determining the torsional stiffness of the student formula's space frame. From past study, the space frame for Chulalongkorn University Student Formula team used in 2011 TSAE Auto Challenge Student Formula in Thailand was designed by considering required mass and torsional stiffness based on the numerical method and experimental method. The numerical result was compared with the experimental results to verify the torsional stiffness of the space frame. It can be seen from the large error of torsional stiffness of 2011 frame that the experimental result can not verify by the numerical analysis due to the different between the numerical model and experimental setting. In this paper, the numerical analysis and experiment of the same 2011 frame model is performed by improving the model setting. The improvement of both numerical analysis and experiment are discussed to confirm that the models from both methods are same. After the frame was analyzed and tested, the results are compared to verify the torsional stiffness of the frame. It can be concluded that the improved analysis and experiments can be used to verify the torsional stiffness of the space frame.

Keywords—Space Frame, Student Formula, Torsional Stiffness, TSAE Auto Challenge

I. INTRODUCTION

TSAE Auto Challenge Student Formula [1] is the student formula competition of Thailand under formula SAE international rules [2] organized by society of engineers Thailand. In order to participate in this competition, the formula car was formulated by considering many parts using the engineering skills. The frame is one of the most important parts that integrated the other parts together. The best frame is the frame with less mass but still have high torsional rigidity. To design frame, the analysis of torsional stiffness of the frame and verify this results by using the torsional stiffness test became more important [3]–[5].

There are many types of frame been used in Student Formula Competition for example: Space Frame, Monocoque, and Ladder Frame [6], [7]. A space frame, as shown in Fig. 1, is a truss-like, lightweight rigid structure constructed from interlocking struts in a geometric pattern. Space frames are a series of tubes which are joined together to form a structure that connects all of the necessary components together. Space frame is simple and cheap when compared to the other twos. Therefore it can be seen commonly in student level competition.

Tanawat Limwathanagura, Chartree Sithananun, and Teekayu Limchamroom are with the Automotive Design and Manufacturing Engineering, Chulalongkorn University, Phayathai, Pathumwan, Bangkok, 10330, Thailand.

Thanyarat Singhanart is with the Departments of Mechanical Engineering, Chulalongkorn University, Phayathai, Pathumwan, Bangkok, 10330, Thailand (e-mail: fmetsn@eng.chula.ac.th).



Fig. 1 Space frame

In advance level of racing, Monocoque, as shown in Fig. 2, is more popular. Monocoque is a construction technique that supports structural load by using an object's exterior. It is generally made as one piece. The use of composite materials in monocoque skins allows strength, stiffness and flexibility to be controlled in different directions. With the used of composite material, Monocoque are significantly higher in cost but the performance is worth investing. The last one isn't much seen, it is the ladder frame. The ladder frame is a shorthand description of a twin-rail chassis. It is typically made from round or rectangular tubing similar to space frame. Ladder frame can use straight or curved members, connected by two or more cross members. Body mounts are usually integral outriggers from the main rails, and suspension points can be well or poorly integrated into the basic design.

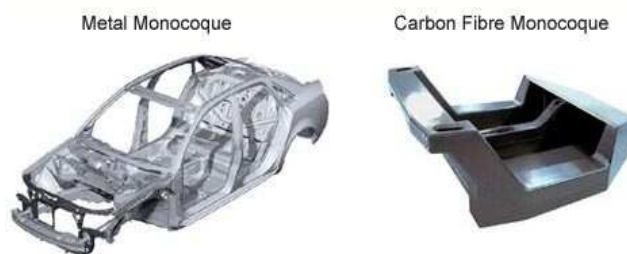

Fig. 2 Monocoque

The space frame was chosen for 2011 Auto Challenge Student Formula. From previous research [5], the torsional stiffness of the 2011 frame was designed by considering required mass and torsional stiffness with the usage of the numerical and experimental methods. The numerical result of

torsional stiffness was verified by using experiment. It can be seen that the error between numerical result and experimental result is large due to many mistakes when setting the experiments. In this paper, the improvement of the numerical model and experiment is the interested topic that has to be carefully considered. Therefore, the objective of this paper is to study the analysis and testing for determining the torsional stiffness of the student formula's space frame.

II. THE ANALYSIS AND EXPERIMENT OF 2011 FRAME [5]

The 2011 frame of Chulalongkorn University team for 2011 Auto Challenge Student Formula is shown in Fig. 3. The frame was designed under SAE international rules with many concepts such as

- 1) Lower the center of gravity by using the curve beam
- 2) Use the triangular mesh at the rear to improve the torsional stiffness of the frame
- 3) Use removable member at the end to provide the space for attaching the engine, etc.

Additionally, the frame was designed under the requirements of mass less than 30kg and torsional stiffness of the whole car more than 1200Nm/deg.

The Model for FEM analysis is shown in Fig. 4. The frame is fixed at one end and the torque is applied at the other end. From Fig. 4, the deflections at point 1, 2, 3, and 4, which located at the rear part of the frame, are determined when fixed at the front. The analysis was also performed when fixed at the rear and torque is applied at the front to determine the deflections at point 5, 6, 7, and 8, which located at the front part of the frame. The torsional stiffness of the frame is from the lowest value which occurred from point 7 when fixed at the rear. The torsional stiffness from numerical analysis is found to be 1270Nm/deg.



Fig. 3 The 2011 frame for 2011-2012 Auto Challenge student formula

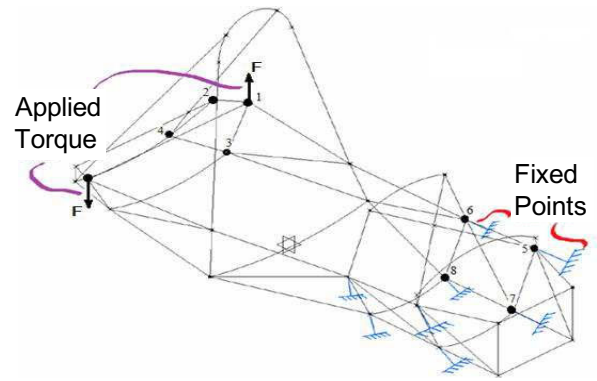

Fig. 4 Model for FEM analysis

The torsional stiffness test was performed as shown in Fig. 5 and 6. The steel rod is used to connect to the eight points at the front which can be considered to be fixed end. At the other end, the frame is connected to the steel beam that lied on the pivot point. The load is applied at one end of the steel bar and produced the torque to the frame as shown in Fig. 7. The torque applied on the frame can be determined from

$$T = mgL = (F_1 + F_2)w \quad (1)$$

Where m is the end mass and L is the distance between end mass and pivot point.

The deflections of point 1, 2, 3, and 4 as shown in Fig. 4 are collected corresponding to the increasing load. The deflections of point 5, 6, 7, and 8 can be determined with the rear part fixed and torque applied to the front. The angle of rotation as shown in Fig. 8 can be calculated from

$$\theta = \tan^{-1} \frac{a-b}{L} \quad (2)$$

The torsional stiffness from experiment can be determined from $K = T/\theta$. The experimental results show that the torsional stiffness of the frame is 787Nm/deg. By comparing the numerical and experimental results, the error is found to be 38.0% which is considered to be large.

The errors may come from many parts that will be discussed in next section. After the source of error is identify, the improvement of the experiments and numerical analysis can be clearly obtained.

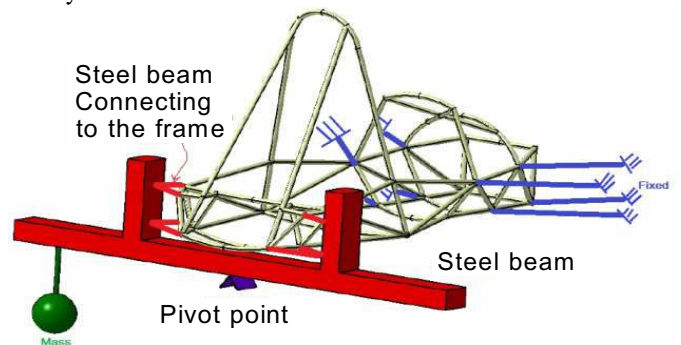
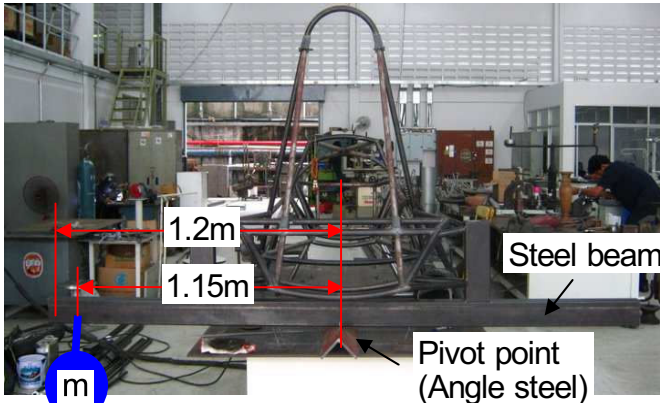

Fig. 5 Model for experiment setup



(a)



(b)

Fig. 6 Experimental setup for torsional stiffness tests

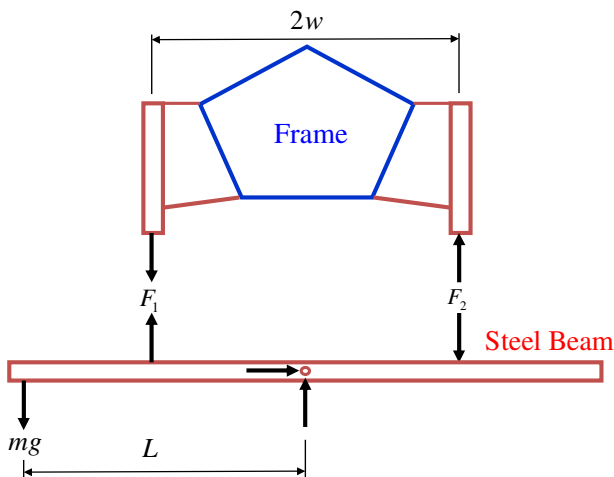

Fig. 7 Free body diagram of separated frame and steel beam

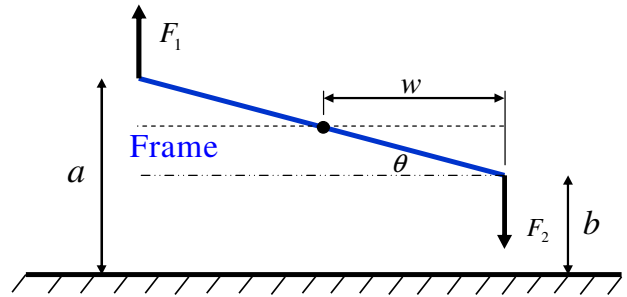

Fig. 8 The angle of twist

III. THE DISCUSSION ON THE PAST RESEARCH

In the experiment, the connection points between the test rig and the frame at the rear are joined by welding two steel columns to the frame as shown in Fig. 5 or 6(a). It can ensure the lock between the frame and the test rig however, caused by welding these two members, the two part acting like one body. As the result of this action, the point where load was distributed into the frame has much error and fails to simulate the driven condition. The process of holding the frame where the loads will be applied should be improved to gain better result for the torsional stiffness.

As can see in Fig. 5 and 6(a), the front part was fixed by welding eight rods to frame. The torque applied will cause the frame integrated with eight rods to rotate, then if the angle of twist is calculated from the absolute deflections at the rear, this value will represent the angle of twist of the whole system but not only the frame. To ensure that only the frame rotates with fixed support at the front, the improvement of the fixed points has to be considered. It would be more accurate to ensure that the fixed parts don't have any movement. The deflection at the fixed part must be measured and subtracted from the deflection at the rotating end to get the displacement from frame rotation only. Also, in measuring the deflection, suitable equipment should be selected to measure distance a and b .

IV. THE IMPROVED ANALYSIS

In the finite element analysis the method for applying load is changed as shown in Fig. 9. The force was distributed equally into all four point of the frame on each side (point 1, 2, 3, 4) when the rear was fixed at point 5, 6, 7, and 8. This model verifies the condition to be the most related to the real experiment.

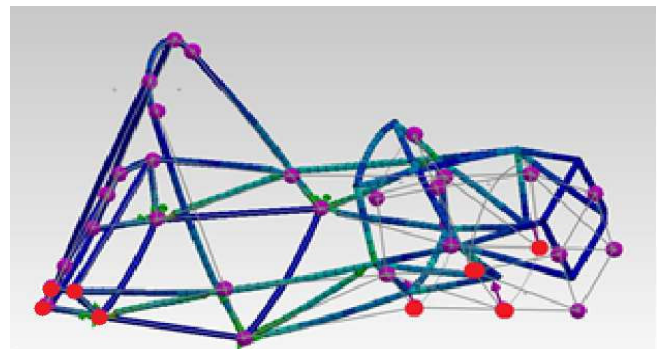

Fig. 9 The improve analysis (The red points are the applied load points while the purple are the construction points)

V. THE IMPROVED EXPERIMENT

For improving of the experiment first of all the way to connect the frame and the test rig was changed. Instead of welding the frame and the test rig together by a steel beam or steel rods, new propose was introduced. In order to simulate the closed situation in real driving, the force should distribute through the frame passed by the wheel. Therefore not only the frame, A-arms and wheel base were attached to the frame as shown in Fig. 10. The new test rig is designed by connecting the wheel base both at the front and at the rear to the test rig.

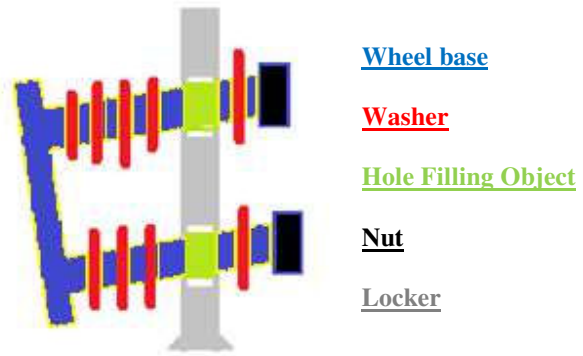

Fig. 10 The new test rig

This new test rig can be locked with wheel base by combination of nuts and washers as shown in Fig. 11(a) and 11(b). The hold fitting object (Green part) minimize the clearance between the hold and the wheel base. Due to the inclination of the wheel base (Blue part) the different numbers of washer (Red part) were added. Therefore the locker is possible to position vertically with the test rig. After that washers and nuts (Black part) are used to lock at the outer side. This ensures the limitation of vertical movement and don't allow the locker to slip out. One thing to consider is the number of washer used. Washer usage is depending on how the wheel base aligned with respect to the test rig. The front part of the test rig can freely rotate by using the pin support as can see in Fig. 11(a).



(a) The locker



(b) Side view of the locker
 Fig. 11 Locker setting

For more accuracy of the experiment result the dial gauge and vernier height gauge are used to measure deflection at the fixed end and at the rotating end, respectively. The dial gauges with 0-25.0mm / 1.0" range and resolution 0.03mm/0.0012" are used to measure the deflection at the fixed end. At the rotating end the vernier height gauge will be installed to observe the deflection at both sides. Actually dial gauges are used for checking whether the fixed part has movement or not, if there is the measurement gained, it will be subtracted from the rotating end to ensure the exact displacement.

VI. RESULTS

The model when fixed at the front and the torque applied at the rear was performed and the result from point 7 is used to compare with past experiment as shown in Table I. The improved experimental results for point 1, 2, 3, 4, 5, 6, 7, and 8 can be found to be 1371, 1104, 1251, 1060, 1143, 1483, 955, and 1122, respectively. The results from the torsional stiffness test and FEM analysis are presented in Table II. With these two values of torsional stiffness the percentage of error can be determined.

VII. DISCUSSION

From the previous experiment the error between the FEM analysis and the experiment was 38.0% which is considered being unacceptable and failing to verify the numerical result. With the improvement presented in this paper, the result from the improvement version has acceptable error between the FEM analysis and the experiment. It shows a good way of improving and proves that the improving of the analytical model and experimental setting significantly affect the result. Therefore, the numerical result is verified and can be used in design process. However some change could be made to achieve more and make both FEM analysis and exact test more precise.

FEM analysis can be used to predict the torsional stiffness in order to design the new frame. The torsional stiffness of the candidate frames based on the FEM analysis are compared and selected for the best performance frame. However the exact torsional stiffness test is required for the final frame design anyway.

VIII. CONCLUSIONS

The improved analysis and experiment are presented and discussed in this paper. It can be seen that this improvement has succeeded to model the real situation of load applied to the frame that can be seen from the small error between analytical and experimental results. From now FEM analysis can be used as an effective tool for designing a frame.

However lots of improvements are expected to be done in order to enhance it to the next level. More designs are possible to help improving this test rig to become more accurate and flexible.

TABLE I
 COMPARISON BETWEEN IMPROVED AND PREVIOUS RESULTS

	Torsional Stiffness [Nm/deg]		Comparison
	FEM	Experiment	
Previous Experiment	1270	780	38.0%
Improved Experiment	1006	955	5.3%

TABLE II
 IMPROVED TORSIONAL STIFFNESS FROM POINT 1-8

Point	Torsional Stiffness[Nm/deg]		Comparison
	FEM	Experiment	
1	1371	1427	4.1%
2	1104	1157	4.8%
3	1251	1329	6.2%
4	1060	1129	6.5%
5	1143	1209	5.8%
6	1483	1547	4.3%
7	955	1006	5.3%
8	1122	1165	3.9%

REFERENCES

- [1] "Auto Challenge Student Formula", Available at www.tsae.or.th/autochallenge.html, Accessed on 20, Mar 2012
- [2] "Student Formula Rules and Regulations 2011", Available at <http://www.jsae.or.jp/formula/en/background.html>, Accessed on 20, Mar 2012
- [3] Abrams, R., "Formula SAE Race Car Analysis: Simulation & Testing of the Engine as a Structural Member", in *FISITA 2008 World Automotive Congress*, Munich, Germany, 2008
- [4] William B. Riley and Albert R. George, "Design, Analysis and Testing of a Formula SAE Car Chassis", in *SAE International, Proceedings of the 2002 SAE Motorsports Engineering Conference and Exhibition*, Indianapolis, Indiana, 2002
- [5] Sithananun C., Leelaphongprasut C., Baitiang C., Rungpipatphol N., Noomwongs N., Singhanart T., "SAE Student Formula Space Frame Design and Fabrication", in *The second TSME International Conference on Mechanical Engineering*, Krabi, Thailand, 2011
- [6] Edmund, F. Gaffney III and Anthony, R. Salinas, "Introduction to Formula SAE® Suspension and Frame Design", *SAE International*, 1997
- [7] "Why Our Chassis Looks the Way It Does", Available at: <http://www.erareplicas.com/misc/stress/deslogic.html>, Accessed on 20, Mar 2012