

# Design of Modular Robotic Joints for Achieving Various Robot Configurations

Majid Tolouei-Rad, and Anurag Dhull

**Abstract**—This paper describes various stages of design and prototyping of a modular robot for use in various industrial applications. The major goal of current research has been to design and make different robotic joints at low cost capable of being assembled together in any given order for achieving various robot configurations. Five different types of joints were designed and manufactured where extensive research has been carried out on the design of each joint in order to achieve optimal strength, size, modularity, and price. This paper presents various stages of research and development undertaken to engineer these joints that include material selection, manufacturing, and strength analysis. The outcome of this research addresses the birth of a new generation of modular industrial robots with a wider range of applications and greater efficiency.

**Keywords**—Actuator, control system, configuration, robot.

## I. INTRODUCTION

ROBOTICS is a diverse and promising field with numerous opportunities and challenges. For a very long time man has dreamt of mechanical slaves of great strength which could carry out wonderful tasks for him. The story of Aladdin and the Wonderful Lamp is popular throughout the world. When the lamp was rubbed, a genie appeared and carried out the wishes at a command. While this story expresses the benefits of having such a wonderful mechanical slave, it also points out the danger of such a powerful device falling into evil hands. Today robots fulfill these wishes. For example, the Defense Advanced Research Projects Agency (DARPA), a division of the United States Department of Defense, has sponsored two autonomous robotics competitions with one million to two million dollar prizes in order to support robotics research and development [1]. iRobot's Roomba, an autonomous vacuum, has successfully made robotics available to the consumers, selling over two million units as of January 2008 [2].

Currently, there are five common configurations of industrial robots that are widely used. These are elbow, cylindrical, spherical, SCARA, and Cartesian. Each has a fixed overall configuration for certain applications. Obviously this puts a limit on the range of applications for each robot configuration. Therefore it would be beneficial and highly desirable to make robots that are capable of being converted from one configuration to another in order to serve multiple functions. The idea is similar to the "Transformers" film [3]

Majid Tolouei-Rad is a senior lecturer of the School of Engineering, Edith Cowan University, Perth, Western Australia (e-mail: m.rad@ecu.edu.au).

Anurag Dhull is a mechanical engineering student at the School of Engineering, Edith Cowan University, Perth, Western Australia.

where robots can adapt various configurations making it possible to get transformed into various shapes with different capabilities. Research on modular robot is a hotspot in the robot field. Attempts have been made to design modular robots to increase the range of applications and some progress has been made. For instance, Xuan et al. [4] developed seven kinds of modularizing methods and three kinds of configuring methods to design modular robots. They used a bottom-up approach to achieve the goal of rapid response. However, the idea faced limitations and is not widely used. It is perhaps fair to say that industries could be more flexible and more responsive to fluctuating market demands if the philosophy of modularity is further developed and used in design and manufacture of industrial robots.

## II. ROBOTIC JOINTS AND LINKS

A joint of an industrial robot provides relative motion between two links, and often, only one degree-of-freedom is associated with each joint. Connected to each joint are input link and output links. Links are the rigid components of the robot manipulator. The purpose of the joint is to provide controlled relative movement between the input link and the output link. Industrial robots are often mounted on a fixed base on the floor as shown in Fig. 1. The base is connected to the first joint. It is the input link to the first joint, the first in the series of joints used in the construction of the robot. The output link of this joint is the input link to the next joint, whose output link is also the input link to another joint.

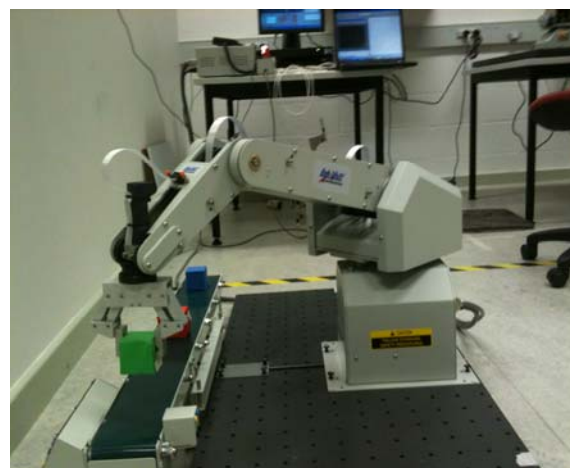

Fig. 1 An elbow industrial robot in action where its joints and links are visible [5]

Most of industrial robots have mechanical joints that can be classified into one of five types: two types that provide translational motion and three types that provide rotary

motion. These joint types are illustrated in Fig. 2 and are based on a scheme described in [6].

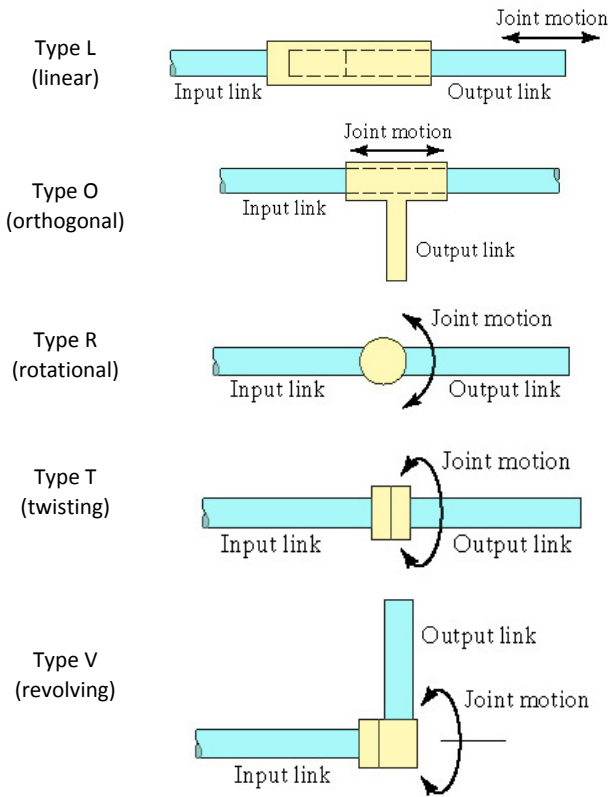

Fig. 2 Five types of joints commonly used for industrial robots [7]

Each of these joint types has a range over which it can be moved. The range for a translational joint is usually less than a meter, but for large gantry robots, the range may be several meters. The three types of rotary joints may have a range as small as a few degrees or as large as several complete turns [7].

### III. MODULARITY

Modularity can be defined as a product that has been designed with standardized units or dimensions, as for easy assembly and repair or flexible arrangement and use. The ability to create motion gives robotic joints the potential for modular development that would be useful in a variety of applications. For a part to be modular, it must be an individual working unit, but able to interface with a variety of other parts and systems to create a more complex machine. Modularity allows for versatility in design and machine capabilities, the ability to adapt according to the needs of the user, and ease of assembly [8]. Mechanically, a part would need to be able to attach to other parts or surfaces using common materials, such as clamps or bolts. Electronically, it would need to be able to plug into a standard power source, battery, or outlet. In the case of a robotic joint, it would also need to be able to transfer both electrical power and

communication signals to another part or joint [9]. In order for a joint to be modular and be commercially viable, some challenges must be overcome and criteria must be met. A feasible design would have to:

- have properties comparable to commercially available joints, such as torque capabilities and power requirements;
- keep price per unit below industry standards;
- be capable of transferring power, either electrical or mechanical, as well as data; and
- rotate about one or more axes.

There are currently many robot kits available that allow for motor and component reconfiguration; however, their basic abilities hinder their capacity to be used in professional applications. High quality modular joints are often packaged in manipulators, such as arms, consisting of five or more joints. This becomes an issue if a user only has a need for two joints, yet they must purchase the entire kit of five joints. With a modular joint a user can obtain only the joints they need, which cuts back on both the cost and complexity of any robotic applications.

One of the predominant challenges in this project is to find a balance between joint capabilities and cost. Currently there is a gap in the market for a midrange robotic joint. Successful high load joints are capable of lifting several kilograms and are produced by major manufacturers such as Fanuc and Mitsubishi, but there is a cost increase of several thousand dollars. However, in this project the objective has been to keep the costs low so there has been a need to design low cost robotic joints can perform similar to more expensive ones. The first step in achieving this objective has been to minimize the cost of each individual part. Precision and durability are often lost when cheaper components are used so compromise needed to be made. Another way to reduce component cost is to construct robotic joints using common and readily available parts. Customized parts are typically more expensive than mass produced or commonly stocked items. Since this research focused on developing low cost joints, all aspects of the design were affected by some limitation. This would require all aspects of the joint to be efficient and thoroughly researched in order to ensure that a balance between price and technical ability is maintained.

### IV. THE RESEARCH OBJECTIVE

The objective of this research has been to develop, manufacture, test, and evaluate modular joints that meet required design specifications and capabilities and are cost effective. The following steps are taken in order to achieve this objective:

1. Assessing the requirements of each joint and developing a series of task specifications.
2. Designing each joint based on the task specifications

3. Testing each joint design for evaluating:
  - a. durability of the joint and identifying the environment where it can work safely;
  - b. life time analysis or determining how long it can work without any failure;
  - c. determine the maximum weight it can safely lift;
  - d. how fast, accurate, and precise each joint can move.
4. Improving the design based on the test results.

Extensive research has been carried out on the analysis of various mechanical structures of robotic joints and electromechanical actuators which are capable of being controlled with required accuracy and precision. In addition, all of these joints should be modular and able to get connected in a variety of configurations, and yet the resultant cost of manufacturing these joints should stay within limit.

A successful joint design would be the one which is able to get connected to multiple modules while maintaining communication and efficient power and torque transmission. In addition, the prototype must be able to withstand in action stresses in any arbitrary plane, since any number of joints could be connected in different configurations. Lastly, the robotic joint modules must be commercially viable. By creating a truly modular joint, these mechanisms would be an affordable option to implement in a great range of industrial applications.

#### V. DESIGN SPECIFICATIONS

Certain task specifications were identified to ensure that robotic joint designs meet the requirements established in the problem statement. These specifications were then quantified using an importance index developed ranging from 0 to 10 where 0 represented the least important and 10 the absolutely essential one. Use of the importance index allowed for easy design comparisons and determination of project progress. Those specifications that were identified as most important included cost, modularity, actuation, and safety. These specifications related directly to the requirements described in the problem statement, and thus were essential elements of the robotic joint design. Safety was critical, as a lack of safety could result in serious legal and health issues. Specifications that were recognized as important to consider during brain storming stage and design of the joints included durability, easy maintenance, materials requirements, manufacturability, ease of operation, power requirements, applications areas, precision and dimensional accuracy.

A challenging design would make it possible to create a single joint with multiple degrees of freedom, or being able to move in more than one axis. Utilizing a series of modular joints allow for the same, if not greater, degree of freedom while reducing the complexity of the design of individual joints. However, including modular characteristics in the design may cause challenges such as difficulties in proper controlling of individual joints working simultaneously, and

assuring mechanical strength of mechanical connection between the joints. The communication between modules was also another challenging task in this project. For an acceptable performance of a modular robot all of the joint modules must be able to properly communicate with the controller.

#### VI. DESIGN AND MANUFACTURING OF JOINT PROTOTYPES

All the joints were designed in a 3D modeling environment by use of powerful CAD design software, SolidWorks. All the dimensions were finalized and interferences were detected and resolved in the design stage. Then the mechanisms were subjected to animation of the motion to verify the validity of the design and necessary revisions were made. In addition, each part has been subjected to finite element analysis for analysis of the strength and durability in actual working conditions. The design of each joint member has been revised according to the results of the test. Fig. 3 shows one of the joint members when it is modeled in the finite element analysis software.

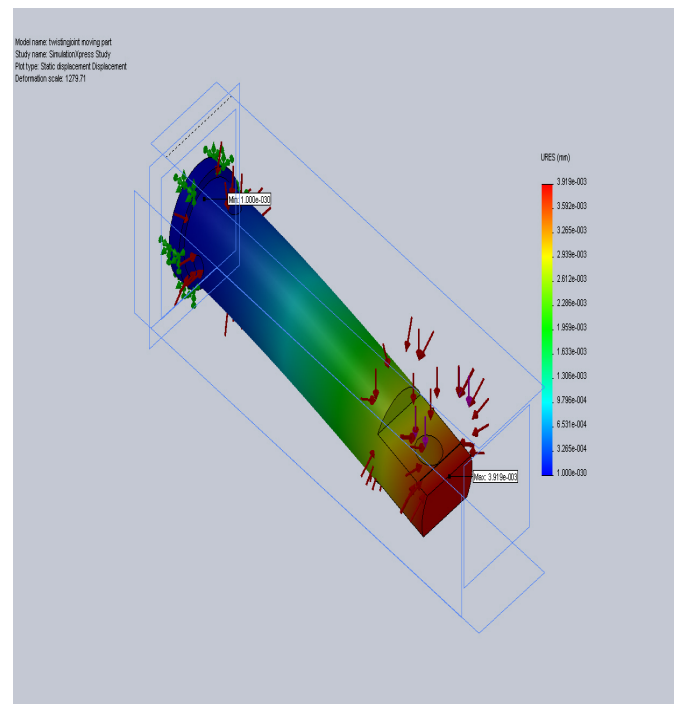
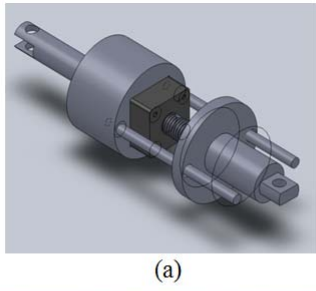

Fig. 3 A joint component under analysis by the finite element analysis method

Figs. 4 to 8 show the 3D models of each joint, along with its manufactured prototype. The five joint manufactured are:

1. Linear or type L joint as shown in Fig. 4. The relative movement between the input link and the output link is a translational sliding motion, with the axes of two links parallel.



(a)



(b)

Fig. 4 (a) 3D model and (b) manufactured prototype of linear (type L) joint

2. Orthogonal or type O joint as shown in Fig. 5. This is also a translational sliding motion, but the input and output links are perpendicular to each other during the move.

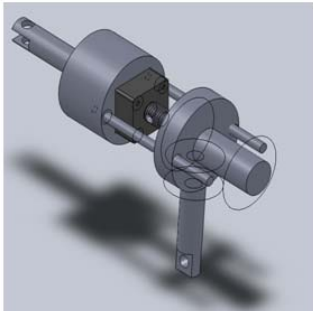

(a)



(b)

Fig. 5 (a) 3D model and (b) manufactured prototype of orthogonal (type O) joint

3. Rotational or type R joint as shown in Fig. 6. This type provides rotational relative motion.

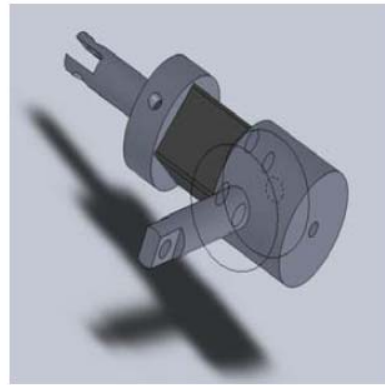

(a)



(b)

Fig. 6 (a) 3D CAD model and (b) the manufactured prototype of rotational (type R) joint

4. Twisting or type T joint as shown in Fig. 7. This joint also involves rotary motion, but the axis of rotation is parallel to the axes of the two links.

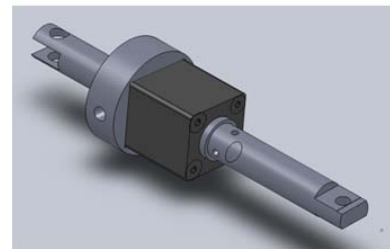

(a)



(b)

Fig. 7 (a) 3D CAD model and (b) the manufactured prototype of twisting (type T) joint

5. Revolving or type V joint as shown in Fig. 8. In this joint type, the axis of the input link is parallel to the axis of rotation of the joint, and the axis of the output link is perpendicular to the axis of rotation.

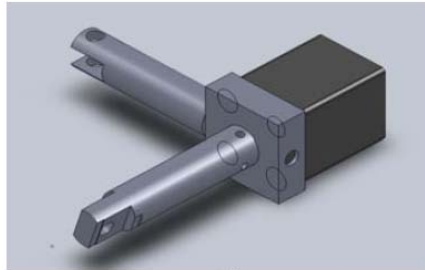

(a)



(b)

Fig. 8 (a) 3D CAD model and (b) the manufactured prototype of revolving (type V) joint

Given the five types of joints defined above, there are  $5 \times 5 \times 5 = 125$  different combinations of joints that can be used to design the robot assembly for a three-degree-of-freedom robot manipulator. Yet it is possible to use more than one of any particular joint in the robot that provides even a wider range of configurations. In addition, there are design variations within the individual joint types (e.g., physical size of the joint and range of motion). It is somewhat remarkable as there are only five basic configurations commonly available in commercial industrial robots as mentioned before [7]. Fig. 9 shows one of the many possible configurations of these joints. As can be seen in the figure, starting from the base link on the left, the joints used in the robot are respectively twisting, rotational, linear, rotational, and revolving that can be simply represented as TRLRV configuration. The work volume that can be achieved from the resultant configuration is quite complex that could suit some certain applications.

## VII. CONCLUSION

This paper presented the results of a research project on investigating possibility of designing modular joints to be assembled together in any desired order so that variety of robot configurations can be achieved. This would allow more flexibility for the work volume. This would trigger the design, and utilization of a new generation of industrial robots with a greater range of applications. Actuators have limited power so the range of possible configurations will be limited by this.

Also the large number of configurations available makes control of the system a very challenging task as kinematic and dynamic models are very complex.

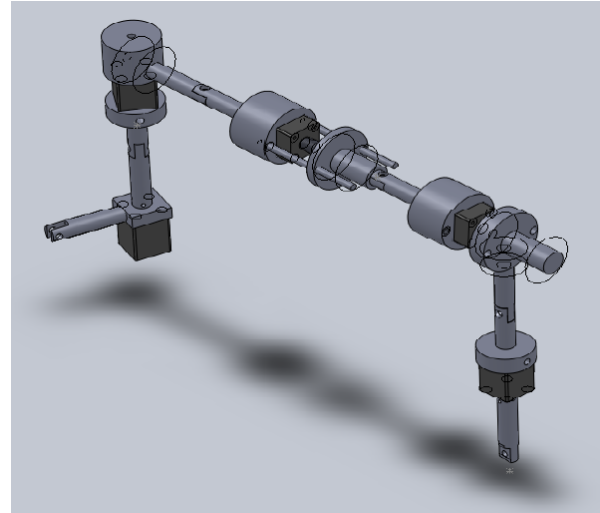

Fig. 9 TRLRV configuration resulted from assembling five joints

## ACKNOWLEDGMENT

Authors wish to thank Rushi Bhatt and Slavko Nikolic for their significant contributions throughout this work.

## REFERENCES

- [1] iRobotics. iRobot. Our History - About iRobot. [Online] <http://www.irobot.com/sp.cfm?pageid=203>
- [2] Manufacturing process of robots-enotes (study master)-@2011 enotes.com,inc.all rights reserved<http://www.enotes.com/how-products-encyclopedia/industrial-robot>
- [3] "Transformers" film directed Michael Bay, 2007, [http://en.wikipedia.org/wiki/Transformers\\_\(film\\_series\)](http://en.wikipedia.org/wiki/Transformers_(film_series))
- [4] L. Xuan; Z. Minglu; and L. Wei; "Methods to modular robot design," *Second International Symposium on Intelligent Information Technology Application*, Shanghai, China, 22-24 Dec. 2008, pp. 663 – 668.
- [5] A. S. Khusheef, G. Kothapalli, and M. Tolouei-Rad, "An approach for integration of industrial robot with vision system and simulation software," *Journal of the World Academy of Science Engineering and Technology*, 58 (2011) pp. 18-23.
- [6] M. P. Groover, et al., *Industrial robotics: technology, programming, and automation*, McGrawHill Book Company, NY, 1986.
- [7] M. P. Groover, *Automation, Production Systems, and Computer Integrated Manufacturing*, 3<sup>rd</sup> ed., Pearson Education Inc., New Jersey, 2008.
- [8] *The American Heritage Dictionary of English Language*, Houghton Mifflin Company, 2000. <http://www.bartleby.com/61/>.
- [9] K. Kedia, and D. Degand, "Modular robotic locomotion systems", Sunfest '99, On-line presentation, 1999.

**Majid Tolouei-Rad** is a senior lecturer at the School of Engineering, Edith Cowan University (ECU) in Perth, Western Australia.. His research interests include computer-integrated manufacturing, robotics and automation, and materials and manufacturing.

**Anurag Dhull** finished a Bachelors degree in mechanical engineering in 2011 from Edith Cowan University in Perth, Western Australia.