

Automatic Generation Control of an Interconnected Power System with Capacitive Energy Storage

Rajesh Joseph Abraham, D. Das and Amit Patra

Abstract—This paper is concerned with the application of small rating Capacitive Energy Storage units for the improvement of Automatic Generation Control of a multiunit multiarea power system. Generation Rate Constraints are also considered in the investigations. Integral Squared Error technique is used to obtain the optimal integral gain settings by minimizing a quadratic performance index. Simulation studies reveal that with CES units, the deviations in area frequencies and inter-area tie-power are considerably improved in terms of peak deviations and settling time as compared to that obtained without CES units.

Keywords—Automatic Generation Control, Capacitive Energy Storage, Integral Squared Error.

I. INTRODUCTION

ELECTRIC power generation and consumption should perfectly go hand-in-hand if an electric energy system is to be strictly maintained in its nominal state characterized by nominal frequency, voltage profile and load flow configuration. But because of the random nature of the power demands, this power generation-consumption equilibrium, in reality, cannot be strictly met. Thus, a power deviation occurs. This imbalance, causes a deviation of system frequency and tie-power from their scheduled values. To bring back the frequency and tie-power to their respective scheduled values, most of the utilities prefer to use integral or proportional-integral controllers in their system.

Different energy storage technologies such as pumped hydro, compressed air, fuel cells, batteries, Superconducting Magnetic Energy Storage (SMES), flywheels etc have been developed, investigated and explored to meet wide ranging needs. However, most of these technologies store electrical energy in other forms in addition to their own inherent disadvantages as pointed out by [1] – [2]. Capacitors can store electrical energy directly in their electric field by accumulating electrostatic charges on the two parallel plates. Reference [3] has shown that the relative merits of Capacitive

Energy Storage (CES) which outweigh Superconducting Magnetic Energy Storage (SMES), their magnetic counterparts are (1) CES at room temperatures or with cryogenic hypercapacitors (CHC) at 77 K eliminate the high operating costs of cryogenic refrigerators for liquid helium (4.2 K) in SMES. Hence, the effective energy efficiency is more and close to 100% for CES, the only losses being energy loss due to Joule heating in the electrodes and to internal leakage currents and self-discharge (2) CES has relatively higher energy density and smaller footprint and lower weight in contrast to SMES of the same storage capacity (3) CES can be upgraded by adding additional capacitor modules to increase capacity whereas an SMES coil cannot be so upgraded (4) There are no stray magnetic fields unlike in SMES. The electric fields within capacitors are entirely contained within the enclosure (5) There are no large forces in CES whereas; SMES coils develop strong internal Lorentz forces during discharge. These forces arise from the interactions between the currents and the magnetic field. But, the magnitude of forces from charge-field interactions in capacitors is smaller and force-related failures in capacitors are virtually unknown (6) SMES deliver high power rates but at the cost of high voltages. To withdraw energy from the circulating current, a voltage across the superconducting coil is generated by switching. For fast discharges and large power rates, very large voltages may be involved, which increases the risks of large voltage gradients within the coil and hence, turn-to-turn voltage breakdown. Capacitors are intrinsically "open circuits" to DC so that the only failure mode possible is a short circuit caused by voltage breakdown. When a CHC in a bank suffers a voltage failure, the current path is instantly burn out by the large momentary currents. This gives CES a self-protecting property that is absent in other energy storage systems. Hence, CHC energy storage systems are expected to be robust, have extremely low failure rates, and are fault tolerant. Further, no thermal shock failures have ever been observed for CES. Thus, their ruggedness for practical applications is assured. (7) CES involves lower initial costs. Preliminary estimates indicate that equivalent energy storage in a CES involves an initial cost 40-50% less than that for SMES. In light of this, Capacitive Energy Storage (CES) systems may be an alternative for improving the performance of interconnected power system and either supercapacitors or

Rajesh Joseph Abraham is Assistant Professor with the Department of Avionics, Indian Institute of Space Science & Technology, Thiruvananthapuram 695022, Kerala, India (e-mail: rajeshja@gmail.com).

D. Das and Amit Patra are Professors with the Department of Electrical Engineering, Indian Institute of Technology, Kharagpur 721302, West Bengal, India.

CHC can be used for storage purposes in CES.

The AGC with a CES unit, has been studied in [4] but, that of a standalone power system.

In view of the above, the main objectives of the present work are:

- (1) To study the effect of CES units on AGC of multiunit multiarea power system considering GRC
- (2) To find out a suitable error signal to the CES control logic.
- (3) To optimize the integral gain settings using Integral Square Error (ISE) technique by minimizing a quadratic performance index without and with CES units in the presence of GRCs.
- (4) To compare the dynamic responses without and with CES units.

II. SYSTEM INVESTIGATED

Since the system under consideration is exposed to a small change in load during its normal operation, a linearized model is sufficient for its dynamic representation. Fig. 1 shows the small perturbation transfer function block diagram model of the two-area power system.

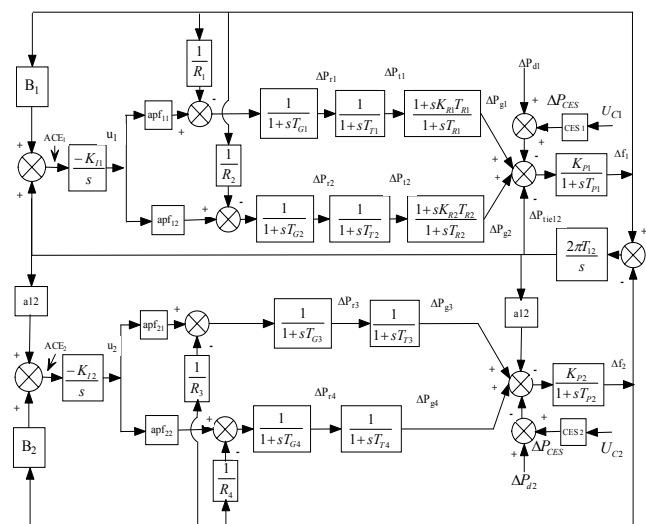

Fig. 1 The two-area interconnected power system model with CES units

The nominal parameters of the power system as well as the CES units are given in the Appendix. Area 1 consists of two reheat units and area 2 consists of two non-reheat units. Because of the thermodynamic and mechanical constraints, there is a limit to the rate at which the output power of steam turbines can be changed. This limit is referred to as Generator Rate Constraint (GRC). For the present study, a GRC of 3% per min. for reheat units and 10% per min. for nonreheat units have been considered for each unit in areas 1 and 2 respectively as in [5]. apf_{11} and apf_{12} are the ACE participation factors in area 1 and apf_{21} and apf_{22} are the ACE participation factors in area 2. Note that $apf_{11} + apf_{12} = 1.0$ and $apf_{21} + apf_{22} = 1.0$. A small rating CES unit of 3.8 MJ storage capacity is fitted to both the areas 1 and 2 to examine its effect

on the power system performance. A step load disturbance of 1% of nominal loading has been considered for the investigation. The control signal to the CES unit can be frequency deviation or the Area Control Error (ACE). In this paper, both the cases are studied.

Since the power system model considered is a linear continuous-time dynamic system, it can be represented by the standard state space model as:

$$\dot{X} = AX + BU + \Gamma p \quad (1)$$

where X, U and p are the state, control and disturbance vectors respectively and A, B and Γ are constant matrices of compatible dimensions associated with them. For the system considered, the state, control and disturbance vectors are respectively given as

$$X^T = [\Delta f_1 \ \Delta f_2 \ \Delta P_{tie12} \ \Delta P_{g1} \ \Delta P_{g2} \ \Delta P_{g3} \ \Delta P_{g4} \ \Delta P_{t1} \ \Delta P_{t2} \ \Delta P_{r1} \ \Delta P_{r2} \ \Delta P_{r3} \ \Delta P_{r4} \ \Delta E_{d1} \ \Delta E_{d2} \ \Delta I_{d1} \ \Delta I_{d2}]$$

$$U^T = [U_1 \ U_2] \text{ and } p^T = [\Delta P_{d1} \ \Delta P_{d2}]$$

III. CAPACITIVE ENERGY STORAGE

A Capacitive Energy Storage (CES) consists of, from circuit point of view, a supercapacitor or a cryogenic hypercapacitor (CHC), a Power Conversion System (PCS) and the associated protective circuitry as shown in Fig. 2. CHCs differ from the

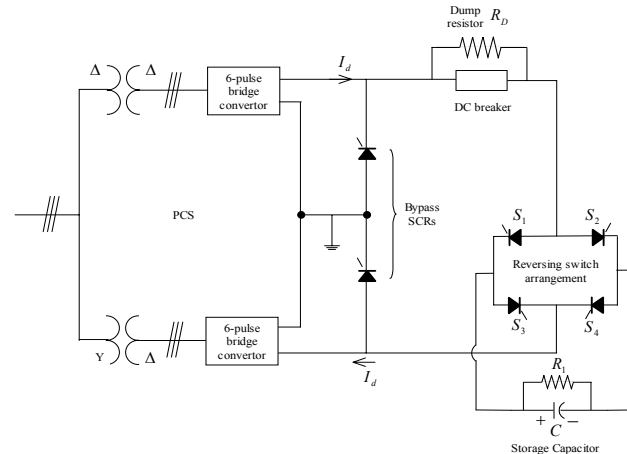

Fig. 2 Capacitive Energy Storage Unit

conventional capacitors in that they are multilayer ceramic capacitors with a dielectric that has its peak dielectric constant at 77 K, the temperature of liquid nitrogen. The dimensions of the capacitor are determined by the energy storage capacity required. The storage capacitor C may consist of many discrete capacitance units connected in parallel. The resistor R_1 connected in parallel across the capacitor is the lumped equivalent resistance representing the dielectric and leakage losses of the capacitor bank. The PCS, consisting of an ac-to-dc rectifier and a dc-to-ac inverter, form the electrical interface between the capacitor and the power system. Two bridges are preferred so that harmonics produced on the ac bus and in the output voltage to the capacitor are reduced. The bypass thyristors provide a path for current I_d in the event of a

converter failure. The dc breaker allows current I_d to be diverted into the energy dump resistor R_D if the converter fails. Assuming the losses to be negligible, the bridge voltage E_d is given by [6]

$$E_d = 2E_{d0}\cos\alpha - 2I_dR_D \quad (2)$$

By changing the relative phase angle α of this pulse through a range from 0° to 180° , the voltage across the capacitor, E_d can be made to vary from its maximum positive value to the maximum negative value.

The voltage pulses from the firing circuits are timed to cause each SCR to begin conduction at a prescribed time. The sequence maintains a constant average voltage across the capacitor. The exact timing of the firing pulses relative to the phase of 50 Hz ac voltage determines the average dc voltage across the capacitor. Since the bridges always maintain unidirectional current and E_d is uniquely defined by α for positive and negative values, the power flow P_d in the capacitor is uniquely determined by α in both magnitude and direction. Thus, without any switching operation, reversibility as well as magnitude control of the power flow is achieved by continuously controlling the firing angle α . The firing angle of the converter is controlled by an algorithm determined by utility needs, but basically the control circuit responds to a demand signal for a certain power level, either positive or negative. Then based on the voltage across the capacitor, a firing angle is calculated and transmitted to the firing circuit. The response time of the control and firing circuits to a new demand signal are so short that a new firing angle may be chosen for the very next SCR to be pulsed, say within a few milliseconds. This rapid response to power demands that may vary by hundreds of megawatts is a unique capability of CES relative to other energy storage systems such as pumped hydro, compressed air, flywheels etc. This ability to respond quickly allows the CES unit to function not only as an energy storage unit but also as a spinning reserve and to provide stability in case of disturbances on the utility system. The reversing switch arrangement provided accommodates the change of direction of the current in the capacitor during charging (rated load period) and discharging (during peak load period), since the direction of the current through the bridge converter (rectifier/inverter) cannot change. During the charging mode, switches S_1 and S_4 are on and S_2 and S_3 are off. In the discharging mode, S_2 and S_3 are on and S_1 and S_4 are off.

The normal operating point of the capacitor can be such that the maximum allowable energy absorption equals the maximum allowable energy discharge. This will make the CES unit very effective in damping the oscillations created by sudden increase or decrease in load. If E_{d0} denotes the set value of voltage and E_{dmax} and E_{dmin} denote the maximum and minimum limits of voltage respectively, then,

$$\frac{1}{2}CE_{dmax}^2 - \frac{1}{2}CE_{d0}^2 = \frac{1}{2}CE_{d0}^2 - \frac{1}{2}CE_{dmin}^2 \quad (3)$$

and hence,

$$E_{d0} = \frac{[E_{dmax}^2 + E_{dmin}^2]^{1/2}}{2} \quad (4)$$

The capacitor voltage should not be allowed to deviate beyond certain lower and upper limits. During a sudden system disturbance, if the capacitor voltage goes too low and if another disturbance occurs before the voltage returns to its normal value, more energy will be withdrawn from the capacitor which may cause discontinuous control. To overcome this problem, a lower limit is imposed for the capacitor voltage and in the present study, it is taken as 30% of the rated value.

Initially, the capacitor is charged to its set value of voltage E_{d0} (less than the full charge value) from the utility grid during its normal operation. To charge the capacitor at the maximum rate, E_d is set at its maximum value by setting $\alpha = 0^\circ$. At any time during the charging period, the stored energy in Joules is proportional to the square of the voltage as described by

Once the voltage reaches its rated value, it is kept floating at this value by a continuous supply from PCS, sufficient to overcome the resistive drop. Since this E_{d0} is very small, the firing angle α will be nearly 90° . The CES is now ready to be put into service. When there is a sudden rise in load demand, the stored energy is almost immediately released through the PCS to the grid as pulsed AC. As the governor and other control mechanisms start working to set the power system to the new equilibrium condition, the capacitor charges to its initial value of voltage E_{d0} . The action during sudden releases of load is similar. The capacitor immediately gets charged towards its full value, thus absorbing some portion of the excess energy in the system, and as the system returns to its steady state, the excess energy absorbed is released and the capacitor voltage attains its normal value.

The power flow into the capacitor at any instant is $P_d = E_d \cdot I_d$ and the initial power flow into the capacitor is $P_{d0} = E_{d0} \cdot I_{d0}$ where E_{d0} and I_{d0} are the magnitudes of voltage and current prior to the load disturbance. When a load disturbance occurs, the power flow into the coil is

$$P_{d0} + \Delta P_d = (E_{d0} + \Delta E_d)(I_{d0} + \Delta I_d) \quad (5)$$

so that the incremental power change in the capacitor is

$$\Delta P_d = (I_{d0}\Delta E_d + \Delta E_d\Delta I_d) \quad (6)$$

The term $E_{d0} \cdot I_{d0}$ is neglected since $E_{d0} = 0$ in the storage mode to hold the rated voltage at constant value.

IV. CES BLOCK DIAGRAM REPRESENTATION

The set value of the CES voltage has to be restored at the earliest, after a load disturbance so that the CES unit is ready to act for the next load disturbance. For this, the capacitor voltage deviation can be sensed and used as a negative feedback signal in the CES control loop so that fast restoration of the voltage is achieved as shown in Fig. 3.

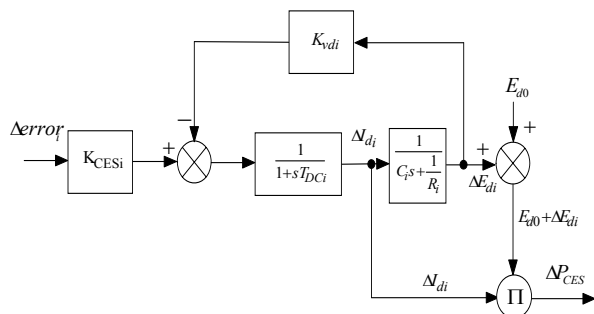

Fig. 3 CES block diagram with capacitor voltage deviation feedback

V. CES CONTROL LOGIC

Either frequency deviation or Area Control Error (ACE) can be used as the control signal to the CES unit ($\Delta error_i = \Delta f_i$ or ACE_i). E_{di} is then continuously controlled in accordance with this control signal. For the i th area, if the frequency deviation Δf_i (i.e., $\Delta error_i = \Delta f_i$) of the power system is used as the control signal to CES, then the deviation in the current, ΔI_{di} is given by

$$\Delta I_{di} = \left[\frac{1}{1+sT_{DCi}} \right] \left[K_{CESi} \Delta f_i - K_{vdi} \Delta E_{di} \right] \quad (7)$$

If the tie-line power flow deviations can be sensed, then the Area Control Error (ACE) can be fed to the CES as the control signal (i.e., $\Delta error_i = ACE_i$). Being a function of tie-line power deviations, ACE as the control signal to CES, may further improve the tie-power oscillations. Thus, ACE of the two areas are given by

$$ACE_i = B_i \Delta f_i + \Delta P_{tieij}; i, j = 1, 2$$

where ΔP_{tieij} is the change in tie-line power flow out of area i to j . Thus, if ACE_i is the control signal to the CES, then the deviation in the current ΔI_{di} would be

$$\Delta I_{di} = \left[\frac{1}{1+sT_{DCi}} \right] \left[K_{CESi} \Delta ACE_i - K_{vdi} \Delta E_{di} \right]; i, j = 1, 2 \quad (8)$$

VI. OPTIMISATION OF INTEGRAL CONTROLLER

Integral Squared Error (ISE) technique is used for obtaining the optimum gain settings of the integral controllers. A quadratic performance index

$$J = \int_0^t (\Delta f_1^2 + \Delta f_2^2 + \Delta P_{tie12}^2) dt$$

is minimised for 1% step load disturbance in either of the areas for obtaining the optimum values of integral gain settings. It is proposed in [7] that, if the types of units are different in each area, then, the optimum gain settings can be obtained on an individual basis by considering the other area

uncontrolled. In the present work, the optimum values of integral gain settings of the two-area interconnected power system is also obtained by keeping the other area uncontrolled. For different combinations of ACE participation factors, the optimal integral gains obtained using ISE technique by minimising the above quadratic performance index without and with CES units in the presence of GRCs, have been tabulated as shown in Tables 1 and 2 for areas 1 and 2 respectively.

TABLE I
OPTIMAL INTEGRAL GAIN SETTINGS FOR AREA 1

apf ₁₁	apf ₁₂	Without CES units	With CES units	
			Frequency Deviation	Area Control Error
0.10	0.90	0.0640	0.0880	1.5000
0.25	0.75	0.0820	0.0932	0.8360
0.50	0.50	0.0930	0.1600	0.5210
0.75	0.25	0.0820	0.0932	0.8360
0.90	0.10	0.0640	0.0880	1.5000

TABLE II
OPTIMAL INTEGRAL GAIN SETTINGS FOR AREA 2

apf ₂₁	apf ₂₂	Without CES units	With CES units	
			Frequency Deviation	Area Control Error
0.10	0.90	0.0960	0.2190	0.1630
0.25	0.75	0.1170	0.2230	0.1800
0.50	0.50	0.1020	0.2210	0.1760
0.75	0.25	0.1170	0.2230	0.1800
0.90	0.10	0.0640	0.2190	0.1630

VII. SIMULATION RESULTS

The responses of the two-area interconnected system have been studied in detail. Fig. 4 shows the dynamic responses for frequency and tie-line power deviations and Fig. 5 shows the generation responses for 1% step load disturbance in area 1 considering $apf_{11} = apf_{12} = 0.5$ and $apf_{21} = apf_{22} = 0.5$ without CES units and with CES units having Δf_i as well as ACE_i as the control logic signals. From Figs. 4 and 5, it is evident that the dynamic responses have improved significantly with the use of CES units. It can be observed that with the use of Δf_i feedback to the CES control logic, the dynamic responses are better than those obtained with ACE_i feedback and far improved than that without CES units.

As the load disturbance has occurred in area 1, at steady state, the power generated by generating units in area 1 are in proportion to the ACE participation factors. Therefore, as in Fig. 5, at steady state, $\Delta P_{g1ss} = \Delta P_{d1} \times apf_{11} = 0.01 \times 0.5 = 0.005$ p.u. MW and $\Delta P_{g2ss} = \Delta P_{d2} \times apf_{12} = 0.01 \times 0.5 = 0.005$ p.u. MW. Similarly, $\Delta P_{g3ss} = \Delta P_{d2} \times apf_{21} = 0 \times 0.5 = 0$ p.u. MW and $\Delta P_{g4ss} = \Delta P_{d2} \times apf_{21} = 0 \times 0.5 = 0$ p.u. MW at steady state.

Similar findings are also observed for 1% step load disturbance in area 2 as in Figs. 6 and 7.

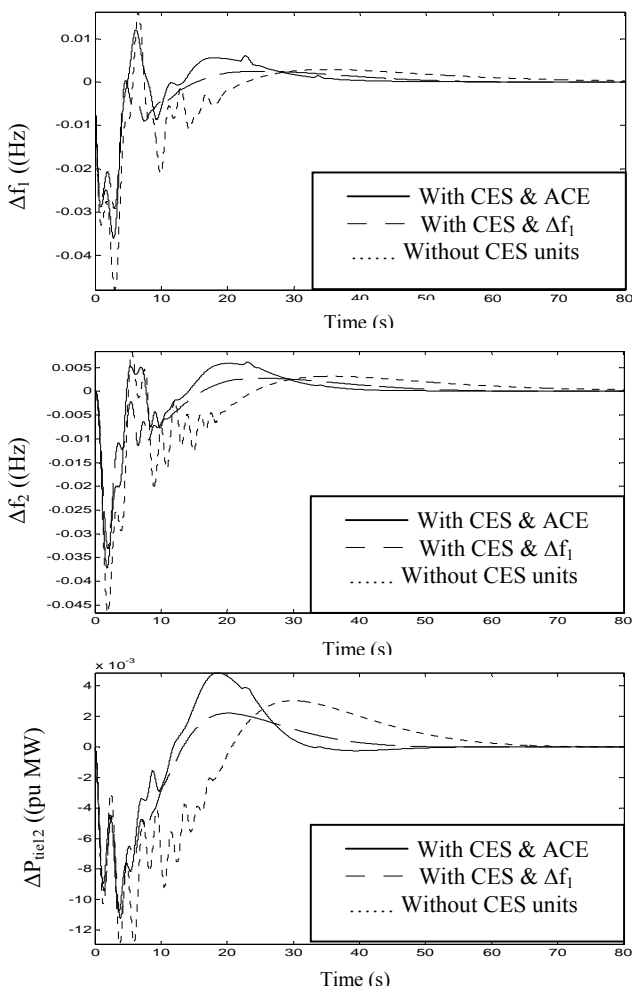

Fig. 4 Dynamic responses for Δf_1 , Δf_2 and ΔP_{tie12} considering a step load disturbance of 0.01 pu in area-1.

VIII. CONCLUSIONS

In this paper, the responses of a two-area interconnected thermal power system with reheat and non reheat units have been studied considering generation rate constraints and integral gain settings have been optimized by Integral Squared Error (ISE) technique. The optimal integral gain settings with CES units are found to be higher than those without CES units. Small rating Capacitive Energy Storage units are fitted to both the areas and responses show that they are capable of consuming the oscillations in area frequency deviations and tie-line power deviations of the power system. Further, CES units reduce the settling time of the responses. Two different control logic for CES units are attempted and it was found that, the dynamic responses with frequency feedback to CES are better than that obtained with ACE feedback to CES units and far superior than that without CES units. Hence, it may be concluded that CES units are efficient and effective for improving the dynamic performance of AGC of interconnected power systems.

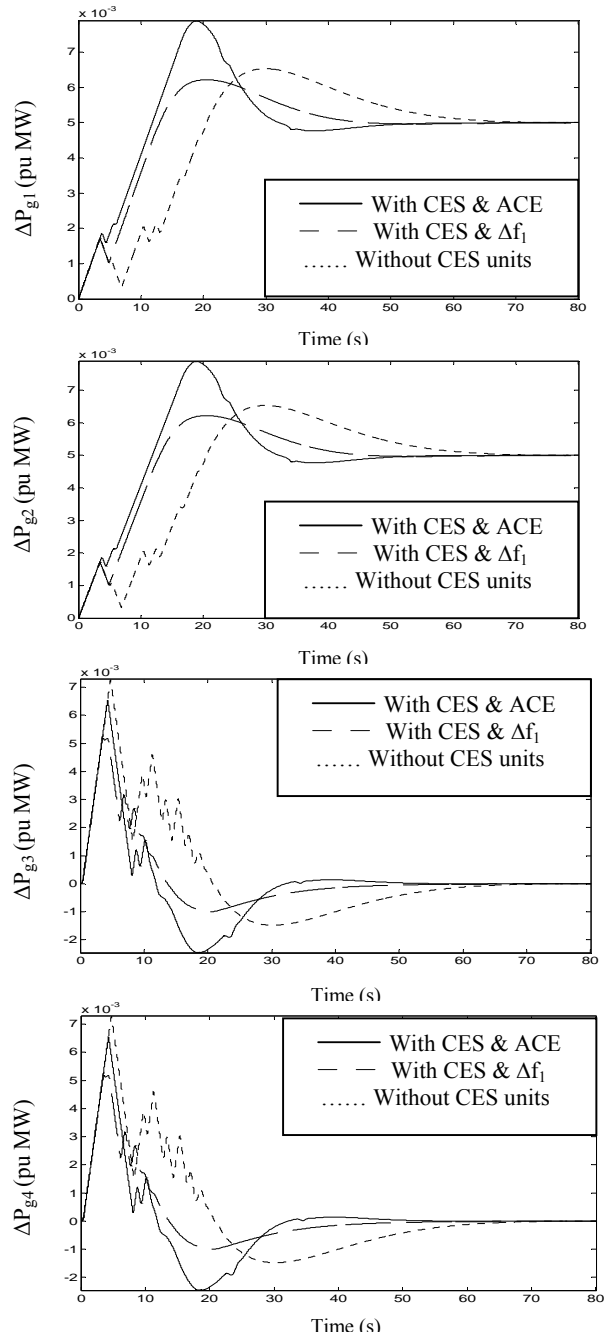

Fig. 5 Dynamic responses for ΔP_{g1} , ΔP_{g2} , ΔP_{g3} and ΔP_{g4} considering a step load disturbance of 0.01 pu in area-1.

APPENDIX

(A) Capacitive Energy Storage Data

$K_{vd} = 0.1$ kV/kA, $K_O = 70$ kV/Hz, $T_{DC} = 0.05$ s, $C = 1$ F, $R = 100\Omega$, $E_{d0} = 2$ kV

(B) System Data

$P_{R1} = P_{R2} = 1200$ MW, $T_{P1} = T_{P2} = 20$ s
 $K_{P1} = K_{P2} = 120$ Hz/p.u. MW, $T_{R1} = T_{R2} = 10$ s,
 $K_{R1} = K_{R2} = 0.5$, $T_{T1} = T_{T2} = T_{T3} = T_{T4} = 0.3$ s
 $T_{G1} = T_{G2} = T_{G3} = T_{G4} = 0.08$ s

$R_1 = R_2 = R_3 = R_4 = 2.4 \text{ Hz/p.u. MW}$
 $T_{12} = 0.0866 \text{ p.u. MW/rad.}, \Delta P_{D1} = 0.01 \text{ p.u.}$
 $D_1 = D_2 = 8.333 \times 10^{-3} \text{ p.u. MW/Hz}$
 $B_1 = B_2 = 0.4249 \text{ p.u. MW/Hz}, \Delta P_{D2} = 0 \text{ p.u.}$

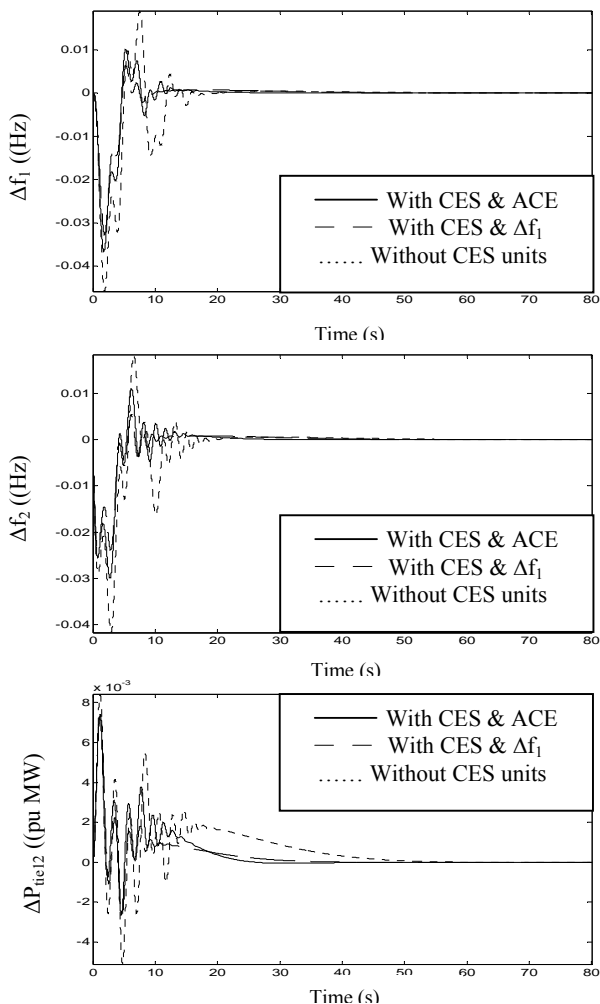

Fig. 6 Dynamic responses for Δf_1 , Δf_2 and ΔP_{tie12} considering a step load disturbance of 0.01 pu in area-2.

ACKNOWLEDGMENT

Rajesh Joseph Abraham acknowledges with gratitude, the financial grant from the All India Council for Technical Education (A.I.C.T.E), New Delhi, India in the form of National Doctoral Fellowship (NDF 2003) with which this work was carried out.

REFERENCES

- [1] Al Pivec, B.M. Radimer and E.A. Hyman, "Utility Operation of Battery Energy Storage at the BEST facility," *IEEE Transactions on Energy Conversion*, vol. EC-1, 1986, pp. 47-54
- [2] J.D. Boyes and N.H. Clark, "Technologies for Energy Storage Flywheels and Superconducting Magnetic Energy Storage," in *Proc. Power Engineering Society Summer Meeting*, 2000, pp. 1548-1550
- [3] E. Schempp and W.D. Jackson, "Systems Considerations in Capacitive Energy Storage," *Proc. IEEE Conf. on Energy Conversion Engg*, 1996

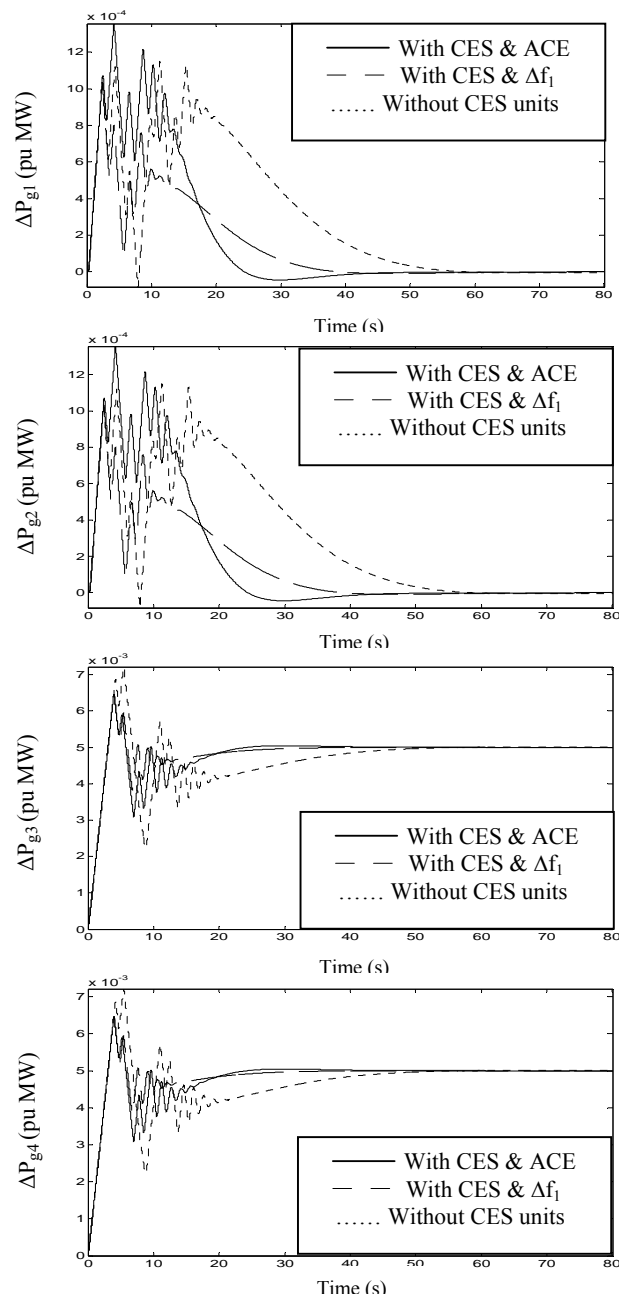

Fig. 7 Dynamic responses for ΔP_{g1} , ΔP_{g2} , ΔP_{g3} and ΔP_{g4} considering a step load disturbance of 0.01 pu in area-2.

- [4] T. Hiyama, D. Zuo and T. Funabashi, "Automatic Generation Control of stand alone power system with energy capacitor system," *IEE Conf. on Power System Management and Control*, 2002, pp. 59-64.
- [5] R.J. Abraham, "Automatic Generation Control in Traditional and Deregulated Environments," Ph.D dissertation, Dept. Elect. Eng., Indian Institute of Technology, Kharagpur, 2007
- [6] R.J. Abraham, D. Das and A. Patra, "Effect of Capacitive Energy Storage on Automatic Generation Control," *Proc. 7th International Power Engineering Conference*, Singapore, 2005, pp. 1070-1074.
- [7] M.L. Kothari P.S. Satsangi and J. Nanda, "Automatic generation control of an interconnected hydrothermal system in continuous and discrete mode considering generation rate constraints," *Proc. IEE*, vol. 130, 1983, pp. 17-21.